

Deutsches Institut für Bautechnik

Anstalt des öffentlichen Rechts

Kolonnenstr. 30 L
10829 Berlin
Germany

Tel.: +49(0)30 787 30 0
Fax: +49(0)30 787 30 320
E-mail: dibt@dibt.de
Internet: www.dibt.de

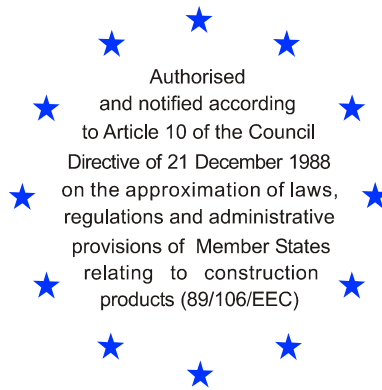

DIBt

Mitglied der EOTA
Member of EOTA

European Technical Approval ETA-10/0165

English translation prepared by DIBt - Original version in German language

Handelsbezeichnung <i>Trade name</i>	SikaTank FB-25
Zulassungsinhaber <i>Holder of approval</i>	Sika Deutschland GmbH Kornwestheimer Straße 103-107 70439 Stuttgart DEUTSCHLAND
Zulassungsgegenstand und Verwendungszweck <i>Generic type and use of construction product</i>	Sika Fugenbandsystem Sika Tank FB-25 zur Verwendung in Anlagen zum Lagern, Abfüllen und Umschlagen flüssiger Chemikalien (wassergefährdende Stoffe) <i>Sika sealing band system SikaTank FB-25 used in facilities for the storage, handling and filling of liquid chemicals (substances hazardous to water)</i>
Geltungsdauer: <i>Validity:</i>	vom <i>from</i> 19 April 2010 bis <i>to</i> 14 October 2013
Herstellwerk <i>Manufacturing plant</i>	Sika Deutschland GmbH Werk Nr.: DE 18

Diese Zulassung umfasst
This Approval contains

22 Seiten einschließlich 7 Anhänge
22 pages including 7 annexes



Europäische Organisation für Technische Zulassungen
European Organisation for Technical Approvals

I LEGAL BASES AND GENERAL CONDITIONS

- 1 This European technical approval is issued by Deutsches Institut für Bautechnik in accordance with:
 - Council Directive 89/106/EEC of 21 December 1988 on the approximation of laws, regulations and administrative provisions of Member States relating to construction products¹, modified by Council Directive 93/68/EEC² and Regulation (EC) N° 1882/2003 of the European Parliament and of the Council³;
 - Gesetz über das In-Verkehr-Bringen von und den freien Warenverkehr mit Bauprodukten zur Umsetzung der Richtlinie 89/106/EWG des Rates vom 21. Dezember 1988 zur Angleichung der Rechts- und Verwaltungsvorschriften der Mitgliedstaaten über Bauprodukte und anderer Rechtsakte der Europäischen Gemeinschaften (Bauproduktengesetz - BauPG) vom 28. April 1998⁴, as amended by law of 31 October 2006⁵;
 - Common Procedural Rules for Requesting, Preparing and the Granting of European technical approvals set out in the Annex to Commission Decision 94/23/EC⁶.
- 2 Deutsches Institut für Bautechnik is authorized to check whether the provisions of this European technical approval are met. Checking may take place in the manufacturing plant. Nevertheless, the responsibility for the conformity of the products to the European technical approval and for their fitness for the intended use remains with the holder of the European technical approval.
- 3 This European technical approval is not to be transferred to manufacturers or agents of manufacturers other than those indicated on page 1, or manufacturing plants other than those indicated on page 1 of this European technical approval.
- 4 This European technical approval may be withdrawn by Deutsches Institut für Bautechnik, in particular pursuant to information by the Commission according to Article 5(1) of Council Directive 89/106/EEC.
- 5 Reproduction of this European technical approval including transmission by electronic means shall be in full. However, partial reproduction can be made with the written consent of Deutsches Institut für Bautechnik. In this case partial reproduction has to be designated as such. Texts and drawings of advertising brochures shall not contradict or misuse the European technical approval.
- 6 The European technical approval is issued by the approval body in its official language. This version corresponds fully to the version circulated within EOTA. Translations into other languages have to be designated as such.

1 Official Journal of the European Communities L 40, 11 February 1989, p. 12

2 Official Journal of the European Communities L 220, 30 August 1993, p. 1

3 Official Journal of the European Union L 284, 31 October 2003, p. 25

4 *Bundesgesetzblatt Teil I 1998*, p. 812

5 *Bundesgesetzblatt Teil I 2006*, p.2407, 2416

6 Official Journal of the European Communities L 17, 20 January 1994, p. 34

II SPECIFIC CONDITIONS OF THE EUROPEAN TECHNICAL APPROVAL

1 Definition of the product and intended use

1.1 Definition of the construction product

(1) The "Sika sealing band system Sika Tank FB-25" by Sika Deutschland GmbH (in the following called "sealing system"), is made of:

- Primers, "SikaTank Primer PK-3", "SikaTank Primer PK-3S" and "SikaTank Primer PK-2"
- Adhesive membrane "SikaTank PK 25-ST"
- Joint band "SikaTank FB-25" and
- where necessary backfill material.

(2) The following primers are given by the manufacturer of the sealing system especially for the respective contact material.

- "SikaTank Primer PK-3": For sealing constructions made of concrete (pre-fabricated elements or in-situ concrete) and for parts of sealing constructions made of coated cast-steel (only permissible with corrosion protection based on alkyd resin, e.g. "Zinkphosphat-Rost- und Haftprimer" of the company A. Harbsmeyer KG,
- "SikaTank Primer PK-3S": For sealing constructions made of asphalt and semi-rigid pavements and
- "SikaTank Primer PK-2": For sealing constructions made of polymer-concrete based on UP-resin and for parts of sealing constructions made of uncoated cast steel

(3) A closed-cell backfill material, compatible with the joint band and the adhesive membrane, is used.

(4) The sealing system is glued with the adhesive membrane on the prepared construction, made of different materials (contact material), after preparation of the surface with the respective primer.

(5) The sealing system is applied with a defined ratio between its thickness "d" and width "b". Evidence of suitability of the respective joint geometry is provided within the scope of the approval tests.

1.2 Intended use

(1) The sealing system is intended for use in liquid proof installations (e.g. made of concrete) for the dealing of certain liquid chemicals (substances hazardous to water) both inside of buildings as well as in the open.

(2) It shall be used for sealing of vertical and horizontal movement joints, which shall allow unrestrained deformation of structural elements (e.g. shrinkage, temperature-dependent alterations in length or the effects of different ground deformations) and, with regard to their sealing function, shall not be adversely affected.

(3) The sealing system shall be used under constantly changing mechanical actions in liquid proof installations.

(4) It is to be installed at normal environmental, structural element and material temperatures (usually within a range of +5 °C to +40 °C). It is intended to be used usually at temperatures between -20 °C and +70 °C (unless it is tested at a different range of temperatures), without being adversely affected with regard to their sealing function. The temperature of the liquid chemicals (substances hazardous to water) during the contact with the joint sealing system shall be not higher than 30 °C.

(5) The joint sealing system shall be used in liquid-proof constructions made of e.g. concrete dealing with liquid chemicals (substances hazardous to water), which are exposed to the simultaneous or succeeding effects of combinations (e.g. chemicals, deformation movements, temperature, weather).

(6) The sealing system shall be used for the repair of joints and cracks.

(7) The provisions made in this European technical approval are based on an assumed working life of the "Sika sealing band system Sika Tank FB-25" of 10 years, provided that the conditions for the transport/storage/installation/use/servicing/correction of the defect/utilization are met.

The indications given on the working life cannot be interpreted as a guarantee given by the producer, but are to be regarded only as a means for choosing the right products in relation to the expected economically reasonable working life of the works.

2 Characteristics of product and methods of verification

2.1 General

(1) The sealing system shall correspond to the drawings and the details of the annexes of this approval.

(2) The chemical composition or the formula of the joint band, the adhesive membrane and of the respective primer shall correspond to the information deposited with Deutsches Institut für Bautechnik.

(3) The characteristics of the material, the dimensions and tolerances which are not declared in this approval shall correspond to the information laid down in the technical documentation⁷ of this European technical approval.

2.2 Characteristics

(1) The sealing system

- is resistant and impermeable to the liquids listed in Annex 2 for the stress level S_1 , H_1 , F_1 "low" and S_2 , H_2 and F_2 "medium" (definition of stress levels see Annex 7),
- is resistant to aging, hydrolysis and weather,
- is suitable to be directly applied onto joint sealing systems on polysulfide basis that has already hardened,
- is suitable to be attached to certain permissible contact materials (see Annex 4, Table 1),
- is suitable to take up the extension-, compression and shear deformations documented in Annex 3, Table 2 in the area of parallel joint side walls as well as Tee and cross intersections without becoming leaky,
- is accessible for pedestrians only according to the level of road serviceability (see Annex 3, Table 2),
- meets the requirements of the reaction-to-fire class "E" in accordance with EN 13501-1⁸ (see Annex 3, Table 2),
- under consideration of the determinations of Annex 5, Figure 2 prevents migration of the liquids listed in Annex 2 in the area of the joint and
- meets the requirements of the slipping behaviour of vertical glued joint bands in the installed state stressed with temperature up to 200 °C.

⁷ The technical documentation of this European technical approval is deposited with Deutsches Institut für Bautechnik and shall be made available to the approved bodies, who are involved in the procedure of conformity attestation, for the fulfilment of their tasks.

⁸ EN 13501-1: Fire classification of construction products and building elements

2.3 Composition

(1) The sealing system is made of the joint band, primers, the adhesive membrane and a suitable backfill material -if necessary.

– Joint band

"Sika Tank FB-25":

The joint band is made of the extruded joint sealing compound "SikaTank PK 25-ST". The compound is identical with the compound according to ETA-10/0151. The joint band is based on polysulfide.

– Primers

- "Sika Tank Primer PK-3":

"Component A" and "Component B" are components based on epoxy resin;

- "Sika Tank Primer PK-3S":

"Component A" and "Component B" are components based on epoxy resin;

- "Sika Tank Primer PK-2":

1-Component Primer based on silane.

These primers are identical with the primers according to ETA-10/0151.

– Adhesive membrane

"SikaTank PK 25-ST":

The adhesive membrane is identical with the joint sealing compound according to ETA-10/0151. It is based on polysulfide.

– Backfill material

A closed-cell backfill material, compatible with the sealing system, is to be chosen and to be used in accordance with ETA-10/0151 and the provisions by the manufacturer. The used backfill material has at least to meet the requirements for building products of reaction-to-fire class E in accordance with EN 13501-1

(2) More information about the individual components of the sealing system are given in Annex 4.

2.4 Emission of dangerous substances

(1) According to the manufacturer's declaration the components of the joint sealing system taking account of the EU database⁹ does not contain any dangerous substances.

(2) Within the scope of this approval there may be other requirements applicable to dangerous substances resulting from transposed European legislation or applicable national regulations and administrative provisions. These requirements need also to be complied with.

(3) There may be other requirements applicable to the products resulting from other applicable national regulations and administrative provisions. These requirements need also to be complied with.

⁹ References in Guidance Paper H: A harmonised approach with regard to the handling of dangerous substances according to the Construction Products Directive, Brussels 18 February 2000

3 Evaluation and attestation of conformity and CE marking

3.1 General

The evaluation and the attestation of conformity of the sealing system with the provisions of this European technical approval is performed for each factory on the basis of the provisions of section 3.2 related to the respective system of attestation of conformity (e.g. system 2+: initial type-testing by the manufacturer and a factory production control).

3.2 System of attestation of conformity

(1) According to the Decision 2003/656/EC of the European Commission¹⁰ system 2+ of the attestation of conformity is to be used in reference to hygiene, health and the environment (ER 3) and general aspects of the sealing system.

(2) Additionally according to the Decision 2001/596/EC of the European Commission¹¹ the System 1 of attestation of conformity has to be taken into account in relation to the reaction-to-fire performance. These systems of attestation of conformity are described in the following:

(3) System 2+

Declaration of conformity by the manufacturer with reference to ER 3 and general aspects for the mastic asphalt mixture on the basis of:

(a) Tasks for the manufacturer:

- (1) initial type-testing of the product;
- (2) factory production control;
- (3) testing of samples taken at the factory in accordance with a control plan.

(b) Tasks for the approved body:

Inspection body:

- (4) Initial inspection of the factory and of factory production control,
- (5) continuous surveillance, assessment and approval of factory production control

Certification body:

- (6) Certification of conformity of the product

(4) System 1

Declaration of conformity by the manufacturer with reference to the reaction-to-fire performance of the mastic asphalt mixture on the basis of:

(a) Tasks for the manufacturer:

- (1) factory production control;
- (2) further testing of samples taken at the factory in accordance with a prescribed test plan

(b) Tasks for the approved bodies:

Testing laboratory:

- (3) Initial type-testing
- (4) Audit-testing of samples taken at the factory, on the open market or on the construction side

¹⁰ Letter of the European Commission to EOTA of 15.10.2004.

¹¹ Official Journal of the European Communities L 209/33 of 2.8.2001.

Inspection body:

- (5) Initial inspection of factory and of factory production control,
- (6) continuous surveillance, assessment and approval of factory production control

Certification body:

- (7) Certification of the conformity of the product

Note: Approved bodies are also named "notified bodies"

3.3 Responsibilities

3.3.1 Tasks for the manufacturer

3.3.1.1 Factory production control

(1) The manufacturer shall exercise permanent internal control of production. All the elements, requirements and provisions adopted by the manufacturer shall be documented in a systematic manner in the form of written policies and procedures, including records of results performed. This production control system shall insure that the product is in conformity with this European technical approval.

(2) The manufacturer may only use raw materials stated in the technical documentation of this European technical approval.

(3) The factory production control shall be in accordance with the control plan of April 2010 relating to the European technical approval ETA-10/0165 issued on 19.04.2010 which is part of the technical documentation of this European technical approval. The control plan is laid down in the context of the factory production control system operated by the manufacturer and deposited with Deutsches Institut für Bautechnik.¹²

(4) The results of factory production control shall be recorded and evaluated in accordance with the provisions of the control plan. The records shall include at least the following information:

- Designation of the product, of the initial materials,
- type of inspection or test,
- date of the manufacture of the product, batch N° (if relevant) and date of the inspection or test of the product / the initial materials,
- results of the inspections or tests and, if applicable, comparison with the requirements and
- signature of the person responsible for the factory production control.

(5) The records shall be kept for at least (a minimum of) five years. On request they shall be presented to Deutsches Institut für Bautechnik.

(6) Details concerning extent, type and frequency of the tests or inspections to be performed within the scope of the factory production control shall correspond to the control plan which is part of the technical documentation to this ETA.

3.3.1.2 Other tasks for the manufacturer

(1) The manufacturer shall, on the basis of a contract, involve a body which is approved for the tasks referred to in section 3.2 in the field of joint band systems in order to undertake the actions lay down in section 3.2.2. For this purpose, the "control plan" part 2 referred to in sections 3.2.1.1 and 3.2.2 shall be handed over by the manufacturer to the approved bodies involved.

(2) The manufacturer shall make a declaration of conformity, stating that the construction product is in conformity with the provisions of the European technical approval ETA-10/0165 issued on 19.04.2010.

¹² The "control plan" is a confidential part of the European technical approval and only handed over to the approved body involved in the procedure of attestation of conformity. See section 3.2.2.

3.3.2 Tasks for the approved bodies

(1) The approved bodies shall perform the following tasks in accordance with the provisions of the "control plan":

- initial type-testing of the product (for system 1),
- initial inspection of factory and of factory production control (for systems 1 and 2+),
- continuous surveillance, assessment and approval of factory production control (for systems 1 and 2+).

(2) The approved body shall retain the essential points of its actions referred to above and state the results obtained and conclusions drawn in a written report.

(3) The approved certification body involved by the manufacturer shall issue an EC certificate of conformity of the factory production control stating the conformity with the provisions of this European technical approval.

(4) The approved certification body involved by the manufacturer shall issue an EC certificate of conformity of

- the product (for system 1) or
- the factory production control (for system 2+)

stating the conformity with the provisions of this European technical approval.

(5) In cases where the provisions of the European technical approval and its control plan are no longer fulfilled the certification body shall withdraw the certificate of conformity and inform Deutsches Institut für Bautechnik without delay.

3.4 CE marking

The CE marking shall be affixed on the product itself and/or on the label attached to it; packaging; accompanying commercial document. The letters "CE" shall be followed by the identification number of the approved certification body, where relevant, and be accompanied by the following additional information:

- the name and address of the producer (legal entity responsible for the manufacture),
- the last two digits of the year in which the CE marking was affixed,
- the number of the EC certificate for the factory production control,
- the number of the European technical approval,
- essential properties:
 - reaction-to-fire class,
 - admissible contact material,
 - admissible levels of serviceability and
 - resistance to media shall be given with the wording "*Resistance to media in accordance with Annex 2 of the ETA-10/0165*".

4 Assumptions under which the fitness of the product for the intended use was favourably assessed

4.1 Manufacturing

(1) For the manufacture of the sealing system the provisions of this approval shall apply.

(2) The preparation of the sealing system may only be performed by the manufacturing plant Sika Deutschland GmbH", plant-No: DE 18, Germany according to the information deposited.

(3) The European technical approval is issued for the product on the basis of agreed information, deposited with Deutsches Institut für Bautechnik, which identifies the product which has been assessed and judged.

(4) Changes to the sealing system, there components or production process, which could result in this deposited information being incorrect, should be notified to Deutsches Institut für Bautechnik before the changes are introduced. Deutsches Institut für Bautechnik will decide whether or not such changes affect the approval and consequently the validity of the CE marking on the basis of the approval and if so whether further assessment or alterations to the approval shall be necessary.

4.2 Installation

4.2.1 Conditions for the installation

(1) The sealing system is planned and designed by expert designers only.

(2) The joints are designed such that they can be controlled during subsequent use.

(3) For the proper installation of the sealing system the manufacturer of the sealing system draws up installation and handling instructions, which are deposited as part of the technical documentation with Deutsches Institut für Bautechnik.

(4) The sealing system can be connected to the joint sealing system according to ETA-10/0151.

(5) The additional instructions and technical advice given by the manufacturer have paid attention to, e.g. concerning the condition of the gluing area and adjacent building components or surface sealants.

(6) The serviceability for the respective intended use results from the contact material and the indicated levels and/or performance classes of the categories of use.

(7) Controllable calculations and construction drawings (e.g. joint plans) are made up taking account of the requirements at national level of the respective Member states and the stresses and loadings to be expected.

(8) The movable joints are arranged such that the admissible extension, compression and shear distances referred to in Annex 3, Table 2 are complied with.

(9) The following is considered for design and dimensioning:

- Sealing systems are arranged such that they can be used - within the scope of the stress level "low" and "medium" according to Annex 2 - with liquid chemicals (substances hazardous to water) or that an accumulation of a mixture of dirt and liquid chemicals (substances hazardous to water) is avoided on the sealing system.
- The concrete joint side walls shall have enough strength and load-bearing capacity that they are able to accept the occurring stresses acting on them through the sealing system.
- The sealing surfaces and/or constructions to be connected shall be designed such that the admissible deformations according to Annex 3, Table 2 (e.g. due to temperature, residual shrinkage or creep) are observed.
- In accordance with the national requirements of the respective country, the sealing construction (e.g. uncoated concrete, pouring asphalt or semi-rigid pavements) in which and/or on which the sealing system is installed may only show limited penetration depths of liquids. The characteristic penetration depth of the respective liquid in the sealing construction or sealing layer, e.g. made of concrete, shall be smaller than the protected area of the joint side wall " d_H " (see also Annex 5).

4.2.2 Processing

- (1) Fitness for use of the installed sealing systems can only be assumed, if the processing is performed according to the provisions of this ETA and according to the supplementing installation and processing instructions by the manufacturer.
- (2) It has to be checked whether the system components of the sealing system and the respective primer were not exchanged.
- (3) It is to be guaranteed that the admissible geometry of the joint construction especially the joint band according to Annex 3, Table 1 will be warranted observed.
- (4) Before the installation of the sealing system the suitability of the surrounding joint areas and the surfaces of the constructions to be connected to it have ascertained.
 - In the case of concrete sealing constructions the concrete of the contact surfaces shall have reached at the time of jointing at least 70% of the 28-days-strength and be at least 7 days old.
 - The surrounding joint areas shall be dry and may not show any impurities.
 - Accumulations of precipitation behind already installed sealants have to be prevented.
 - The surface temperature of the building elements in the area of the joints shall be at least 3 K above thawing temperature during the installation of the joint sealing compound.
 - The primer shall be applied evenly on the respective gluing area. The primer will be applied according to the installation instructions by the manufacturer
 - The classification of the different primers to the respective contact materials (concrete, polymer-concrete, uncoated and/or coated cast-steel, asphalt, semi-rigid pavements) shall be strictly observed.
- (5) When installing the sealing system the specifications made by the manufacturer or the designing engineer (see e.g. the drawing of the joint) shall be observed.
- (6) At temperatures of the building component below 5 °C and above 40 °C jointing may not be performed. The temperature of the single sealing components has to be at least 10 °C at the time of installation.
- (7) The components of the primer and the adhesive membrane shall be mixed according to manufacturer's instructions.
- (8) The primer and the adhesive membrane may not be applied on layers of condensation moisture.
- (9) The time interval given in Annex 3, Table 2, between applying the primer and installing the adhesive membran (airing out) may not fall below or be exceeded.
- (10) Joints in horizontal areas have to be filled with a suitable material (e.g. closed-cell PE-round cord) up to the surface of the joint to avoid a hanging down of the join band.
- (11) The release for mechanical and chemical stresses of the sealing construction may only be performed after the period indicated in Annex 3, Table 2 after complete installation of the sealing system.

4.2.3 Installing firm and the attestation of conformity of the installed sealing system

(1) The installation of the sealing system shall be carried out by firms only who (including their specialists) are authorized and trained by the holder of the approval. Further requirements for the installing firm can result from national provisions of the Member States, e.g. in G.: *Fachbetriebspflicht* ('obligation of a specialist firm').

(2) The attestation of conformity of the installed sealing system with the determinations of this ETA and according to the supplementing installation and processing instructions by the manufacturer shall be given with a declaration by the installing firm on the basis of the following controls:

- Control, whether the right system components for the sealing system were used as well as their marking according to section 3.3.
- Control of the execution according to section 4.2.6.

(3) The results of controls shall be recorded and evaluated by the installing firm, e.g. according to Annex 8). The records shall include at least the following information:

- Sealing system: <<Sika sealing band system Sika Tank FB-25>>
- Approval-number: ETA-10/0165
- Approval holder: *Name, Address*
- Installation on: *Date*
- Installing firm: *Name, Address*
- Type of control or test (see section 4.2.6)
- Date of the test
- Result of the control and tests and comparison with the requirements
- Provisions to which the sealing system conforms:
 - reaction-to-fire class
 - indication of levels of trafficability
 - the resistance to media shall be described with the wording "*in accordance with Annex 2 of the ETA-10/0165*". Special notes applicable to the use of the product:
"Repair work /retrofitting is admissible only according to this approval. Furthermore the corresponding instructions of the manufacturer shall be taken into account."
- Name of, and position held by, the person empowered to sign the declaration on behalf of the installing firm or of his authorized representative.

(4) During the installation of the sealing system the verification of the correct installation shall be documented by the construction manager or his authorized representative. The documentation and the declaration of the installing firm shall be kept with the construction file of the respective object. They shall be laid out ready during the period of construction. On request they shall be presented to the approval body, the relevant construction supervision authority and the expert personnel in accordance with the national regulations of the Member States.

(5) If there are insufficient test results the installing firm shall immediately take the necessary actions to stop the deficiency. After the corrective action the controls shall be repeated immediately - as far as technically possible - to verify that the rectification of deficiencies.

4.2.4 Control of the execution

(1) Before, during and after the installation of the sealing system the following controls are made:

(2) Before the installation:

- For sealing layers made of concrete the strength class of concrete and the water-cement ratio according to EN 206 and/or according to the national stipulations of the respective countries (e.g. G.: according to the *DAfStb Richtlinie "Betonbau im Umgang mit wassergefährdenden Stoffen"* ('Concrete construction for handling substances hazardous to water')) shall be proven before placing the sealing system on site.
- Control of the joint width, the joint distance according to Annex 1 and 3, respectively, of the design documents e.g. design of the joint (see section 4.2.1) and/or the processing instructions by the manufacturer.
- Control of the condition of the contact areas (bond areas). Dirt accumulations shall be removed thoroughly before the installation.
- Determination of the surface temperature and comparison (3 K above thawing temperature) in accordance with section 4.2.2.
- Control of the surface levelling top edge of the joint filling material according to 4.2.2(10).
- At the repair of joint sealing systems or cracks the suitability has to be controlled in accordance with the determinations of sections 1.1 and 1.2 and where necessary the type of the sealing compound according to section 4.3.

(3) After the installation:

- The installed sealing system is examined in full length.
- Control that the joint band does not hang down more than 2 mm in the middle of the non treaded flexible area.

4.3 Repair works

4.3.1 Repair of the sealing system

(1) Only firms according to clause 4.2.3 (1) are charged with the repair works.

(2) The section to be repaired shall be separated from the intact section by conducting a vertical cut.

(3) The defective joint material shall be removed completely. The surface around the joint area shall be repaired in accordance with the determinations of section 4.2.2 and prepared for the gluing of the sealing system. If using repair systems made of concrete with polymer additions or polymer-concrete, the evidence of suitability shall be furnished of these repair systems has to be provided in accordance with the national regulations of the Member States (e.g. in G.: national approval)

(4) The determinations of section 4.1 and 4.2 will be complied with.

4.3.2 Repair of joint sealing systems and/ or cracks

(1) Only firms according to clause 4.2.3 (1) are charged with the repair works.

(2) The area around the joint and / or cracks have to meet the determinations of sections 1.1 and 1.2 and/ or they are repaired and prepared for the on gluing of the sealing system, taking into consideration the determinations of sections 4.1 and 4.2.

(3) The damaged joint sealing compound could be left into the joint, if

- the force free movements of the joint building constructions are given,
- the damaged joint sealing compound does not limit the movements of the joint band and
- the contact in non treaded flexible area of the joint band will be prevented by a separation layer (e.g. PE-folia or silicon paper).

(4) If the contact between the joint band and the damage joint sealing system can not be avoided the evidence the chemical compatibility has to be positively performed before installation.

4.4 Responsibilities for the manufacturer

(1) It is the responsibility of the holder of the approval to make sure that all those who use his sealing system will be appropriately informed about the specific conditions according to sections 1, 2, 4, and 5 including the annexes to this ETA, the installation and processing instructions by the holder of the approval and the not confidential parts of the technical documentation to this ETA.

(2) This information can be given by reproduction of the corresponding parts of the European technical approval.

5 Indications to the manufacturer

5.1 Packaging, transport and storage

(1) Packaging, transport and storage of the single components of the sealing system shall be such that the fitness for the intended use will not be affected. All components of the sealing system and the respective primer shall in particular be stored in closed original containers/packs protected against moisture. The maximum storage time indicated on the containers/packs shall be observed.

(2) The sealing bands shall be stored as erected coils. During the storage the bands should be not squeezed.

(3) The information on requirements from other fields of the law (e.g. law relating to hazardous substances and/or law relating to transport)) given on the containers/packs shall be observed.

(4) The components of the sealing system shall not be exposed to direct solar radiation. They are to be stored such that the temperature of the material at the time of processing is higher than +10 °C and lower than +40 °C.

(5) The additional to the provisions of this ETA the instructions and technical advice given by the manufacturer have to be taken into account.

5.2 Use, maintenance, repair

(1) In order to ensure the fitness for use of the sealing system, the measures described in the following sections are recommended. It is the task of the manufacturer to make sure that all parties involved are adequately informed.

(2) The operator of the respective facility establishes operating instructions including, among others, the description of the necessary measures

- for the control of the proper condition
- for ensuring proper operation
- for maintenance and repair

of the joints as well as the description of measures to be taken in case of damage. The inspection intervals are specified according to the stress levels given in Annex 2 in conjunction with Annex 7 of this ETA. The inspection results are documented.

(3) Dripping losses and/or accumulations of already minor liquid quantities are directly removed.

(4) Leaked out liquid chemicals will immediately be bound with suitable means. The polluted bonding agent is taken up and recycled duly and without loss or is disposed of. Appropriate materials and/or employment devices are specified in the operating instructions and are constantly ready in sufficient quantity. For the disposal and treatment, respectively, of the materials resulting in waste reference is made to the applicable regulations of the respective Member State (e.g. in G.: Abfallgesetz (*Waste Management Law*)).

(5) Before placing into operation and, if necessary, after every repair work and if necessary after required rectification of deficiencies, the inspections for the putting into operation are carried out as follows:

- The inspection for the putting into operation is carried out by expert personnel only. Further requirements for the individuals can result from national regulations of the Member States.
- The person put in charge of the inspection will constantly be kept informed on the process of the work. The person is given the possibility to participate in the controls of the sealing system before and after the installation according to section 4.2.4 and to evaluate the results of the controls.
- Checking the condition of the installed sealing systems is done via visual inspection of the surface of all joints of the respective sealing construction.
- The person put in charge of the inspection examines the intended control intervals of the operating instructions by the operator of the respective facility.

(6) One year after every start-up inspection and then every five years recurring inspections shall be performed as follows:

- The recurring inspections are carried out by expert individuals. Further requirements for the individuals can result from national regulations of the Member States.
- The investigation of the condition of the sealing systems is done via visual check of the sealing in all areas of the respective sealing construction.
- On the basis of the documentation in accordance with section 5.2(2) it is checked whether
 - the check intervals were kept,
 - the specifications of the operating instructions are observed, and
 - no longer contact has occurred between the sealing system and the substances hazardous to water in the course of use.

(7) If doubts arise about the tightness of the sealing system (e.g. due to softening of the surface of the sealing band) further examinations become necessary. For that purpose samples (drilling core) will be taken from the section concerned, if need be. It can be done without the taking of samples from the soil underneath the sealing system; if demonstrably no complete penetration of the sealing system occurred by liquids chemicals.

(8) Further national regulations of the Member States shall remain unaffected.

6 Recommendations for the operator of a facility for storing, filling and handling of liquid chemicals (substances hazardous to water)

(1) Reference is made to the necessity of a permanent surveillance by the operator of the facility for tightness and operability of the sealing system in accordance with the requirements of the national regulations of the respective Member State.

(2) An operating instruction shall be prepared by the operator of the respective facility which takes the following points into account:

- The contents of the regulations to be applied by the employee working in these fields will be presented in the operating instructions in a comprehensible and clear way and be laid out or put up at a suitable place of the plant. The operating instruction can be part of operating instructions in accordance with other fields of law of the respective Member States.
- The employees working in these fields will be instructed in the possible threats to water when storing, filling and handling of liquid chemicals (substances hazardous to water) as well as in the measures of hazard control. Before working in this field, they will be instructed before working with these substances and afterwards at least once per year.
- All essential measures of control by the operator, the maintenance and the repair will be specified in the operating instructions. The realization of the measures will be noted in each case in the company journal.

- In this operating instruction the operator lays down his inspection intervals with regard to the stress level specified in this ETA in accordance with Annex 2 in conjunction with Annex 7. These records are ready and will be presented to the person responsible according to the national regulations in force of the respective Member State.
- (3) The operator of a facility for the storing, filling and handling of liquid chemicals (substances hazardous to water) commissions only enterprises with maintenance, repair and cleaning of the joint sealing systems according to section 4.2.3(1).
- (4) After each repair work and/or touch up of a larger extent a start-up check will be carried out and the recurring test shall be repeated by the person charged with the test, respectively, in accordance with the effective national regulations of the respective Member State.
- (5) The sealing system is only to use for traffic with pedestrians.

Dipl.-Ing. Georg Feistel
Head of the Division Construction Engineering
of Deutsches Institut für Bautechnik
Berlin, 19 April 2010

beglaubigt
Dr. Kluge

Sika FB-25

Sika sealing band system Sika Tank FB-25 used in facilities for the storage, handling and filling of liquid chemicals (substances hazardous to water) is used on the following contact materials:

- **concrete,**
- **polymer-concrete based on UP-resin,**
- **asphalt,**
- **semi-rigid pavements**
- **and uncoated or coated parts made of cast-steel**

Sika sealing band system Sika Tank FB-25

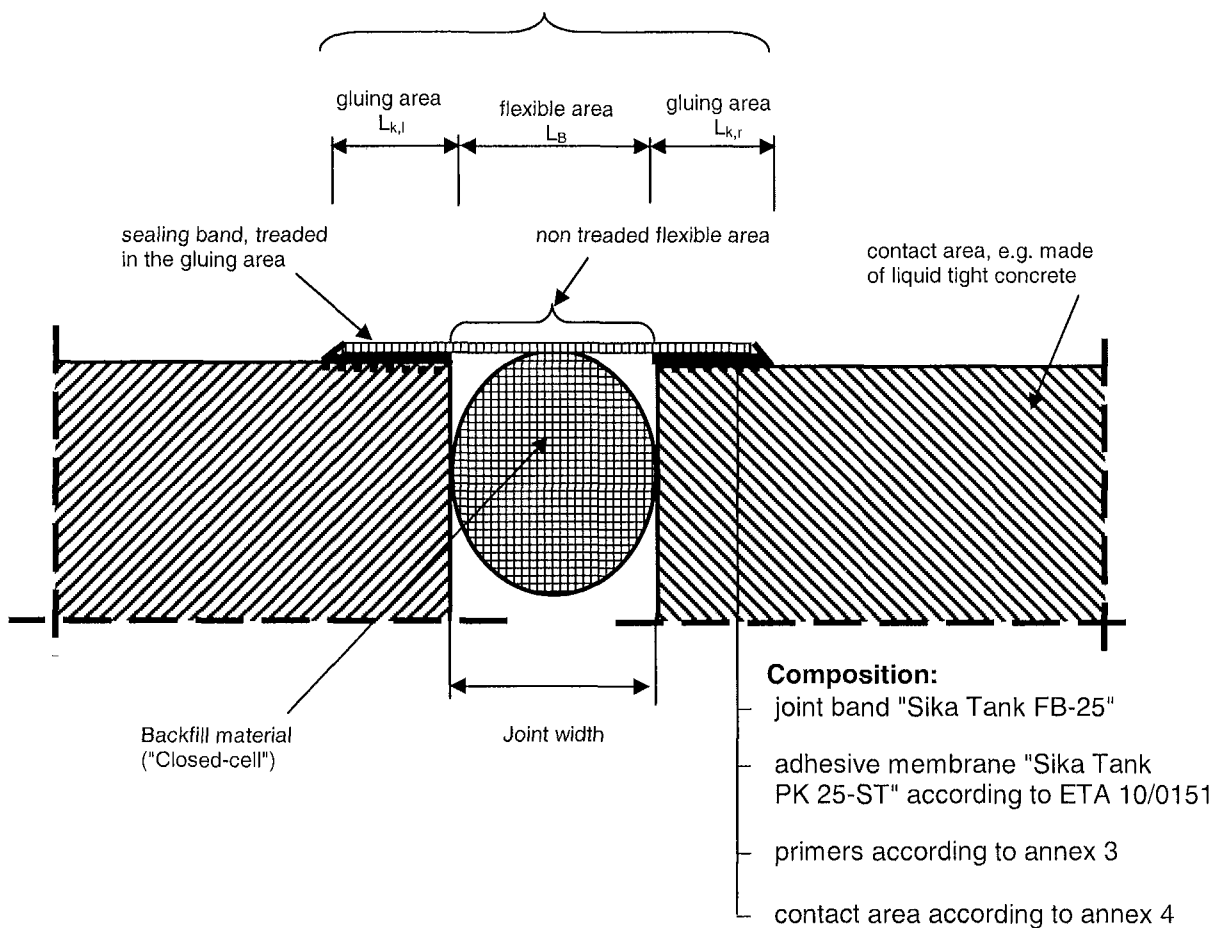

The Sika sealing band system Sika Tank FB-25 is only permitted for traffic with pedestrians (see Annex 3, Table 2).

Sika sealing band system Sika Tank FB-25 to be used in facilities for storage, handling and filling of substances hazardous to water

Annex 1
of the European technical approval

Product and built-in state

ETA-10/0165

The sealing system used in facilities for the storage, handling and filling of liquid chemicals (substances hazardous to water) is impermeable and chemically resistant to the following liquids (stress level: S₁, H₁, and F₁ "low" and S₂, H₂ and F₂ "medium" according to CUAP 06.05/19), see also Annex 7).

Table 1: List of the liquids for the stress levels S₁, H₁ and F₁ "low"

Group No.	Liquids
DF 10 ⁷⁾	Mineral acids up to 20 % as well as acidic, hydrolysing inorganic salts in aqueous solution (pH < 6), except hydrofluoric acid and oxidising acids and their salts
DF 12 ⁷⁾	Aqueous solutions of inorganic non-oxidising salts with a pH value between 6 and 8

⁷⁾ The usability was verified for the test period of **24 hours**.

Table 2: List of liquids for the stress levels S₂, H₂ and F₂ "medium"

Group No.	Liquids
DF 1	Gasoline for spark ignition engines, super and normal (according to EN 228:2004-03) with a maximum 5 percentage by volume of bio-alcohol
DF 1a	Gasoline for spark ignition engines, super and normal (according to EN 228:2004-03) with a maximum 20 percentage by volume of bio-alcohol
DF 2	Aviation gasoline
DF 3	<ul style="list-style-type: none"> – Fuel EL – Unused combustion engine oil – Unused motor vehicle gear oil – Mixture of saturated and aromatic hydrocarbons with an aromatic content ≤ 20 wt.-% and a flash point > 55 °C
DF 3a	Diesel fuel (according to EN 590: 2004-03) with a maximum of 5 volume percent of bio-diesel fuel
DF 3b	Diesel fuel (according to EN 590: 2004-03) with a maximum of 20 volume percent of bio-diesel fuel
DF 4	All hydrocarbons and mixtures containing benzene with a maximum of 5 volume percent of benzene, except fuels
DF 4a	Benzene and mixtures containing benzene
DF 4b	Crude oils
DF 4c	Used internal combustion engine oils and used vehicle gear oils with a point of ignition of > 55 °C
DF 5	Monovalent and polyvalent alcohol (up to a maximum of 48 volume percent of methanol), glycol ethers
DF 5a	alcohol and glycol ethers
DF 5b	Monovalent and polyvalent alcohol ≥ C ₂
DF 7	All organic ester and ketone
DF 7a	Aromatic ester and ketone
DF 7b	bio-diesel fuel
DF 11	Inorganic lye as well as alkaline hydrolysing inorganic salts in aqueous solution (pH > 8), except oxidising salt solutions (e.g. hypochlorite)

Sika sealing band system Sika Tank FB-25 to be used in facilities for storage, handling and filling of substances hazardous to water

Annex 2
of the European
technical approval

List of liquids

ETA-10/0165

Table 1: Dimensions of the joint construction and/ or sealing system

No	Characteristics	Dimensions in mm																			
		20	25	30	35	40	50	60	70	80	90	100	110	120	130	140	150	160	180	200	
1	Band width																				
2	Band thickness	1,5					2,0					3,0									
3	non treaded flexible area	8	13	18	21	24	30	36	42	48	52	60	70	80	90	100	110	120	140	160	
4	Minimum gluing area width	2 x 6			2 x 7	2 x 8	2 x 10	2 x 12	2 x 14	2 x 16	2 x 18	2x 20									
5	maximum open joint width	8	13	18	21	24	30	36	42	48	52	60	70	80	90	100	110	120	140	160	

Table 2: Characteristics of the sealing band and/ or the sealing system

No	Characteristic	Unit	Comments		
1	density Of the sealing band	[g/cm³]	1,84 ± 0,03 (free of pores)		
2	hardness (Shore A) Without stress	[unit of hardness]	30 bis 40		
3	tear strength in standard climate at maximum force	[N/mm²]	2,9 + - 0,5		
4	extension in standard climate at maximum force	[%]	min. 800		
5	storage time	[days]	Without limit, taking the instructions of the manufacturer into consideration		
6	time of airing out (at 23°C) of Primer ¹⁾	[minutes]	Concrete and cast-steel (coated) ²⁾	Polymer-concrete (UP-resin basis) and cast-steel (uncoated)	Asphalt and semi-rigid pavements
			60	30	240
7	minimum cure time Of the adhesive membrane	[hours]	24 (depending on weather)		
8	waiting time until full stress	[hours]	24 (depending on weather)		
9	shade	[-]	gray and black		
10	backfill material	[-]	according to ETA and to the additional provisions by the manufacturer		
11	surface temperature of the pavement sealing system in areas of joints during installation	[K]	≥ 5°C und ≤ 40°C, ≥ 3 K above temperature of dew point		
12	admissible deformations as a result of extension, compressive strain and shear stress ³⁾ – parallel joints – cross and tee- intersections		<u>non treaded flexible area</u> ⁴⁾ 2		
13	The effects on the joint width as a reaction of the deformation behaviour of the connecting sealing construction (e.g. as a result of temperature) have to be taken into account.				
14	for the period of reaction the sealing system shall be protected from atmospheric exposure in accordance with the instructions by the manufacturer.				
15	reaction to fire class "E", classification according to EN 13501-1				
16	– Level of trafficability "t0": suited for traffic with pedestrians only, joint width: up to 15 mm				
	– Level of trafficability "t1": suited for traffic with pedestrians only, , joint width: greater than 15 mm				

- 1) - Polymer-concrete (UP-resin basis) and cast-steel (uncoated): Sika Tank Primer PK-2
 - Concrete and cast-steel (coated): Sika Tank Primer PK-3
 - Asphalt and semi-rigid pavements: Sika Tank Primer PK-3S
- 2) only permissible with corrosion protection based on alkyd resin, e.g. "Zinkphosphat-Rost- und Haftprimer" of the firm A. Harbsmeyer KG.
- 3) simultaneous extension and/or compressive stress and shear:
 Taking account of the real stresses, joint sealing compounds may be used placing more emphasis on the extension and/or compression capacity or on the shear capacity.
- 4) according to annex 3, Table 1

Sika sealing band system Sika Tank FB-25 to be used in facilities for storage, handling and filling of substances hazardous to water	Annex 3 of the European technical approval
Dimensions and characteristics of the sealing band and/ or sealing system	ETA-10/0165

Table 1: Admissible contact materials

No	Contact materials	Comments
1	Sealing layers made of asphalt ¹⁾ The bitumen used for the asphalt has to be clear and unblended. The content of BaP has to be less than 5 mg BaP/kg.	Contact materials: - according to the statutory provisions implementing Directives of the European Community, which include the specific requirements of the building authority as well as the law relating to water and which bear the marking of the European Community (CE marking) and/or - according to the intended national provisions of the respective countries.
2	Semi-rigid pavements ²⁾	
3	sealing constructions made of polymer concrete on UP resin base ³⁾	
4	sealing constructions made of uncoated and/or coated ⁴⁾ cast-steel	
5	concrete ⁵⁾ : - pre-fabricated elements	
6	concrete ⁶⁾ : - in-situ concrete	concrete: - according to Annex 4, Table 2 and - according to the intended national provisions of the respective countries

- 1) e.g.: pouring asphalt, granted and marked in accordance with an European technical approval for sealing layers made of pouring asphalt for the use in facilities for the storage, handling and filling of substances hazardous to water
- 2) e.g.: semi-rigid pavements, granted and marked in accordance with an *allgemeine bauaufsichtliche Zulassung* ('national technical approval') (G) for sealing layers made of semi-rigid pavements as a component of an area (surface) sealing system for the use in facilities for the storage, handling and filling of substances hazardous to water
- 3) e.g.: polymer-concrete, granted and marked in accordance with an *allgemeine bauaufsichtliche Zulassung* ('national technical approval') (G) for gutters (drains) made of polymer-concrete for the use in facilities for the storage, handling and filling of substances hazardous to water
- 4) e.g. coated cast-steel, alkyd resin-based corrosion protection, e.g. "Zinkphosphat-Rost- und Haftprimer" by A. Harbsmeyer KG
- 5) e.g.: vehicle pre-fabricated load-bearing elements made of liquid tight concrete, granted and marked in accordance with an European technical approval for the use in facilities for the storage, handling and filling of substances hazardous to water
- 6) e.g.: liquid tight slabs made of in-situ concrete, granted and marked in accordance with an *allgemeine bauaufsichtliche Zulassung* ('national technical approval') (G) for the use in facilities for the storage, handling and filling of substances hazardous to water

Table 2: Properties of the contact materials

No	Property	Characteristic value	Comments
1	2	3	4
contact materials according to Annex 4, Table 1:			
1	migration behaviour	characteristic penetration depth "e _{ik} "	In accordance with the national requirements of the respective countries the characteristic penetration depth "e _{ik} " ($e_{ik} = e_{tm} \cdot 1.35$) of the respective test liquid in the concrete has to be smaller than the joint side wall protected by the joint sealing compound (d _H), see also Annex 5, Figure 2.
In addition for concrete according to Annex 4, Table 1, No 6:			
2	compressive strength class	≥C30/37 ≤C50/60	EN 206-1, Table 7
3	maximum admissible water/cement ratio	≤ 0.5	EN 206-1, Table F.1

Sika sealing band system Sika Tank FB-25 to be used in facilities for storage, handling and filling of substances hazardous to water

Annex 4
of the European technical approval

Admissible contact materials and there properties

ETA-10/0165

Figure 1: Admissible installation principles:

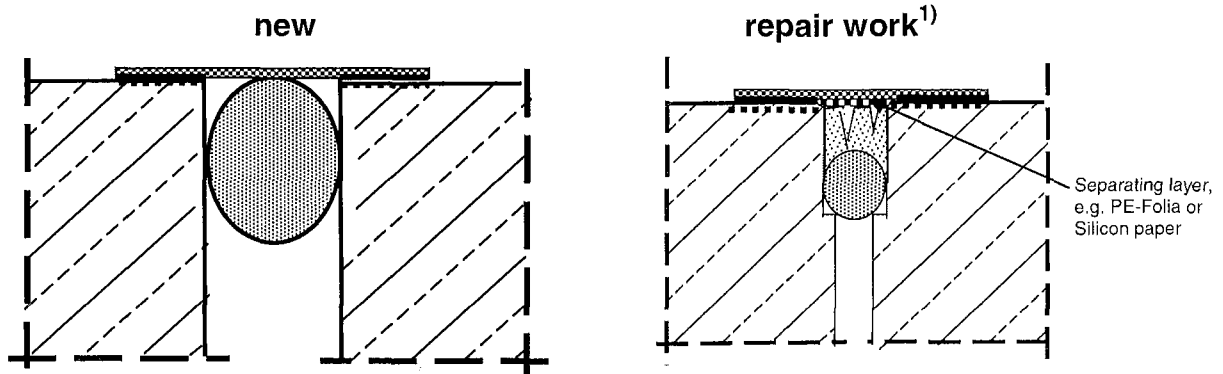

¹) According to the provisions of this approval, section 4.3

Figure 2: Bonding and migration behaviour in the area of the installed sealing band system

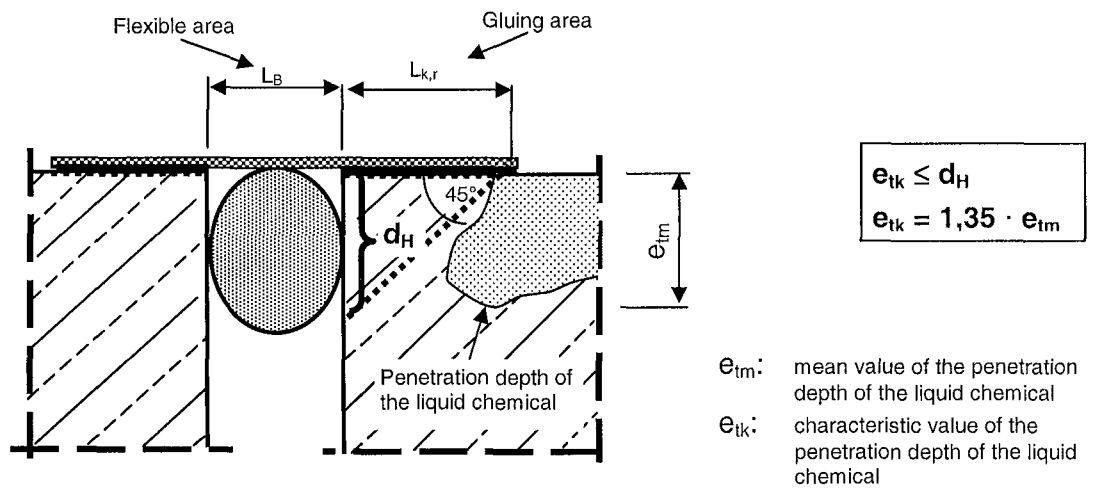

Sika sealing band system Sika Tank FB-25 to be used in facilities for storage, handling and filling of substances hazardous to water

Admissible installation prinzipes and bonding and migration behaviour

Annex 5
of the European technical approval

ETA-10/0165

No	Confirmation by the executing company			
1.	Project - Name..... - Size			
2.	storage substance:			
3.	Sealing system:	"Sika sealing band system Sika Tank FB-25" used in facilities for storage, handling and filling of liquid chemicals (substances hazardous to water)"		
4.	Approval:	ETA-10/0165 dated on 19.04.2010		
5.a	Manufacturer:	Sika Deutschland GmbH Manufacturer plant No.: DE 18, Germany Phone: ++49(0)7118009-0, Fax: ++49(0)7118009-321		
5.b	Name of company installing according to			
	ETA section 4.2.3 (1):			
5.c	Construction period:			
		Confirmation		
6.	The qualified personnel of the executing company were instructed by the holder of the European technical approval mentioned above in the proper processing.			
7.	Evaluations and controls before and during the installation of the sealing system			
	a) Before the installation:	Note the characteristic values of the building side journal		
	- Compare concrete compressive strength class ($\geq C30/37$) and water-cement ratio ($\leq 0,5$) with the documentation of the building side journal.	C/..... / w/c-ratio:		
	- joint width / joint distance / depth of the joint space [mm]:/..... /		
	- surface temperature / thawing temperature [$^{\circ}C$]:/.....		
	- bond areas/contact areas are dry:	yes / no		
	- bond areas/contact areas are free from all contaminations:	yes / no		
	- system component in accordance with the approval:	yes / no		
	- Marking of all components in accordance with the approval:	yes / no		
	b) During and after the installation::			
	- Records of the weather conditions are enclosed:	yes / no		
	- Visual test: (delete as applicable)	<table border="1" style="display: inline-table; border-collapse: collapse;"> <tr><td style="padding: 2px;">no objections</td></tr> </table> <table border="1" style="display: inline-table; border-collapse: collapse; margin-left: 20px;"> <tr><td style="padding: 2px;">objections (see comments)</td></tr> </table>	no objections	objections (see comments)
no objections				
objections (see comments)				
	- side wall adhesion acc. to section 4.2.4(3): (delete as applicable)	<table border="1" style="display: inline-table; border-collapse: collapse;"> <tr><td style="padding: 2px;">no objections</td></tr> </table> <table border="1" style="display: inline-table; border-collapse: collapse; margin-left: 20px;"> <tr><td style="padding: 2px;">objections (see comments)</td></tr> </table>	no objections	objections (see comments)
no objections				
objections (see comments)				
Remarks:				
Date:		Signature / firm stamp		
Sika sealing band system Sika Tank FB-25 to be used in facilities for storage, handling and filling of substances hazardous to water		Annex 6 of the European technical approval		
Example of an installation report for an installed joint sealing system		ETA-10/0165		

Stress levels for the effective hourly capacity of water-contaminating substances *)

The level of chemical exposure shall be chosen in accordance with the following Tables 1 and 2. The Tables indicate the time and/or the frequency (period of exposure and frequency, respectively) as well as the appropriate time (test period) during which the test liquid (see list of test liquids) acts on the sealing bands (during the test). The period of exposure shall be chosen by the manufacturer. Following successful performance testing, the characteristic technical values related to the respective stress level shall be specified in the approval.

Table 1: Stress level related to the period of stress during storage in a test liquid

Stress level	Description	Period of stress	Test period
1	2	3	4
Storage (S)			
S₁	low	up to 8 hours	8 hours
S₂	mean	up to 72 hours	72 hours
S₃	high	up to 3 months	≥ 28 days ¹⁾

¹⁾ As far as no change is visible. Otherwise the test period can be prolonged until stability of mass, however up to 42 days at the most.

Table 2: Stress level related to the frequency of filling and/or handling period of test liquids

Stress level	Description	Period of stress	Test period
1	2	3	4
Handling (H) and Filling (F)			
H₁, F₁	low	maximum of 4 times per year	8 hours
H₂, F₂	mean	maximum of 200 times per year	72 hours
H₃, F₃	high	more than 200 times per year	≥ 21 days ¹⁾

¹⁾ As far as no change is visible. Otherwise the test period can be prolonged until stability of mass, however up to 42 days at the most.

Sika sealing band system Sika Tank FB-25 to be used in facilities for storage, handling and filling of substances hazardous to water

Stress levels

Annex 7
of the European
technical approval

ETA-10/0165