

European Technical Approval ETA-11/0068

English translation prepared by DIBt - Original version in German language

Handelsbezeichnung <i>Trade name</i>	TEAM PRO Keilanker TPB <i>TEAM PRO Anchor Bolt TPB</i>
Zulassungsinhaber <i>Holder of approval</i>	TEAM PRO Dora Highway, Dora Trade Center BEIRUT LEBANON
Zulassungsgegenstand und Verwendungszweck <i>Generic type and use of construction product</i>	Kraftkontrolliert spreizender Dübel aus verzinktem Stahl in den Größen M6, M8, M10, M12, M16 und M20 zur Verankerung im ungerissenen Beton <i>Torque controlled expansion anchor made of zinc coated steel of sizes M6, M8, M10, M12, M16 and M20 for use in non-cracked concrete</i>
Geltungsdauer: <i>Validity:</i>	vom <i>from</i> bis <i>to</i>
Herstellwerk <i>Manufacturing plant</i>	21 February 2011 18 February 2016 Manufacturing plant No. 7

Diese Zulassung umfasst
This Approval contains

13 Seiten einschließlich 6 Anhänge
13 pages including 6 annexes

I LEGAL BASES AND GENERAL CONDITIONS

- 1 This European technical approval is issued by Deutsches Institut für Bautechnik in accordance with:
 - Council Directive 89/106/EEC of 21 December 1988 on the approximation of laws, regulations and administrative provisions of Member States relating to construction products¹, modified by Council Directive 93/68/EEC² and Regulation (EC) N° 1882/2003 of the European Parliament and of the Council³;
 - Gesetz über das In-Verkehr-Bringen von und den freien Warenverkehr mit Bauprodukten zur Umsetzung der Richtlinie 89/106/EWG des Rates vom 21. Dezember 1988 zur Angleichung der Rechts- und Verwaltungsvorschriften der Mitgliedstaaten über Bauprodukte und anderer Rechtsakte der Europäischen Gemeinschaften (Bauproduktengesetz - BauPG) vom 28. April 1998⁴, as amended by law of 31 October 2006⁵;
 - Common Procedural Rules for Requesting, Preparing and the Granting of European technical approvals set out in the Annex to Commission Decision 94/23/EC⁶;
 - Guideline for European technical approval of "Metal anchors for use in concrete - Part 2: Torque controlled expansion anchors ", ETAG 001-02.
- 2 Deutsches Institut für Bautechnik is authorized to check whether the provisions of this European technical approval are met. Checking may take place in the manufacturing plant. Nevertheless, the responsibility for the conformity of the products to the European technical approval and for their fitness for the intended use remains with the holder of the European technical approval.
- 3 This European technical approval is not to be transferred to manufacturers or agents of manufacturers other than those indicated on page 1, or manufacturing plants other than those indicated on page 1 of this European technical approval.
- 4 This European technical approval may be withdrawn by Deutsches Institut für Bautechnik, in particular pursuant to information by the Commission according to Article 5(1) of Council Directive 89/106/EEC.
- 5 Reproduction of this European technical approval including transmission by electronic means shall be in full. However, partial reproduction can be made with the written consent of Deutsches Institut für Bautechnik. In this case partial reproduction has to be designated as such. Texts and drawings of advertising brochures shall not contradict or misuse the European technical approval.
- 6 The European technical approval is issued by the approval body in its official language. This version corresponds fully to the version circulated within EOTA. Translations into other languages have to be designated as such.

¹ Official Journal of the European Communities L 40, 11 February 1989, p. 12
² Official Journal of the European Communities L 220, 30 August 1993, p. 1
³ Official Journal of the European Union L 284, 31 October 2003, p. 25
⁴ *Bundesgesetzblatt Teil I 1998*, p. 812
⁵ *Bundesgesetzblatt Teil I 2006*, p. 2407, 2416
⁶ Official Journal of the European Communities L 17, 20 January 1994, p. 34

II SPECIFIC CONDITIONS OF THE EUROPEAN TECHNICAL APPROVAL

1 Definition of the construction product and intended use

1.1 Definition of the product

The TEAM PRO Anchor Bolt TPB is an anchor made of electroplated galvanised steel in the range of M6, M8, M10, M12, M16 and M20 or hot dipped galvanised steel in the range of M8, M10, M12, M16 and M20 which is placed into a drilled hole and anchored by torque-controlled expansion.

An illustration of the product and intended use is given in Annex 1.

1.2 Intended use

The anchor is intended to be used for anchorages for which requirements for mechanical resistance and stability and safety in use in the sense of the Essential Requirements 1 and 4 of Council Directive 89/106 EEC shall be fulfilled and failure of anchorages made with these products would cause risk to human life and/or lead to considerable economic consequences. The anchor is to be used only for anchorages subject to static or quasi-static loading in reinforced or unreinforced normal weight concrete of strength classes C20/25 at minimum and C50/60 at most according to EN 206:2000-12.

It may be anchored in non-cracked concrete only.

The anchor may only be used in structures subject to dry internal conditions.

The provisions made in this European technical approval are based on an assumed working life of the anchor of 50 years. The indications given on the working life cannot be interpreted as a guarantee given by the producer, but are to be regarded only as a means for choosing the right products in relation to the expected economically reasonable working life of the works.

2 Characteristics of the product and methods of verification

2.1 Characteristics of the product

The anchor corresponds to the drawings and provisions given in Annexes 2 and 3. The characteristic material values, dimensions and tolerances of the anchor not given in Annexes 2 and 3 shall correspond to the respective values laid down in the technical documentation⁷ of this European technical approval.

The characteristic values for the design of anchorages are given in Annexes 5 and 6.

Each anchor is marked with the identifying mark of the manufacturing plant, the anchor identity, the anchor size and the maximum thickness of fixture for h_{ef} and $h_{ef,red}$ according to Annex 2.

The anchor shall only be packaged and supplied as a complete unit.

⁷ The technical documentation of this European technical approval is deposited at the Deutsches Institut für Bautechnik and, as far as relevant for the tasks of the approved bodies involved in the attestation of conformity procedure, is handed over to the approved bodies.

2.2 Methods of verification

The assessment of fitness of the anchor for the intended use in relation to the requirements for mechanical resistance and stability and safety in use in the sense of the Essential Requirements 1 and 4 has been made in accordance with the "Guideline for European technical approval of Metal Anchors for Use in Concrete", Part 1 "Anchors in general" and Part 2 "Torque-controlled expansion anchors", on the basis of Option 7.

In addition to the specific clauses relating to dangerous substances contained in this European technical approval, there may be other requirements applicable to the products falling within its scope (e.g. transposed European legislation and national laws, regulations and administrative provisions). In order to meet the provisions of the Construction Products Directive, these requirements need also to be complied with, when and where they apply.

3 Evaluation and attestation of conformity and CE marking

3.1 System of attestation of conformity

According to the Decision 96/582/EG of the European Commission⁸ system 2(i) (referred to as system 1) of the attestation of conformity applies.

This system of attestation of conformity is defined as follows:

System 1: Certification of the conformity of the product by an approved certification body on the basis of:

- (a) Tasks for the manufacturer:
 - (1) factory production control;
 - (2) further testing of samples taken at the factory by the manufacturer in accordance with a prescribed control plan;
- (b) Tasks for the approved body:
 - (3) initial type-testing of the product;
 - (4) initial inspection of factory and of factory production control;
 - (5) continuous surveillance, assessment and approval of factory production control.

Note: Approved bodies are also referred to as "notified bodies".

3.2 Responsibilities

3.2.1 Tasks for the manufacturer

3.2.1.1 Factory production control

The manufacturer shall exercise permanent internal control of production. All the elements, requirements and provisions adopted by the manufacturer shall be documented in a systematic manner in the form of written policies and procedures, including records of results performed. This production control system shall insure that the product is in conformity with this European technical approval.

The manufacturer may only use initial / raw / constituent materials stated in the technical documentation of this European technical approval.

⁸ Official Journal of the European Communities L 254 of 08.10.1996

The factory production control shall be in accordance with the control plan which is part of the technical documentation of this European technical approval. The control plan is laid down in the context of the factory production control system operated by the manufacturer and deposited with Deutsches Institut für Bautechnik.⁹

The results of factory production control shall be recorded and evaluated in accordance with the provisions of the control plan.

3.2.1.2 Other tasks of manufacturer

The manufacturer shall, on the basis of a contract, involve a body which is approved for the tasks referred to in section 3.1 in the field of in order to undertake the actions laid down in section 3.2.2 For this purpose, the control plan referred to in sections 3.2.1.1 and 3.2.2 shall be handed over by the manufacturer to the approved body involved.

The manufacturer shall make a declaration of conformity, stating that the construction product is in conformity with the provisions of this European technical approval.

3.2.2 Tasks for the approved bodies

The approved body shall perform the

- initial type-testing of the product,
- initial inspection of factory and of factory production control,
- continuous surveillance, assessment and approval of factory production control,

in accordance with the provisions laid down in the control plan.

The approved body shall retain the essential points of its actions referred to above and state the results obtained and conclusions drawn in a written report.

The approved certification body involved by the manufacturer shall issue an EC certificate of conformity of the product stating the conformity with the provisions of this European technical approval.

In cases where the provisions of the European technical approval and its control plan are no longer fulfilled the certification body shall withdraw the certificate of conformity and inform Deutsches Institut für Bautechnik without delay.

3.3 CE marking

The CE marking shall be affixed on each packaging of the anchor. The letters "CE" shall be followed by the identification number of the approved certification body, where relevant, and be accompanied by the following additional information:

- the name and address of the holder of the approval (legal entity responsible for the manufacturer),
- the last two digits of the year in which the CE marking was affixed,
- the number of the EC certificate of conformity for the product,
- the number of the European technical approval,
- the number of the guideline for European technical approval,
- use category (ETAG 001-1 Option 7),
- size.

⁹

The control plan is a confidential part of the European technical approval and only handed over to the approved body involved in the procedure of attestation of conformity. See section 3.2.2.

4 Assumptions under which the fitness of the product for the intended use was favourably assessed

4.1 Manufacturing

The European technical approval is issued for the product on the basis of agreed data/information, deposited with the Deutsches Institut für Bautechnik, which identifies the product that has been assessed and judged. Changes to the product or production process, which could result in this deposited data/information being incorrect, should be notified to the Deutsches Institut für Bautechnik before the changes are introduced. Deutsches Institut für Bautechnik will decide whether or not such changes affect the approval and consequently the validity of the CE marking on the basis of the approval and if so whether further assessment or alterations to the approval shall be necessary.

4.2 Design of anchorages

The fitness of the anchor for the intended use is given under the following conditions:

The anchorages are designed in accordance with the "Guideline for European technical approval of Metal Anchors for Use in Concrete", Annex C, Method A, under the responsibility of an engineer experienced in anchorages and concrete work.

Verifiable calculation notes and drawings are taking account of the loads to be anchored.

The position of the anchor is indicated on the design drawings (e.g. position of the anchor relative to reinforcement or to supports).

4.3 Installation of anchors

The fitness for use of the anchor can only be assumed if the anchor is installed as follows:

- Anchor installation carried out by appropriately qualified personnel and under the supervision of the person responsible for technical matters of the site,
- Use of the anchor only as supplied by the manufacturer without exchanging the components of an anchor,
- Anchor installation in accordance with the manufacturer's specifications and drawings and using the appropriate tools,
- Checks before placing the anchor to ensure that the strength class of the concrete in which the anchor is to be placed is in the range given and is not lower than that of the concrete to which the characteristic loads apply,
- Check of concrete being well compacted, e.g. without significant voids,
- Edge distances and spacing not less than the specified values without minus tolerances,
- Positioning of the drill holes without damaging the reinforcement,
- In case of aborted hole: new drilling at a minimum distance away of twice the depth of the aborted hole or smaller distance if the aborted drill hole is filled with high strength mortar and if under shear or oblique tension load it is not in the direction of load application,
- Cleaning of the hole of drilling dust in accordance with Annex 4,
- Anchor installation such that the effective anchorage depth is complied with. This compliance is ensured, if the thickness of fixture is not greater than the maximum thickness of fixture marked on the anchor in accordance with Annex 2 and the hexagon nut is placed at the end of the conical bolt as delivered by the manufacturer,
- Application of the torque moment given in Annex 3 using a calibrated torque wrench.

5 Responsibility of the manufacturer

The manufacturer is responsible to ensure that the information on the specific conditions according to 1 and 2 including Annexes referred to as well as sections 4.2 and 4.3 is given to those who are concerned. This information may be made by reproduction of the respective parts of the European technical approval. In addition all installation data shall be shown clearly on the package and/or on an enclosed instruction sheet, preferably using illustration(s).

The minimum data required are:

- Diameter of drill bit,
- Thread diameter,
- Maximum thickness of the fixture,
- Minimum effective anchorage depth,
- Minimum hole depth,
- Torque moment,
- Information on the installation procedure, including cleaning of the hole, preferably by means of an illustration,
- Reference to any special installation equipment needed,
- Identification of the manufacturing batch.

All data shall be presented in a clear and explicit form.

Georg Feistel
Head of Department

beglaubigt
Baderschneider

TEAM PRO Anchor Bolt TPB electroplated:

Sizes M6, M8, M10, M12, M16, M20

TEAM PRO Anchor Bolt TPB hot-dip galvanised:

Sizes M8, M10, M12, M16, M20

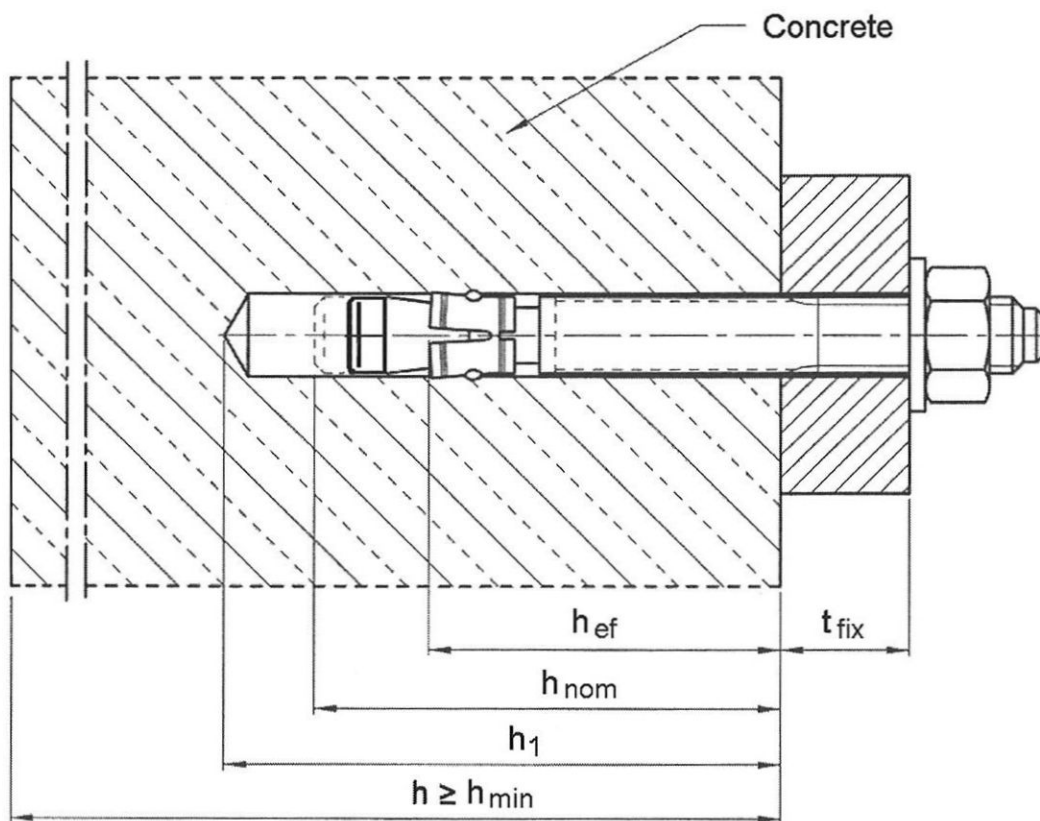
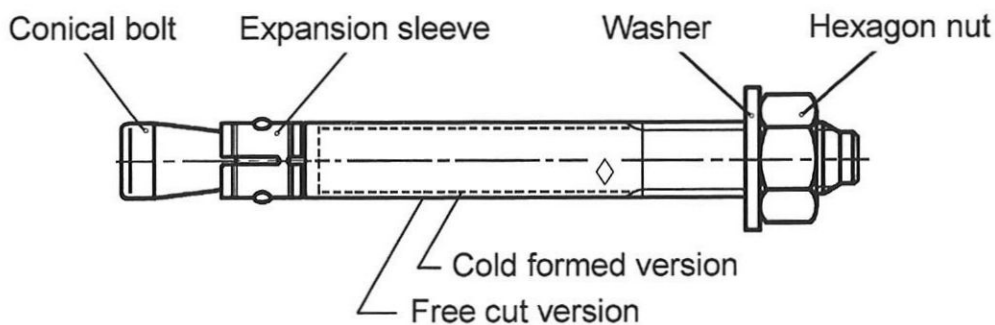

TEAM PRO Anchor Bolt TPB

Annex 1

Product and intended use

of European
technical approval

ETA-11/0068

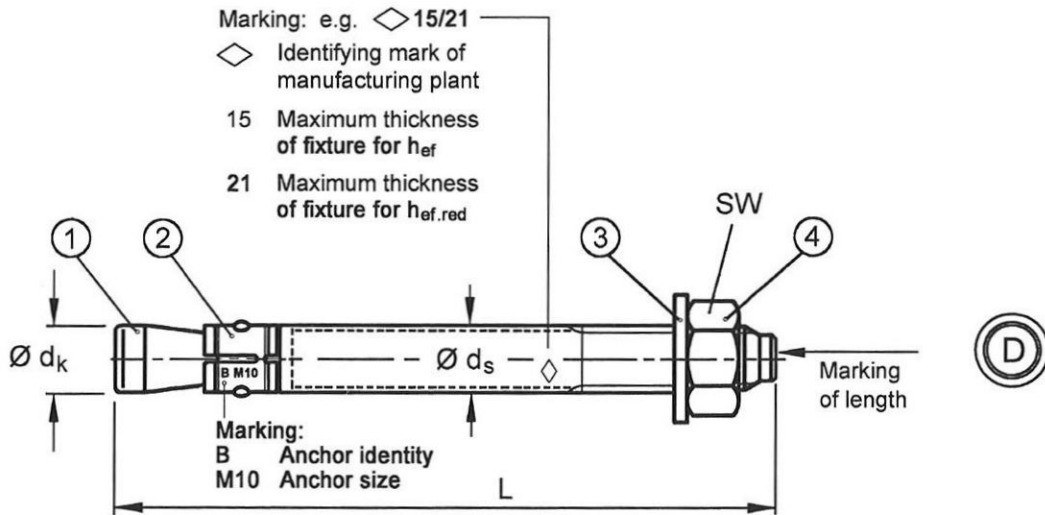

Marking of length	A	B	C	D	E	F	G	H	I	J	K	L	M
Length of anchor min \geq	38.1	50.8	63.5	76.2	88.9	101.6	114.3	127.0	139.7	152.4	165.1	177.8	190.5
Length of anchor max $<$	50.8	63.5	76.2	88.9	101.6	114.3	127.0	139.7	152.4	165.1	177.8	190.5	203.2

Marking of length	N	O	P	Q	R	S	T	U	V	W	X	Y	Z
Length of anchor min \geq	203.2	215.9	228.6	241.3	254.0	279.4	304.8	330.2	355.6	381.0	406.4	431.8	457.2
Length of anchor max $<$	215.9	228.6	241.3	254.0	279.4	304.8	330.2	355.6	381.0	406.4	431.8	457.2	483.0

Dimensions in mm

Table 1: Dimensions

Anchor size	$\varnothing d_k$	$\varnothing d_s$	Anchor length [L]		Wrench size [SW]
			Standard anchorage depth	Reduced anchorage depth	
M6	6	6 / 5.3 ¹⁾	$t_{fix} + 57.4$	$t_{fix,hef,red} + 47.4$	10
M8	8	8 / 7.1 ¹⁾	$t_{fix} + 66.4$	$t_{fix,hef,red} + 57.4$	13
M10	10	10 / 8.9 ¹⁾	$t_{fix} + 74.0$	$t_{fix,hef,red} + 68.0$	17
M12	12	12 / 10.7 ¹⁾	$t_{fix} + 97.3$	$t_{fix,hef,red} + 82.3$	19
M16	16	16 / 14.5 ¹⁾	$t_{fix} + 121.0$	$t_{fix,hef,red} + 103.0$	24
M20	20	20 / 18.2 ¹⁾	$t_{fix} + 142.7$	$t_{fix,hef,red} + 120.7$	30

¹⁾ cold formed version

Table 2: Material properties

Part	Designation	Material	
		Steel, electroplated $\geq 5 \mu m$ acc. to EN ISO 4042	Steel, hot-dip galvanised $\geq 40 \mu m$, acc. to EN ISO 1461
1	Conical bolt	Cold formed or machined steel	Cold formed or machined steel
2	Expansion sleeve	Steel, acc. to EN 10088, material No. 1.4301 or 1.4303	Steel, acc. to EN 10088, material No. 1.4301 or 1.4303
3	Washer	Steel	Steel
4	Hexagon nut	Property class 8 acc. to EN 20898-2	Property class 8 acc. to EN 20898-2

TEAM PRO Anchor Bolt TPB

**Dimensions,
Material properties**

Annex 2

of European
technical approval

ETA-11/0068

Table 3: Installation data

Anchor size			M6	M8	M10	M12	M16	M20
Nominal drill hole diameter	$d_0 =$	[mm]	6	8	10	12	16	20
Cutting diameter of drill bit	$d_{cut} \leq$	[mm]	6.40	8.45	10.45	12.5	16.5	20.55
Installation torque (Anchor Bolt TPB electroplated)	$T_{inst} =$	[Nm]	8	15	30	50	100	200
Installation torque (Anchor Bolt TPB hot-dip galvanised)	$T_{inst} =$	[Nm]	-	15	30	40	90	120
Diameter of clearance hole in the fixture	$d_f \leq$	[mm]	7	9	12	14	18	22
Standard anchorage depth								
Depth of drill hole	$h_1 \geq$	[mm]	55	65	70	90	110	130
Embedment depth	$h_{nom} \geq$	[mm]	49	56	62	82	102	121
Effective anchorage depth	$h_{ef} \geq$	[mm]	40	44	48	65	82	100
Reduced anchorage depth								
Depth of drill hole	$h_{1,red} \geq$	[mm]	45	55	65	75	95	110
Embedment depth	$h_{nom,red} \geq$	[mm]	39	47	56	67	84	99
Effective anchorage depth	$h_{ef,red} \geq$	[mm]	30	35	42	50	64	78

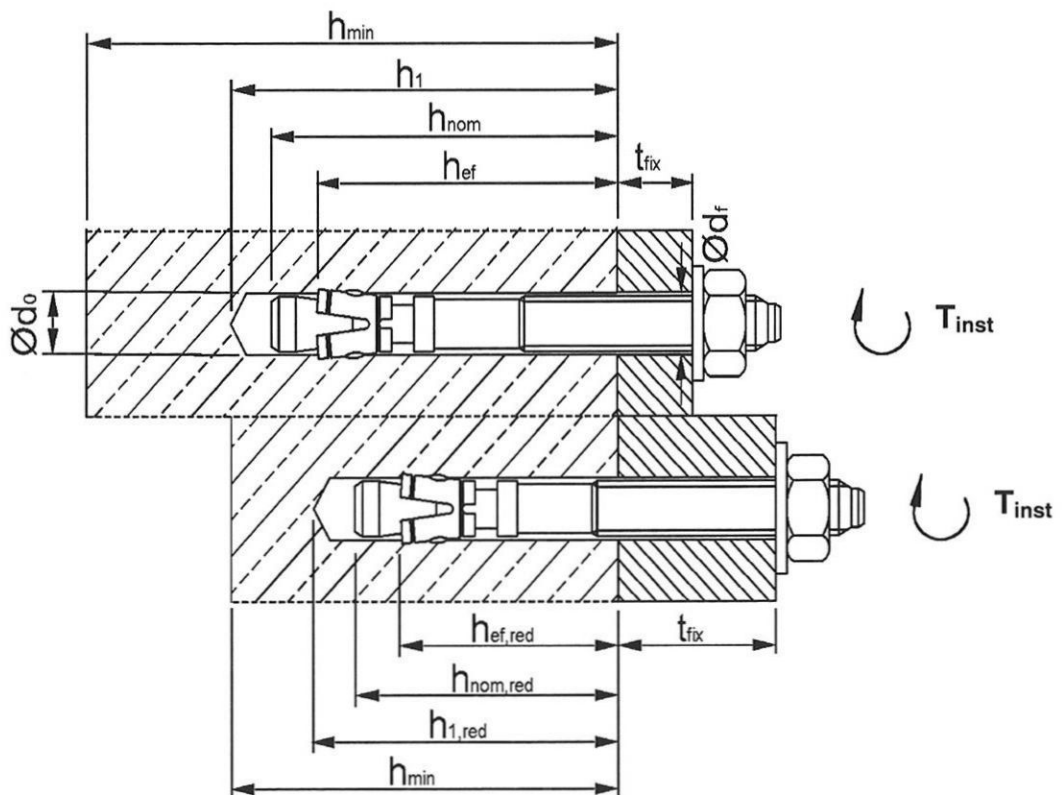
**TEAM PRO Anchor Bolt TPB****Installation data****Annex 3**of European
technical approval**ETA-11/0068**

Installation instructions

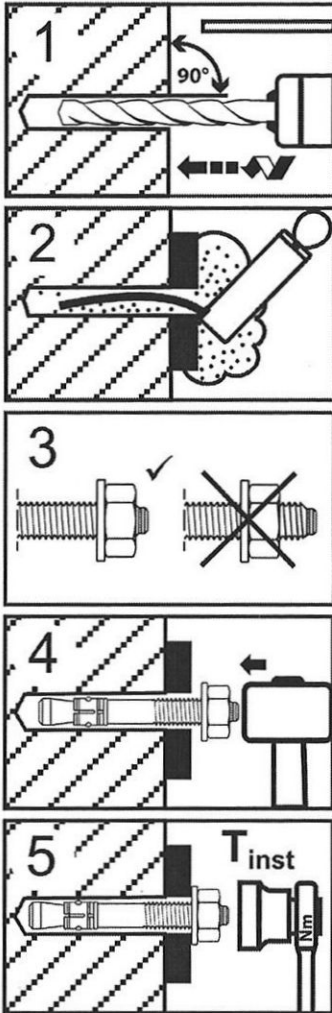

Drill hole perpendicular to concrete surface.

Blow out dust.

Check position of nut.

Drive in anchor.

Apply installation torque T_{inst} by using torque wrench.

Table 4: Minimum thickness of concrete member, minimum spacing and minimum edge distances

Anchor size			M6	M8	M10	M12	M16	M20
Standard anchorage depth h_{ef}								
Minimum member thickness	h_{min}	[mm]	100	100	100	130	170	200
Minimum spacing	s_{min}	[mm]	35	40	55	75	90	105
Minimum edge distance	c_{min}	[mm]	40	45	65	90	105	125
Reduced anchorage depth $h_{ef,red}$								
Minimum member thickness	h_{min}	[mm]	80	80	100	100	130	160
Minimum spacing	s_{min}	[mm]	35	40	55	100	100	140
Minimum edge distance	c_{min}	[mm]	40	45	65	100	100	140

TEAM PRO Anchor Bolt TPB

**Installation instructions,
Minimum member thickness, minimum spacing
and minimum edge distance**

Annex 4

of European
technical approval

ETA-11/0068

Table 5: Design method A, Characteristic values for tension loads

Anchor size			M6	M8	M10	M12	M16	M20
Steel failure								
Characteristic resistance	$N_{Rk,s}$	[kN]	8.7	15.3	26	35	65	107
Partial safety factor	γ_{Ms} ¹⁾	[-]	1.5				1.6	
Pull-out for standard anchorage depth h_{ef}								
Characteristic resistance in non-cracked concrete C20/25	$N_{Rk,p}$	[kN]	9	12	16	3)	3)	3)
Pull-out for reduced anchorage depth $h_{ef,red}$								
Characteristic resistance in non-cracked concrete C20/25	$N_{Rk,p}$	[kN]	6 ⁴⁾	3) 4)	3)	3)	3)	3)
Increasing factors for $N_{Rk,p}$	ψ_C	C30/37	[-]	1.22				
		C40/50	[-]	1.41				
		C50/60	[-]	1.55				
Concrete cone failure for standard anchorage depth h_{ef}								
Effective anchorage depth	$h_{ef} \geq$	[mm]	40	44	48	65	82	100
Spacing	$s_{cr,N}$	[mm]	3 h_{ef}					
Edge distance	$c_{cr,N}$	[mm]	1.5 h_{ef}					
Concrete cone failure for reduced anchorage depth $h_{ef,red}$								
Effective anchorage depth	$h_{ef,red} \geq$	[mm]	30 ⁴⁾	35 ⁴⁾	42	50	64	78
Spacing	$s_{cr,N}$	[mm]	3 $h_{ef,red}$					
Edge distance	$c_{cr,N}$	[mm]	1.5 $h_{ef,red}$					
Splitting for standard anchorage depth h_{ef}								
Spacing	$s_{cr,sp}$	[mm]	160	220	240	330	410	500
Edge distance	$c_{cr,sp}$	[mm]	80	110	120	165	205	250
Splitting for reduced anchorage depth $h_{ef,red}$								
Spacing	$s_{cr,sp}$	[mm]	180	210	230	240	320	400
Edge distance	$c_{cr,sp}$	[mm]	90	105	115	120	160	200
Partial safety factor	$\gamma_{Mp} = \gamma_{Mc} = \gamma_{Msp}$ ¹⁾	[-]	1.5 ²⁾					

1) In absence of other national regulations

2) The partial safety factor $\gamma_2 = 1.0$ is included

3) Pull-out failure is not decisive

4) Use restricted to anchorages of indeterminate structural components

Table 6: Displacements under tension loads

Anchor size			M6	M8	M10	M12	M16	M20
Standard anchorage depth								
Tension load	N	[kN]	4.3	5.8	7.6	11.9	16.7	23.8
Displacement	δ_{N0}	[mm]	0.4	0.5				
	$\delta_{N\infty}$	[mm]	0.7	2.3				
Reduced anchorage depth								
Tension load	N	[kN]	2.9	5.0	6.5	8.5	12.3	16.6
Displacement	δ_{N0}	[mm]	0.3	0.4				
	$\delta_{N\infty}$	[mm]	0.6	1.8				

TEAM PRO Anchor Bolt TPB**Design method A,
Characteristic values for tension loads,
Displacements****Annex 5**of European
technical approval**ETA-11/0068**

Table 7: Design method A, Characteristic values for shear loads

Anchor size		M6	M8	M10	M12	M16	M20	
Steel failure without lever arm								
Characteristic resistance	$V_{Rk,s}$	[kN]	5	11	17	25	44	69
Partial safety factor	$\gamma_{Ms}^{1)}$	[-]	1.25			1.33		
Steel failure with lever arm								
Characteristic resistance	$M_{Rk,s}^0$	[Nm]	9	23	45	78	186	363
Partial safety factor	$\gamma_{Ms}^{1)}$	[-]	1.25			1.33		
Concrete pryout failure for standard anchorage depth h_{ef}								
Factor in equation (5.6) of ETAG 001, Annex C, 5.2.3.3	k	[-]	1.0	1.0	1.0	2.0	2.0	2.0
Concrete pryout failure for reduced anchorage depth $h_{ef,red}$								
Factor in equation (5.6) of ETAG 001, Annex C, 5.2.3.3	k	[-]	1.0 ³⁾	1.0 ³⁾	1.0	1.0	2.0	2.0
Partial safety factor	$\gamma_{Mcp}^{1)}$	[-]	1.5 ²⁾					
Concrete edge failure for standard anchorage depth h_{ef}								
Effective length of anchor in shear loading	l_f	[mm]	40	44	48	65	82	100
Concrete edge failure for standard anchorage depth $h_{ef,red}$								
Effective length of anchor in shear loading	l_f	[mm]	30 ³⁾	35 ³⁾	42	50	64	78
Diameter of anchor	d_{nom}	[mm]	6	8	10	12	16	20
Partial safety factor	$\gamma_{Mc}^{1)}$	[-]	1.5 ²⁾					

¹⁾ In absence of other national regulations

²⁾ The partial safety factor $\gamma_2 = 1.0$ is included

³⁾ Use restricted to anchorages of indeterminate structural components

Table 8: Displacements under shear loads

Anchor size		M6	M8	M10	M12	M16	M20	
Shear load	V	[kN]	2.9	6.3	9.7	14.3	23.6	37.0
Displacements	δ_{V0}	[mm]	1.2	1.5	1.6	2.6	3.1	4.4
	$\delta_{V\infty}$	[mm]	2.4	2.2	2.4	3.9	4.6	6.6

TEAM PRO Anchor Bolt TPB

**Design method A,
Characteristic values for shear loads,
Displacements**

Annex 6

of European
technical approval

ETA-11/0068