



European Technical Approval ETA-08/0146

English translation prepared by DIBt - Original version in German language

Handelsbezeichnung
Trade name

Ruberstein Wärmedämm-Verbundsystem
Ruberstein-ETICS

Zulassungsinhaber
Holder of approval

RUBERSTEINWERK GmbH
Baustoffe für Mauerwerk und Fassade
Michelner Straße 7-9
09350 Lichtenstein
DEUTSCHLAND

Zulassungsgegenstand
und Verwendungszweck
*Generic type and use
of construction product*

Außenseitiges Wärmedämm-Verbundsystem mit Putzschicht zur
Wärmedämmung von Gebäuden
*External Thermal Insulation Composite System with rendering for the
use as external insulation of building walls*

Geltungsdauer:
Validity: vom
from
bis
to

6 May 2013
6 May 2018

Herstellwerk
Manufacturing plant

RUBERSTEINWERK GmbH
Baustoffe für Mauerwerk und Fassade
Michelner Straße 7-9
09350 Lichtenstein
DEUTSCHLAND

Diese Zulassung umfasst
This Approval contains

18 Seiten einschließlich 1 Anhang
18 pages including 1 annex

Diese Zulassung ersetzt
This Approval replaces

ETA-08/0146 mit Geltungsdauer vom 14.07.2008 bis 13.07.2013
ETA-08/0146 with validity from 14.07.2008 to 13.07.2013

I LEGAL BASES AND GENERAL CONDITIONS

- 1 This European technical approval is issued by Deutsches Institut für Bautechnik in accordance with:
 - Council Directive 89/106/EEC of 21 December 1988 on the approximation of laws, regulations and administrative provisions of Member States relating to construction products¹, modified by Council Directive 93/68/EEC² and Regulation (EC) N° 1882/2003 of the European Parliament and of the Council³;
 - *Gesetz über das In-Verkehr-Bringen von und den freien Warenverkehr mit Bauprodukten zur Umsetzung der Richtlinie 89/106/EWG des Rates vom 21. Dezember 1988 zur Angleichung der Rechts- und Verwaltungsvorschriften der Mitgliedstaaten über Bauprodukte und anderer Rechtsakte der Europäischen Gemeinschaften (Bauproduktengesetz - BauPG) vom 28. April 1998⁴, as amended by Article 2 of the law of 8 November 2011⁵;*
 - Common Procedural Rules for Requesting, Preparing and the Granting of European technical approvals set out in the Annex to Commission Decision 94/23/EC⁶;
 - Guideline for European technical approval of "External Thermal Insulation Composite Systems with Rendering", ETAG 004, edition March 2000.
- 2 Deutsches Institut für Bautechnik is authorized to check whether the provisions of this European technical approval are met. Checking may take place in the manufacturing plant. Nevertheless, the responsibility for the conformity of the products to the European technical approval and for their fitness for the intended use remains with the holder of the European technical approval.
- 3 This European technical approval is not to be transferred to manufacturers or agents of manufacturers other than those indicated on page 1, or manufacturing plants other than those laid down in the context of this European technical approval.
- 4 This European technical approval may be withdrawn by Deutsches Institut für Bautechnik, in particular pursuant to information by the Commission according to Article 5 (1) of Council Directive 89/106/EEC.
- 5 Reproduction of this European technical approval including transmission by electronic means shall be in full. However, partial reproduction can be made with the written consent of Deutsches Institut für Bautechnik. In this case partial reproduction has to be designated as such. Texts and drawings of advertising brochures shall not contradict or misuse the European technical approval.
- 6 The European technical approval is issued by the approval body in its official language. This version corresponds fully to the version circulated within EOTA. Translations into other languages have to be designated as such.

¹ Official Journal of the European Communities L 40, 11 February 1989, p. 12
² Official Journal of the European Communities L 220, 30 August 1993, p. 1
³ Official Journal of the European Union L 284, 31 October 2003, p. 25
⁴ *Bundesgesetzblatt Teil I 1998*, p. 812
⁵ *Bundesgesetzblatt Teil I 2011*, p. 2178
⁶ Official Journal of the European Communities L 17, 20 January 1994, p. 34

II SPECIFIC CONDITIONS OF THE EUROPEAN TECHNICAL APPROVAL

1 Definition of products and intended use

The External Thermal Insulation Composite System "Ruberstein Wärmedämm-Verbundsystem" called ETICS in the following text, is designed and installed in accordance with the ETA-holder's design and installation instructions, deposited with the Deutsches Institut für Bautechnik (DIBt). The ETICS comprises the following components, which are factory-produced by the ETA-holder or a supplier. It's made up on site from these. The ETA-holder is ultimately responsible for the ETICS.

1.1 Definition of the construction product

	Components (see clause 2.3 for further description, characteristics and performances)	Coverage [kg/m ²]	Thickness [mm]
Insulation material with associated method of fixing	Bonded ETICS: <ul style="list-style-type: none"> • Insulation product factory-prefabricated expanded polystyrene (EPS) to EN 13163:2008 <ul style="list-style-type: none"> - standard EPS • Adhesives <ul style="list-style-type: none"> - Ruberstein Trockenspachtel grau (cement based powder requiring addition of about 20 - 24 % of water) - Ruberstein Trockenspachtel weiß (cement based powder requiring addition of about 20 - 24 % of water) 	<p>–</p> <p>2.0 – 5.0 (prepared)</p> <p>2.0 – 5.0 (prepared)</p>	<p>≤ 400</p> <p>–</p> <p>–</p>
	Mechanically fixed ETICS with profiles and supplementary adhesive: <ul style="list-style-type: none"> • Insulation product factory-prefabricated expanded polystyrene (EPS) to EN 13163:2008 <ul style="list-style-type: none"> - standard EPS • Supplementary adhesive (equal to bonded ETICS) • Profiles <ul style="list-style-type: none"> - "Ruberstein Halteleiste" and - "Ruberstein Verbindungsleiste" Polyvinyl chloride (PVC) profiles	<p>–</p>	<p>60 to 200</p>

	Components (see clause 2.3 for further description, characteristics and performances)	Coverage [kg/m ²]	Thickness [mm]
Insulation material with associated method of fixing	<ul style="list-style-type: none"> • Anchors for profiles <ul style="list-style-type: none"> - ejothem SK U - WS 8 L - WS 8 N - ejothem SDK U - IsoFux ND-8Z - SDF-K plus, SDF-S plus - ejothem NK U 		
	<p>Mechanically fixed ETICS with anchors and supplementary adhesive:</p> <ul style="list-style-type: none"> • Insulation product factory-prefabricated expanded polystyrene (EPS) to EN 13163:2008 <ul style="list-style-type: none"> - standard EPS • Supplementary adhesive (equal to bonded ETICS) • Anchors for insulation product all anchors with ETA according to ETAG 014⁷ with characteristics defined in clause 2.3.2 	-	60 to 400
Base coat	<p>Ruberstein Trockenspachtel grau Ruberstein Trockenspachtel weiß Cement based powder with additional redispersible synthetic-resin and aggregates requiring addition of 20 - 24 % of water. Identical with the equally named adhesives given above.</p>	about 4.0 (powder)	about 4.0
Glass fibre mesh	<p>Ruberstein Glasgittergewebe Alkali- and slide-resistant glass fibre mesh with mass per unit area of about 160 g/m² and mesh size of about 4 mm x 4 mm.</p>	-	-
Key coat	<p>Ruberstein Putzgrund Ready to use pigmented acrylic-resin dispersion liquid. To be used with the finishing coat "Ruberstein Organischer Strukturputz" indicated hereafter.</p> <p>Ruberstein Universalputzgrund Ready to use pigmented acrylic-resin dispersion liquid. To be used with all finishing coats indicated hereafter.</p>	} about 0.2	-

⁷

ETAG 014

Plastic anchors for fixing of external thermal insulation composite systems with rendering

	Components (see clause 2.3 for further description, characteristics and performances)	Coverage [kg/m ²]	Thickness [mm]
Finishing coat	<p>To use with a key coat indicated above:</p> <ul style="list-style-type: none"> Ready to use pastes – acrylic binder: Ruberstein Organischer Strukturputz Kratzputz: particle size 2 – 2.5 – 3 and 4 mm Reibeputz: particle size 2 – 3 and 4 mm Ready to use pastes – acrylic/siloxane binder: Ruberstein Siliconharzputz Kratzputz: particle size 2 – 2.5 – 3 and 4 mm Reibeputz: particle size 2 – 3 and 4 mm Ready to use paste – acrylic/silicate binder: Ruberstein Silikatputz Kratzputz: particle size 2 – 2.5 – 3 and 4 mm Reibeputz: particle size 2 – 3 and 4 mm Thin layered cement based powder requiring addition of about 22 % of water: Ruberstein Mineralischer Strukturputz Kratzputz: particle size 1.5 – 3 and 5 mm Reibeputz: particle size 2 – 3 and 5 mm 	<p>3.0 – 6.0 3.0 – 5.5 (prepared)</p> <p>2.7 – 4.5 3.0 – 5.5 (prepared)</p> <p>2.7 – 4.5 3.0 – 5.5 (prepared)</p> <p>3.0 – 7.5 3.0 – 7.5 (powder)</p>	Regulated by particle size
Ancillary material	Description in accordance with clause 3.2.2.5 of ETAG 004 and decorative coatings compatible with the ETICS to be applied to the finishing coat. Remains the responsibility of the ETA-holder.		

1.2 Intended use

This ETICS is intended to be used as external insulation to the walls of buildings made of masonry (bricks, blocks, stones ...) or concrete (cast on site or as prefabricated panels) with and without rendering (Class A1 or A2 - s1,d0 according to EN 13501-1:2007). It shall be designed to give the wall to which it is applied satisfactory thermal insulation.

The ETICS is non load-bearing construction element. It does not contribute directly to the stability of the wall on which it is installed, but it can contribute to durability by providing enhanced protection from the effects of weathering.

The ETICS can be used on new or existing (retrofit) vertical walls.

The ETICS is not intended to ensure the air tightness of the building structure.

The choice of the method of fixing depends on the characteristics of the substrate, which could need preparation (see clause 7.2.1 of ETAG 004) and on the national instructions.

The provisions made in this European technical approval (ETA) based upon the assumed intended working life of the ETICS of at least 25 years, provided that the conditions laid down in clauses 4.2, 5.1 and 5.2 for the packaging, transport, storage, installation as well as appropriate use, maintenance and repair are met. The indications given on the working life cannot be interpreted as a guarantee given by the manufacturer or the Approval Body, but should only be regarded as a means to choosing the appropriate products in relation to the expected, economically reasonable working life of the works.

2 Characteristics of products and methods of verification

2.1 General

The assessment of the fitness for use of the ETICS for the intended use according to the Essential Requirements was carried out in compliance with ETAG 004, "Guideline for European Technical Approval of External Thermal Insulation Composite Systems with rendering", edition March 2000 (called ETAG 004 in this ETA).

Characteristics (of the components as well as of the ETICS), not mentioned in this ETA nor in the annex shall correspond to the respective values laid down in the technical documentation of this ETA.

2.2 Characteristics of the ETICS

2.2.1 Reaction to fire

Rendering system: Base coat with finishing coat and compatible key coat	Maximum declared organic content	Class according to EN 13501-1:2007
All configurations	Base coat ≤ 3.2 % Finishing coat ≤ 7.1 %	B - s2,d0

Mounting and fixing

(for all end use applications given in clause 1.2 of the ETA)

The assessment of reaction to fire is based on tests with a maximum insulation layer thickness of 180 mm (testing according to EN 13823:2002 – SBI-test), resp. 60 mm (testing according to EN ISO 11925-2:2002) and a maximum insulation material (EPS) density of 25 kg/m³ as well as rendering systems with two different types of binder (inorganic and organic) each with the highest organic content and the lowest amount of flame retardant and additives.

The manufacturer of the tested EPS is Karl Bachl GmbH & Co. KG. EPS with higher density than tested or with other chemical composition or of an other manufacturer, which fulfils the requirements of clause 2.3.1 and is deposited with the DIBt, can be used if it fulfils the requirements of Class E according to EN 13501-1:2007 by testing specimens with a thickness of 10 mm and with the highest possible density.

For rendering systems with inorganic finishing coats the assessment of reaction to fire is based on tests with a silicate based finishing coat with the mean thickness of 3 mm.

For rendering systems with organic based finishing coats the assessment of reaction to fire is based on tests with an acrylic based finishing coat with the mean thickness of 3 mm.

For the SBI-test the ETICS was mounted directly to a calcium silicate substrate (class A2 - s1,d0) according to EN 13238:2001 with a thickness of 11 mm.

For testing according to EN ISO 11925-2:2002 no substrate was used.

The installation of the ETICS was carried out by the approval holder following his design and installation instructions using a single mesh all over the test specimen.

The tests specimens were prefabricated and did not include any joints.

For the SBI-test the lateral edges were covered with the rendering system.

For testing according to EN ISO 11925-2:2002 the edges were not covered with the rendering system (cut edges). The tests were performed with surface flaming of the front side and edge flaming turned by 90°.

Anchors were not included in the tested ETICS as they have no influence on the test result.

Note:

A European reference fire scenario for facades has not been laid down. In some Member States, the classification of ETICS according to EN 13501-1 might not be sufficient for the use in facades. An additional assessment of ETICS according to national provisions (e. g. on the basis of a large scale test) might be necessary to comply with Member State regulations, until the existing European classification system has been completed.

2.2.2 Water absorption (capillarity test)

Base coat	Water absorption after 1 h < 1 kg/m ²	Water absorption after 24 h < 0.5 kg/m ²
Ruberstein Trockenspachtel grau	x	x
Ruberstein Trockenspachtel weiß	x	x

Rendering system: Base coat with finishing coat and compatible key coat indicated hereafter	Water absorption after 24 h	
	< 0.5 kg/m ²	≥ 0.5 kg/m ²
Ruberstein Organischer Strukturputz + Ruberstein Putzgrund		x
Ruberstein Organischer Strukturputz + Ruberstein Universalputzgrund	x	
Ruberstein Siliconharzputz + Ruberstein Universalputzgrund		x
Ruberstein Silikatputz + Ruberstein Universalputzgrund		x
Ruberstein Mineralischer Strukturputz + Ruberstein Universalputzgrund	x	

2.2.3 Hygrothermal behaviour

Hygrothermal cycles tests have not been performed (see clause 2.2.10).

2.2.4 Freeze/thaw behaviour

The water absorption of both base coats as well as the rendering system with finishing coats and compatible key coats "Ruberstein Organischer Strukturputz" + "Ruberstein Universalputzgrund" and "Ruberstein Mineralischer Strukturputz" + "Ruberstein Universalputzgrund" is less than 0.5 kg/m² after 24 hours. These configurations of the ETICS are so assessed as freeze/thaw resistant.

The ETICS with finishing coats and compatible key coats "Ruberstein Organischer Strukturputz" + "Ruberstein Putzgrund", "Ruberstein Siliconharzputz" + "Ruberstein Universalputzgrund" and "Ruberstein Silikatputz" + "Ruberstein Universalputzgrund" has been assessed as freeze/thaw resistant according to the simulated method.

2.2.5 Impact resistance

The verified resistance to hard body impact results in the classification into categories listed below. The resistance to perforation has not to be verified, because of a total render thickness of not less than 6 mm.

Rendering system: Base coat with finishing coat indicated hereafter and compatible key coat	Single mesh "Ruberstein Glasgittergewebe"
Ruberstein Organischer Strukturputz	Category I
Ruberstein Siliconharzputz	Category I
Ruberstein Silikatputz	Category I
Ruberstein Mineralischer Strukturputz	Category II

2.2.6 Water vapour permeability

Rendering system: Base coat with finishing coat indicated hereafter and compatible key coat	Equivalent air thickness $s_{D,B}$
Ruberstein Organischer Strukturputz	≤ 1.0 m (Test result obtained with base coat "Trockenspachtel weiß", key coat "Putzgrund" and finishing coat "Organischer Kratzputz", particle size 4 mm: 0.7 m)
Ruberstein Siliconharzputz	≤ 1.0 m (Test result obtained with base coat "Trockenspachtel weiß", key coat "Universal-Putzgrund" and finishing coat "Siliconharz Kratzputz", particle size 4 mm: 0.3 m)
Ruberstein Silikatputz	≤ 1.0 m (Test result obtained with base coat "Trockenspachtel weiß", key coat "Universal-Putzgrund" and finishing coat "Silikat Kratzputz", particle size 4 mm : 0.2 m)
Ruberstein Mineralischer Strukturputz	≤ 1.0 m (Test result obtained with base coat "Trockenspachtel weiß", key coat "Putzgrund" and finishing coat "Mineralischer Scheibenputz", particle size 5 mm : 0.2 m)

2.2.7 Emission of dangerous substances or radiation

The ETICS complies with the provisions of Guidance Paper H ("A harmonized approach related to dangerous substances under the construction product directives Revision August 2002").

In addition to the specific clauses relating to dangerous substances contained in this ETA, there may be other requirements applicable to the products falling within its scope (e. g. transposed European legislation and national laws, regulations and administrative provisions). In order to meet the provisions of the Construction Products Directive, these requirements need also to be complied with, when and where they apply.

2.2.8 Safety in use

2.2.8.1 Bond strengths

Bond strength between base coat and insulation product (EPS)

Base coat	Conditioning		
	Initial state	After hygrothermal cycles on the rig ^f	After freeze/thaw test
Ruberstein Trockenspachtel grau	≥ 0.08 MPa	≥ 0.08 MPa	≥ 0.08 MPa
Ruberstein Trockenspachtel weiß	≥ 0.08 MPa	≥ 0.08 MPa	≥ 0.08 MPa

Bond strength between adhesive and substrate resp. insulation product (EPS)

Adhesive	Substrate resp. insulation product	Conditioning		
		Initial state	2 d immersion in water + 2 h drying	2 d immersion in water + 7 d drying
Ruberstein Trockenspachtel grau	Concrete	≥ 0.25 MPa	≥ 0.08 MPa	≥ 0.25 MPa
	EPS	≥ 0.08 MPa	≥ 0.03 MPa	≥ 0.08 MPa
Ruberstein Trockenspachtel grau	Concrete	≥ 0.25 MPa	≥ 0.08 MPa	≥ 0.25 MPa
	EPS	≥ 0.08 MPa	≥ 0.03 MPa	≥ 0.08 MPa

Bonded surface:

For bonded ETICS the calculated minimal bonded surface area, according to ETAG 004, clause 6.1.4.1.3 is 40 %.

2.2.8.2 Fixing strength (displacement test)

Test not required because the ETICS fulfils the following criteria to clause 5.1.4.2 of ETAG 004:

- the bonded area exceeds 20 %
- $E \cdot d < 50\,000 \text{ N/mm}$
(E: modulus of elasticity of the base coat – d: mean dried thickness of the base coat)

2.2.8.3 Wind load resistance

Safety in use of mechanically fixed ETICS using profiles

The following failure loads only apply to the listed combination (EPS panel's characteristics)/ (way of fixing the profiles) and the characteristics of the insulation product given in clause 2.3.1.

Characteristics of the EPS (standard EPS)	Dimensions	500 mm x 500 mm
	Thickness	≥ 60 mm
	Tensile strength perpendicular to the faces	≥ 150 kPa
	Shear modulus	≥ 1.0 N/mm ²
Failure loads [N/panel] (Static Foam Block Test)	Horizontal profiles fixed every 30 cm and 49.4 cm long vertical connection profiles	Minimal: 950 Average: 1010

⁸

According to the EOTA GD 004 existing data was used after EOTA consensus has been reached that the deviations of the test methods use from the EOTA test methods are not relevant or the results are on the safe side.

Safety in use of mechanically fixed ETICS using anchors

The following failure loads only apply to the listed combination (EPS panel's characteristics)/ (anchor plate's characteristics) and the characteristics of the insulation product given in clause 2.3.1.

Apply to all anchors listed in the Table in clause 1.1 mounted on the insulation panels surface				
Characteristics of the EPS (standard EPS)	Thickness		≥ 60 mm	
	Tensile strength perpendicular to the faces		≥ 100 kPa	
	Shear modulus		≥ 1.0 N/mm ²	
Plate diameter of anchor			Ø 60 mm	Ø 90 mm
Failure loads [N]	Anchors not placed at the panel joints (Static Foam Block Test)	R _{panel}	Minimal: 510 Average: 520	Minimal: 720 Average: 730
	Anchors placed at the panel joints (Pull-through test)	R _{joint}	Minimal: 400 Average: 430	Minimal: 430 Average: 470

The failure loads specified above only apply to the following anchors with a plate diameter of anchor of 60 mm with deep mounting under the following conditions of installation:

Anchor	Thickness of the EPS [d]	Conditions of installation*
ejotherm STR U ejotherm STR U 2G (ETA-04/0023)	100 mm > d ≥ 80 mm	– Maximum installation depth of the anchor plate: 15 mm (≙ thickness of insulation cover) – Maximum depth of die: 5 mm
	≥ 100 mm	– Maximum installation depth of the anchor plate: 15 mm (≙ thickness of insulation cover) – Maximum depth of die: 20 mm
IsoFux NDT8LZ (ETA-05/0080)	≥ 80 mm	– Maximum depth of countersink: 20 mm
TERMOZ 8 SV (ETA-06/0180)	≥ 80 mm	– Maximum installation depth of the anchor plate: 15 mm (≙ thickness of insulation cover)

* According to the appropriate ETA of anchor

The wind load resistance R_d of the ETICS is calculated as follows:

$$R_{dB} = \frac{R_{panel} \cdot n_{panel} + R_{joint} \cdot n_{joint}}{\gamma}$$

n_{panel}: number (per m²) of anchors not placed at the panel joints

n_{joint}: number (per m²) of anchors placed at the panel joint

γ: national safety factor

2.2.9 Thermal resistance

The nominal value of the additional thermal resistance R provided by the ETICS to the substrate wall is calculated in accordance with EN ISO 6946:2007 from the nominal value of the insulation product's thermal resistance R_D given accompanied to the CE marking and from the thermal resistance of the rendering system R_{render} which is about 0.02 (m²·K)/W.

$$R = R_D + R_{render}$$

The thermal bridges caused by anchors increase the thermal transmittance U . This influence had to take into account according to EN ISO 6946:2007X

$$U_c = U + \chi_p \cdot n$$

corrected thermal transmittance

where: $\chi_p \cdot n$ influence of thermal bridges

n number of anchors per m^2

χ_p local influence of thermal bridge caused by an anchor. The values listed below can be taken into account, if not specified in the anchor's technical approval

$\chi_p = 0.004 \text{ W/K}$ for anchors with a galvanized steel screw with the head covered by a plastic material

$\chi_p = 0.002 \text{ W/K}$ for anchors with a stainless steel screw with the head covered by plastic material, and for anchors with an air gap at the head of the screw

The thermal bridges caused by PVC profiles are negligible.

2.2.10 Aspects of durability and serviceability

2.2.10.1 Experience on site of the ETICS

An extensive experience on site has been assessed by the DIBt in Germany.

2.2.10.2 Bond strength after ageing

In addition to the testing indicated below the rendering system (base coats with each finishing coat indicated in the Table in clause 1.1) has proofed its bond strength after ageing by experience on site.

Rendering system: Base coat with finishing coat and compatible key coat indicated hereafter	Ruberstein Organischer Strukturputz + Ruberstein Putzgrund	$\geq 0.08 \text{ MPa}$
	Ruberstein Siliconharzputz + Ruberstein Universalputzgrund	
	Ruberstein Silikatputz + Ruberstein Universalputzgrund	
	Ruberstein Mineralischer Strukturputz + Ruberstein Universalputzgrund	

2.3 Characteristics of the components

Detailed information on the chemical composition and other identifying characteristics of the components, following Annex C of ETAG 004 have been deposited with the DIBt.

Further information can be observed from the product data sheets, which are part of the technical documentation for this ETA.

2.3.1 Thermal insulation product

Factory-prefabricated, uncoated panels made of expanded polystyrene (EPS) to EN 13163:2008 shall be used, having the description and characteristics defined in the Table below.

Description and characteristics	For bonded ETICS	For mechanically fixed ETICS	
		with anchors and supplementary adhesive	with profiles and supplementary adhesive
Reaction to fire; EN 13501-1:2007	Class E*		
Thermal resistance [(m ² ·K)/W]	Defined in the CE marking in reference to EN 13163:2008		
Tolerances			
Length; EN 822:1994	± 2 (class L2)		
Width [mm]; EN 822:1994	± 2 (class W2)		
Thickness [mm]; EN 823:1994	± 1 (class T2)		
Squareness [mm/m]; EN 824:1994	± 2 (class S2)		
Flatness [mm/m]; EN 825:1994	5 (class P4)		
Dimensional stability under			
- laboratory conditions [%]; EN 1603:1996	± 0.2 (class DS(N)2)		
- specified temperature and humidity conditions [%]; EN 1604:1996	2 (level DS(70,-)2 or level DS(70,-)1)		
Water absorption (long term partial immersion) [kg/m ²]; EN 12087:1997	W _{ip} ≤ 0.5		
Water vapour diffusion resistance factor; EN 12086:1997	μ = 20 – 50		
Tensile strength perpendicular to the faces in dry conditions** [kPa]; EN 1607:1996 - standard EPS	σ _{mt} ≥ 80	σ _{mt} ≥ 100	σ _{mt} ≥ 150
Bending strength** [kPa]; EN 12089:1997	σ _b ≥ 50		
Apparent density [kg/m ³]; EN 1602:1996	ρ _a ≤ 20		
Shear strength** [kPa]; EN 12090:1997	20 ≤ f _{tk} ≤ 100		
Shear modulus [MPa]; EN 12090:1997 - standard EPS	1.0 ≤ G _m ≤ 2.0		
Testing of characteristics see EN 13163:2008.			
* See the conditions of clause 2.2.1 for the EPS.			
** Minimal value of all single values			

Thermal insulation materials for mechanically fixed ETICS with profiles must circumferentially at the edges, 24 mm from the inner surface, get an approx. 3 mm wide and 13 to 18 mm deep groove cut-in at the factory.

2.3.2 Anchors

All anchors with ETA according to ETAG 014⁷ with characteristics having the description below shall be used in the mechanically fixed ETICS:

- plate diameter of anchor ≥ 60 mm resp. ≥ 90 mm
- plate stiffness ≥ 0.3 kN/mm
- load resistance of the anchor plate ≥ 1.0 kN

These characteristics and the characteristic tension resistance of the anchors shall be taken from the corresponding ETA.

The anchors listed in the Table in clause 1.1 with reference to the respective ETA shall be used in the mechanically fixed ETICS with profiles for fixing the horizontal profiles.

Trade name	ETA-number
ejothem SK U	ETA-02/0018
WS 8 L	ETA-02/0019
WS 8 N	ETA-03/0019
ejothem SDK U	ETA-04/0023
IsoFux ND-8Z	ETA-04/0032
SDF-K plus, SDF-S plus	ETA-04/0064
ejothem NK U	ETA-05/0009

2.3.3 Profiles

Polyvinyl chloride (PVC) profiles, PVC-U, EGL, 082-05-T33 to EN ISO 1163-1:1999, with the measurements according to Annex 1 are to be used in the mechanically fixed ETICS with profiles.

The Pull-through resistance of fixings from profiles is ≥ 500 N.

2.3.4 Render (base coat)

The average value of crack width of the base coats reinforced with the glass fibre mesh "Ruberstein Glasgittergewebe" measured at a render strain value of 1 % is:

Base coat	Average value of crack width $w_{R(1\%)B}$
Ruberstein Trockenspachtel grau	No performance determined
Ruberstein Trockenspachtel weiß	0.10 mm

2.3.5 Reinforcement (glass fibre mesh)

Characteristics (alkali resistance): Pass

	"Ruberstein Glasgittergewebe"	
	Warp	Weft
Residual strength after ageing [N/mm]	≥ 20	≥ 20
Relative residual resistance after ageing in % of the strength in the as-delivered state	≥ 50	≥ 50

3 Evaluation and attestation of conformity and CE-marking

3.1 System of attestation of conformity

According to the decision 97/556/EC of the European Commission⁹ amended by 2001/596/EC¹⁰ system 1 or 2+ of the attestation of conformity applies depending on reaction to fire.

Considering Class B for reaction to fire of the ETICS, the systems of attestation of conformity are system 1 regarding reaction to fire characteristic and system 2+ regarding other characteristics than reaction to fire.

These systems of attestation of conformity are defined as follows:

System 1: Certification of the conformity of the product by a notified certification body on the basis of:

- (a) Tasks for the manufacturer:
 - (1) factory production control;
 - (2) further testing of samples taken at the factory by the manufacturer in accordance with a prescribed test plan.
- (b) Tasks for the notified body:
 - (3) initial type-testing of the product;
 - (4) initial inspection of factory and of factory production control;
 - (5) continuous surveillance, assessment and approval of factory production control.

System 2+: Declaration of conformity of the product by the manufacturer on the basis of:

- (a) Tasks for the manufacturer:
 - (1) initial type-testing of the product;
 - (2) factory production control;
 - (3) testing of samples taken at the factory in accordance with a prescribed test plan.
- (b) Tasks for the notified body:
 - (4) certification of factory production control on the basis of:
 - initial inspection of factory and of factory production control;
 - continuous surveillance, assessment and approval of factory production control.

3.2 Responsibilities

3.2.1 Tasks for the manufacturer

3.2.1.1 Factory production control

The manufacturer shall exercise permanent internal control of production. All the elements, requirements and provisions adopted by the manufacturer shall be documented in a systematic manner in the form of written policies and procedures, including records of results performed. This production control system shall insure that the ETICS and the components are in conformity with this ETA.

The manufacturer shall only use raw materials stated in the technical documentation of this ETA. The incoming raw materials are subjected to verifications by the manufacturer before acceptance.

⁹ Official Journal of the European Communities/Union L229/14 of 20.08.1997
¹⁰ Official Journal of the European Communities/Union L 209/33 of 2.8.2001

The factory production control shall be in accordance with the "Control plan"¹¹ which is part of the technical documentation of this ETA. The "Control plan"¹¹ has been agreed between the manufacturer and the DIBt and is laid down in the context of the factory production control system operated by the manufacturer and deposited with the DIBt.

The results of factory production control shall be recorded and evaluated in accordance with the provisions of the "Control plan"¹¹. The records include at least the following information:

- designation of the product, the basic materials and components;
- type of control or testing;
- date of manufacture of the product and date of testing of the product or basic materials or components;
- result of control and testing and, if appropriate, comparison with requirements;
- signature of person responsible for factory production control.

The records shall be presented to the notified body involved in continuous surveillance. On request they shall be presented to the DIBt.

3.2.1.2 Other tasks for the manufacturer

For initial type-testing of the ETICS and the components regarding other characteristics than reaction to fire the results of the tests performed as part of the assessment for the ETA shall be used unless there are changes in the production line or plant. In such cases the necessary initial type-testing has to be agreed with the DIBt.

The manufacturer shall, on the basis of a contract, involve a body which is notified for the tasks referred to in clause 3.1 in the field of ETICS in order to undertake the actions laid down in clause 3.2.2. For this purpose, the "Control plan"¹¹ referred to in clauses 3.2.1.1 and 3.2.2 shall be handed over by the manufacturer to the notified bodies involved.

The manufacturer shall make a declaration of conformity, stating that the ETICS is in conformity with the provisions of ETA-08/0146 issued on 6 May 2013.

3.2.2 Tasks for the notified bodies

The notified body shall perform the

- initial type-testing of the ETICS and the components regarding reaction to fire characteristic
 - initial inspection of factory and of factory production control,
 - continuous surveillance, assessment and approval of factory production control,
- in accordance with the provisions laid down in the "Control plan"¹¹.

The notified body shall retain the essential points of its actions referred to above and state the results obtained and conclusions drawn in a written report.

The notified certification body involved by the manufacturer shall issue an EC certificate of conformity of the ETICS which includes the certification of factory production control stating the conformity with the provisions of this ETA.

In cases where the provisions of the ETA and its "Control plan"¹¹ are no longer fulfilled the notified certification body shall withdraw the certificate of conformity and inform the DIBt without delay.

¹¹ The "Control plan" is a confidential part of the European technical approval and only handed over to the notified body involved in the procedure of attestation of conformity. See section 3.2.2.

3.3 Marking

3.3.1 CE marking

The CE marking shall be affixed on the accompanying commercial document. The letters "CE" shall be followed by the identification number of the notified certification body and be accompanied by the following additional information:

- the name and address of the ETA-holder (legal entity responsible for the manufacture),
- the last two digits of the year in which the CE marking was affixed,
- the number of the EC certificate of conformity for the ETICS,
- the number of the ETA,
- the number of the ETAG,
- the ETICS trade name.

3.3.2 Additional marking

The respective trade name of the individual components of the ETICS shall be given on the packaging.

In addition to the trade name the following information shall be given in the accompanying commercial document and/or on the packaging of the thermal insulation product:

- minimum value of the tensile strength perpendicular to the faces of the insulation product,
- shear modulus of the insulation product.

4 Assumptions under which the fitness of the product for the intended use was favourably assessed

4.1 Manufacturing

The composition and manufacturing process used for the components of the ETICS shall comply with those on which the approval tests were based. Composition and manufacturing process are deposited at the DIBt.

The ETA is issued for the ETICS on the basis of agreed data/information, deposited with the DIBt, which identifies the ETICS that has been assessed and judged. Changes to the ETICS or the components or their production process, which could result in this deposited data/information being incorrect, should be notified to the DIBt before the changes are introduced. DIBt will decide whether or not such changes affect the approval and consequently the validity of the CE marking on the basis of the approval and if so whether further assessment or alterations to the approval shall be necessary.

4.2 Installation, design and execution

4.2.1 General

The wall on which the ETICS is applied shall be sufficiently stable and airtight. Its stiffness shall be large enough to ensure that the ETICS is not subjected to deformations, which could lead to damage.

The requirements given in ETAG 004, chapter 7, have to be considered.

4.2.2 Installation

The ETICS is installed on site. The approval holder is obliged to instruct all those entrusted with the design and execution of the ETICS about the specific conditions of this ETA and all other details necessary for perfect execution.

Only the components whose trade name is given in clause 1.1 and which have the characteristics according to clause 2.3 may be used for the ETICS.

4.2.3 Design

4.2.3.1 Requirements for the substrate

As to the requirements for the substrate and its preparation, ETAG 004, clause 7.2.1 applies.

The substrate for mechanically fixed systems should have a sufficient resistance for the use of anchors according to clause 2.3.2. The conditions of the ETA for the anchor concerned apply.

4.2.3.2 Resistance to wind load

Judging of sufficient resistance to wind load should be on the basis of the resistance of the fixings according to clause 2.2.8.3 and of the characteristic tension resistance of the used anchor according to clause 2.3.2. Taking into account the national safety factors the design values of resistance are determined. The smaller one of the design resistances of the ETICS (R_d) and of the anchor (N_{Rd}) is decisive.

The determined design wind load suction S_d (taking into account the national safety factors) is compared with the design resistance.

4.2.4 Execution

The manufacturer's design and installation instructions, which are part of the technical documentation for this ETA, shall be observed with respect to the installation of the ETICS and drying times of rendering products.

5 Indications to the manufacturer

5.1 Packaging, transport and storage

Packaging of the components has to be such that they are protected against moisture during transport and storage, unless other measures are foreseen by the manufacturer for this purpose.

The components are to be protected against damage.

5.2 Use, maintenance, repair

To the indications on use, maintenance and repair ETAG 004, clause 7.3 applies.

Dirk Brandenburger
Head of Department

beglaubigt:
Wachner

Horizontal profile – "Ruberstein Halteleise" (dimensions in millimetres)

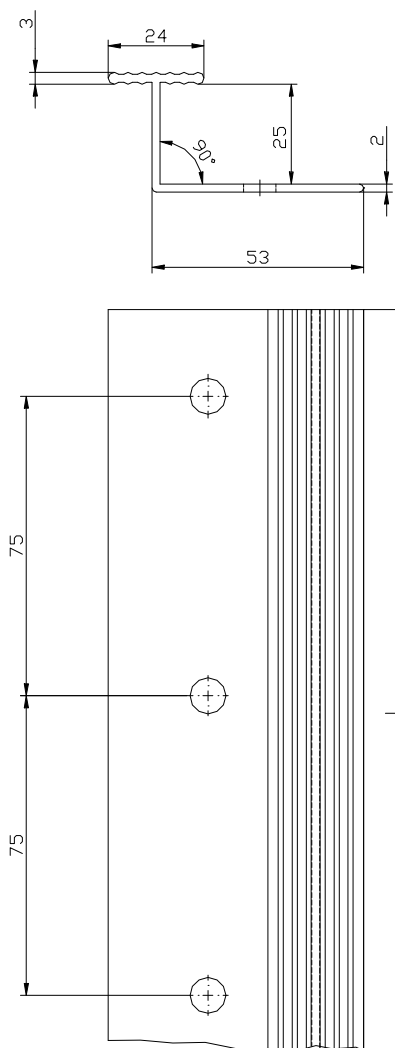

Vertical connection profile "Ruberstein Verbindungsleiste" (dimensions in millimetres)

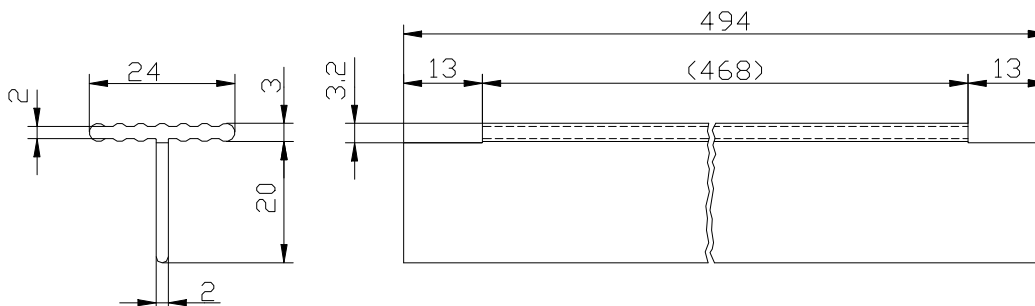

ETICS "Ruberstein Wärmedämm-Verbundsystem"

Horizontal and vertical PVC profiles

Annex 1