



## European Technical Approval ETA-13/0910

English translation prepared by DIBt – Original version in German language

Handelsbezeichnung  
*Trade name*

"System Curaflam Manschette ECO Pro" bzw. "System FS-M R2"  
"System Curaflam Manschette ECO Pro" and "System FS-M R2"

Zulassungsinhaber  
*Holder of approval*

DOYMA GmbH & Co.  
DURCHFÜHRUNGSSYSTEME  
Industriestraße 43-57  
28876 Oyten  
DEUTSCHLAND

Zulassungsgegenstand  
und Verwendungszweck  
*Generic type and use  
of construction product*

Rohrabschottung  
*pipe penetration seal*

Geltungsdauer:  
*Validity:* vom  
*from*  
bis  
*to*

28 June 2013  
28 June 2018

Herstellwerk  
*Manufacturing plant*

DOYMA GmbH & Co.  
DURCHFÜHRUNGSSYSTEME  
Industriestraße 43-57  
28876 Oyten  
DEUTSCHLAND

Diese Zulassung umfasst  
*This Approval contains*

36 Seiten einschließlich 27 Anhänge  
*36 pages including 27 annexes*

## I LEGAL BASES AND GENERAL CONDITIONS

- 1 This European technical approval is issued by Deutsches Institut für Bautechnik in accordance with:
  - Council Directive 89/106/EEC of 21 December 1988 on the approximation of laws, regulations and administrative provisions of Member States relating to construction products<sup>1</sup>, modified by Council Directive 93/68/EEC<sup>2</sup> and Regulation (EC) N° 1882/2003 of the European Parliament and of the Council<sup>3</sup>;
  - Gesetz über das In-Verkehr-Bringen von und den freien Warenverkehr mit Bauprodukten zur Umsetzung der Richtlinie 89/106/EWG des Rates vom 21. Dezember 1988 zur Angleichung der Rechts- und Verwaltungsvorschriften der Mitgliedstaaten über Bauprodukte und anderer Rechtsakte der Europäischen Gemeinschaften (Bauproduktengesetz - BauPG) vom 28. April 1998<sup>4</sup>, as amended by Article 2 of the law of 8 November 2011<sup>5</sup>;
  - Common Procedural Rules for Requesting, Preparing and the Granting of European technical approvals set out in the Annex to Commission Decision 94/23/EC<sup>6</sup>;
  - Guideline for European technical approval of "Fire Stopping and Fire Sealing Products - Part 2: Penetration Seals", ETAG 026-02.
- 2 Deutsches Institut für Bautechnik is authorized to check whether the provisions of this European technical approval are met. Checking may take place in the manufacturing plant. Nevertheless, the responsibility for the conformity of the products to the European technical approval and for their fitness for the intended use remains with the holder of the European technical approval.
- 3 This European technical approval is not to be transferred to manufacturers or agents of manufacturers other than those indicated on page 1, or manufacturing plants other than those indicated on page 1 of this European technical approval.
- 4 This European technical approval may be withdrawn by Deutsches Institut für Bautechnik, in particular pursuant to information by the Commission according to Article 5(1) of Council Directive 89/106/EEC.
- 5 Reproduction of this European technical approval including transmission by electronic means shall be in full. However, partial reproduction can be made with the written consent of Deutsches Institut für Bautechnik. In this case partial reproduction has to be designated as such. Texts and drawings of advertising brochures shall not contradict or misuse the European technical approval.
- 6 The European technical approval is issued by the approval body in its official language. This version corresponds fully to the version circulated within EOTA. Translations into other languages have to be designated as such.

<sup>1</sup> Official Journal of the European Communities L 40, 11 February 1989, p. 12  
<sup>2</sup> Official Journal of the European Communities L 220, 30 August 1993, p. 1  
<sup>3</sup> Official Journal of the European Union L 284, 31 October 2003, p. 25  
<sup>4</sup> *Bundesgesetzblatt Teil I* 1998, p. 812  
<sup>5</sup> *Bundesgesetzblatt Teil I* 2011, p. 2178  
<sup>6</sup> Official Journal of the European Communities L 17, 20 January 1994, p. 34

## II SPECIFIC CONDITIONS OF THE EUROPEAN TECHNICAL APPROVAL

### 1 Definition of product/ products and intended use

#### 1.1 Definition of the construction product

##### 1.1.1 Description of the pipe penetration seal

The pipe penetration seal called "Curaflam System ECO<sup>Pro</sup>" / "System FS-M R2" mainly consists of pipe collars and a gap filling material (see Appendix 1). The pipe penetration seal shall be constructed in accordance with Appendix 3 using the components listed in Annex 1.

##### 1.1.2 Description of the components of the pipe penetration seal

###### 1.1.2.1 Pipe collar

The pipe collar, called "Curaflam ECO<sup>Pro</sup>" / "FS-M R2", of DOYMA GmbH & Co, 28876 Oyten, Germany consists of a housing and an inlay.

The housing shall consist of steel sheet and shall be sufficiently protected against corrosion.

The inlay shall consist of the intumescent material "Intusit pro" of DOYMA GmbH & Co, 28876 Oyten, Germany and shall be loosely inserted into the sheet steel housing.

The dimensions of the pipe collars, the housings and the inlays shall comply with the information given in Appendix 1.

###### 1.1.2.2 Gap filling material

For closing joints a non-combustible material (class A1 or A2-s1,d0 according to EN 13501-1) shall be used which is dimensionally stable, as e. g. concrete, cementitious or gypsum mortar.

#### 1.2 Intended use

##### 1.2.1 General

1.2.1.1 The pipe penetration seal is used to seal off openings in accordance with section 1.2.3 in fire-resistant walls and floors in accordance with section 1.2.2 penetrated by pipes in accordance with section 1.2.3<sup>7</sup> and serves to preserve the fire resistance of the wall or floor in the vicinity of the penetrations.

1.2.1.2 Depending on the pipe material, the pipe dimensions and the installation conditions the pipe penetration seal reaches a maximum fire resistance class of EI 90-U/U or EI 90-U/C (see also section 2.2).

1.2.1.3 The pipe penetration seal can be used in interiors with and without moisture loads (see section 2.5); for the intumescent component use category Y<sub>2</sub> in accordance with EOTA TR 024 was verified.

##### 1.2.2 Building elements (walls and floors)

The pipe penetration seal may be used in flexible walls ( $d_W \geq 94$  mm), rigid walls ( $d_W \geq 100$  mm) and rigid floors ( $d_D \geq 150$  mm) according to Appendix 2. The walls and floors shall be classified according to EN 13501-2 (max. EI 90) in accordance with the fire resistance period required.

<sup>7</sup> The technical provisions of the Member States for the design of piping systems and the reliability of pipe penetrations are not affected by this.

### 1.2.3 Openings (in the building elements)

- 1.2.3.1 The pipe collars may be used to close openings, if the size of the opening allows the collar to be fixed to the building element.
- 1.2.3.2 The pipe collars may be used to close openings, if the distance between the opening to be sealed off and other openings or components is at least 200 mm. For the distance between adjacent openings for pipe penetration seals according to this ETA see section 1.2.4.4.

### 1.2.4 Services (Installations)

- 1.2.4.1 The pipe penetration seal may be used on straight pipes which are fixed perpendicular to the wall or floor surface (see Annexes 7 to 23). The pipes shall consist of the pipe materials listed in Annexes 7 to 23 (depending on the fire resistance class required) and shall have dimensions<sup>8</sup> according to Annexes 7 to 23 (depending on the installation conditions and the fire resistance class required).

Where applicable, the pipes may be insulated with an expanded closed cell polyethylene strip of up to 5 mm thickness with a reaction to fire class E<sub>L</sub> according to EN 13501-1 (see Annexes 7 to 23).

Where applicable, the pipes may have sockets in the area of the penetration

- 1.2.4.2 For wall applications, the first support of the pipes shall be at a distance of ≤ 500 mm on both sides of the wall. The supports shall be non-combustible in their essential parts.
- 1.2.4.3 The pipe work shall only be used for non-combustible liquids and fluids, pneumatic dispatch systems or vacuum cleaning pipes.

The regulations of the Member States shall be observed for more precise specifications of the pipe works (intended use of pipes) for which the penetration seal may be used (e. g. drinking water pipes, heating pipes, waste water pipes)<sup>9</sup>.

- 1.2.4.4 The pipes, for which the collars according to this ETA may be used, shall have a distance of at least 100 mm between each other.

Deviating from this, the following applies to fire resistance class EI 90-U/C: surface-mounted collars on single straight pipes fixed perpendicular to the surface of the building element may be installed contacting each other, provided there are no areas (triangular interstices) between the pipes which can not be filled completely according to Appendix 3 (linear arrangement).

### 1.2.5 Working life

The provisions in this European technical approval are based on an assumed working life of 10 years for the pipe penetration seal "Curafam System ECO<sup>Pro</sup>" / "System FS-M R2" provided the conditions laid down in sections 4 and 5 relating to manufacturing, installation, use and repair are met. The information provided on the working life cannot be interpreted as a guarantee given by the manufacturer, but should be regarded only as a means for choosing the right products in relation to the expected economically reasonable working life of the construction.

<sup>8</sup> Outer pipe diameter (d<sub>A</sub>) and pipe wall thickness (s)

<sup>9</sup> The pipe penetration seal may only be fitted to these pipe work types if it fulfils the classification required in the respective country. Particular attention must be paid to the ending of the classification, which reflects the pipe end situation from the fire resistance tests performed to verify the fitness for use (see section 2.3).

## 2 Product characteristics and methods of verification

### 2.1 General

2.1.1 The fitness of the pipe penetration seal for the intended use was evaluated in accordance with ETAG 026 Part 2:2008-01-01.

For the evaluation of the pipe penetration seal, the product properties "reaction to fire", "fire resistance", "emission of dangerous substances" as well as "durability and serviceability" were taken into consideration.

2.1.2 The product properties specified in sections 2.2 to 2.5 only apply to the penetration seal and its components described in this ETA. Deutsches Institut für Bautechnik shall be immediately notified of any changes to the materials, composition, dimensions or properties of these components. Deutsches Institut für Bautechnik will then decide if a new evaluation is required.

### 2.2 Reaction to fire

The metal casing and the inlay of the pipe collar fulfil the requirements for the reaction to fire classes according to EN 13501-1 given in Appendix 1.

### 2.3 Fire resistance

The pipe penetration seal was tested in accordance with prEN 1366-3:07/2007 and EN 1366-3:2009-07. As a maximum, the penetration seal fulfils the requirements of Class EI 90-U/U or EI 90-U/C according to EN 13501-2 depending on the pipe dimensions, the pipe material, the installation conditions and the type of the building element (see Appendix 2).

In the annexes the maximum fire resistance class verified – under the respective installation conditions and for the respective pipe dimensions – is specified. If installed in walls or floors of the same thickness and density and with the same structure as specified there, but with a lower fire resistance class, the fire resistance class of the pipe penetration seal is reduced to the fire resistance class of the wall or floor.

The fire resistance classes specified in the annexes with the ending -U/U cover the classes of the same fire resistance duration, but with the endings -U/C, -C/U and -C/C. The fire resistance classes with the ending -U/C cover the classes of the same fire resistance duration, but with the ending -C/C.

### 2.4 Emission of dangerous substances

The inlay made from the intumescent material "Intusit pro" does not contain substances registered as dangerous substances in the list of the European Commission.

For assessment purposes, the chemical compositions of the material were made available to the Deutsches Institut für Bautechnik.

Note: In addition to the specific clauses relating to dangerous substances contained in this European technical approval, there may be other requirements applicable to the products falling within its scope (e. g. transposed European legislation and national laws, regulations and administrative provisions). In order to meet the provisions of the Construction Products Directive, these requirements need also to be complied with, when and where they apply.

### 2.5 Durability and serviceability

The inlay made from the intumescent material "Intusit pro" fulfils the requirements of use category Y<sub>2</sub> in accordance with EOTA TR 024. That means that the materials can be exposed to the conditions in interiors with and without moisture loads, without expecting significant changes in fire protection characteristics.

Furthermore no significant changes in expansion ratio and expansion pressure of the material were observed after exposure to a constant temperature of 80 °C, exposure to permanent wetness (water immersion) and the contact to plastics (PVC, PE) – in each case tested according to EOTA TR 024.

### 3 Evaluation and attestation of conformity and CE marking

#### 3.1 System of attestation of conformity for the pipe collar

According to Decision 1999/454/EG, amended by Decision 2001/596/EC of the European Commission<sup>10</sup>, system 1 of the attestation of conformity applies.

This system of attestation of conformity is defined as follows:

System 1: Certification of the conformity of the product by an approved certification body on the basis of:

- (a) Tasks of the manufacturer:
  - (1) factory production control;
  - (2) further testing of samples taken at the factory by the manufacturer in accordance with a prescribed test plan;
- (b) Tasks of the approved body:
  - (3) initial type-testing of the product;
  - (4) initial inspection of the factory and of factory production control;
  - (5) continuous surveillance, assessment and approval of factory production control.

Note: Approved bodies are also referred to as "notified bodies".

#### 3.2 Responsibilities

##### 3.2.1 Tasks of the manufacturer

###### 3.2.1.1 Factory production control

The manufacturer shall exercise permanent internal control of production. All the elements, requirements and provisions adopted by the manufacturer shall be documented in a systematic manner in the form of written policies and procedures, including records of results performed. The factory production control shall ensure that the product is in conformity with this European technical approval.

The manufacturer may only use the initial/raw/constituent materials stated in the technical documentation of this European technical approval.

The factory production control shall be in accordance with the control plan dated 28. June 2013 relating to the European technical approval ETA-13/0910 granted on 28. June 2013, which is part of the technical documentation of this European technical approval. The control plan is laid down in the context of the factory production control system operated by the manufacturer and deposited with Deutsches Institut für Bautechnik.<sup>11</sup>

The results of factory production control shall be recorded and evaluated in accordance with the provisions of the control plan.

<sup>10</sup> Official Journal of the European Communities 178/52, 14 July 1999

<sup>11</sup> The control plan is a confidential part of the European technical approval and only handed over to the approved body involved in the procedure of attestation of conformity. See section 3.2.2.

### 3.2.1.2 Other tasks of the manufacturer

The manufacturer shall provide a technical datasheet and an installation guide containing at least the following information:

#### Technical data sheet:

##### 1. Field of application:

- Building elements into which the penetration seal may be installed, type and properties of the building elements, such as minimum thickness, density and – in the case of lightweight constructions – the construction requirements.
- Installations that may pass through the penetration seal, type and properties of the installations (including insulation if relevant), such as materials, diameter, thickness; necessary/permitted supports/fastenings; distances.
- Dimensions, minimum thicknesses etc. of the penetration seal
- Climatic conditions covered by the ETA

##### 2. Construction of the penetration seal including the necessary components and additional products (i.e. gap filling material) with clear indications whether they are generic or specific.

#### Installation instructions:

- Installation method (e. g. preparation of the supporting structure before installing the penetration seal)
- The sequence of working steps to be followed

The manufacturer shall, on the basis of a contract, involve a body which is approved for the tasks referred to in section 3.1 for products in accordance with ETAG 026-2, in order to undertake the actions laid down in section 3.2.2. For this purpose, the control plan referred to in sections 3.2.1.1 and 3.2.2 shall be handed over by the manufacturer to the approved body involved.

The manufacturer shall make a declaration of conformity, stating that the construction product is in conformity with the provisions of the European technical approval ETA-13/0910 issued on 28. June 2013.

### 3.2.2 Tasks for the approved bodies

The approved bodies shall perform the following tasks in accordance with the provisions laid down in the control plan:

- Initial type-testing of the product
- Initial inspection of factory and factory production control
- Continuous surveillance, assessment and approval of factory production control

The approved bodies shall record the essential points of their actions referred to above and state the results obtained and conclusions made in a written report.

The approved certification body involved by the manufacturer shall issue an EC certificate of conformity of the product stating the conformity with the provisions of this European technical approval.

In cases where the provisions of the European technical approval and its control plan are no longer fulfilled, the certification body shall withdraw the certificate of conformity and inform Deutsches Institut für Bautechnik without delay.

### 3.3 CE marking

The CE marking shall be affixed on the pipe collar as well as on the packaging or the accompanying commercial documents. The letters "CE" shall be followed by the identification number of the approved certification body and be accompanied by the following additional information:

- the name and address of the manufacturer (legal entity responsible for the manufacture),
- the last two digits of the year in which the CE marking was affixed,
- the number of the EC certificate of conformity for the product,
- the number of the European technical approval,
- the number of the guideline for European technical approval,
- the use category,
- the designation of the product (trade name) (with indication of the size),
- declaration of any dangerous substances or "no dangerous substances",
- "see ETA-13/0910 for other relevant characteristics".

For an example of the CE marking see Appendix 4.

## 4 Assumptions under which the fitness of the product for the intended use was favourably assessed

### 4.1 General

#### 4.1.1 It is assumed that

- the penetration seal complies with the specifications in this ETA and the installation was carried out in accordance with this ETA and also in accordance with the technical data sheet and the installation instructions by the manufacturer,
- damages to the penetration seal are repaired accordingly,
- the seal is installed only in the building elements specified in this ETA,
- only installations in accordance with the specifications in this ETA pass through the openings (Parts or service support constructions other than those in accordance with section 1.2 shall not pass through the penetration seal.),
- pneumatic dispatch systems, compressed air systems, etc. are switched off by additional means in case of fire,
- the installation of the penetration seal does not affect the stability of the adjacent building elements – even in case of fire,
- the installations are fixed to the adjacent building elements (not to the seal) in accordance with the relevant regulations in such a way that, in case of fire, no additional mechanical load is imposed on the seal,
- the support of the installations is maintained for the classification period required.

4.1.2 This European technical approval does not address any risks associated with the emission of dangerous liquids or gases caused by failure of the pipe(s) in case of fire nor does it prove the prevention of the transmission of fire through heat transfer via the medium in the pipes.

4.1.3 This European technical approval does not verify the prevention of destruction of adjacent building elements with fire separating function or of the pipes themselves due to distortion forces caused by extreme temperatures. These risks shall be accounted for by taking appropriate measures when designing or installing the pipe work.



**European technical approval****ETA-13/0910****Page 9 of 36 | 28 June 2013****English translation prepared by DIBt**

The mounting or hanging of the pipes or the layout of the pipe work shall be implemented in such a way that the pipes and the fire-resistant building elements shall remain functional for at least 90 minutes (corresponding to the target period of fire resistance).

- 4.1.4 The risk of downward spread of fire caused by burning material which drips through a pipe to floors below, is not considered in this ETA (see EN 1366-3:2009-07, section 1).
- 4.1.5 The durability assessment does not take account of the possible effect on the penetration seal of substances permeating through the pipe walls.

**4.2 Production**

The European technical approval was issued for the product on the basis of agreed data/information, deposited with Deutsches Institut für Bautechnik, which identifies the product that has been assessed and judged. Changes to the product or production process, which could result in this deposited data/information being incorrect, shall be reported to Deutsches Institut für Bautechnik before the changes are introduced. Deutsches Institut für Bautechnik will decide whether or not such changes affect the approval and consequently the validity of the CE marking on the basis of the approval, and if so whether further assessment or alterations to the approval shall be necessary.

**4.3 Installation**

The product characteristics specified in this European technical approval shall only apply if the penetration seal is installed in accordance with the specifications in Appendix 3 and also with the technical data sheet and the manufacturer's installation instructions.

**5 Indications to the manufacturer****5.1 Packaging, transport and storage**

- 5.1.1 The manufacturer's specifications for packaging, transport and storage shall be observed.
- 5.1.2 The packaging of the pipe collar shall contain the following information:
- Trade name or trademark or other symbol identifying the product
  - The date of manufacture (day, month, year or coded information)
- 5.1.3 The pipe collar shall be packaged for delivery in compliance with the usual delivery conditions and providing sufficient protection against the effects of normal handling.

**5.2 Use, maintenance, repair**

In general, no maintenance work is necessary. Repair can be performed by replacing damaged collars and/or by renewing damaged gap seals in accordance with Appendix 3.

Prof. Gunter Hoppe  
Head of Department

*beglaubigt:*  
Racinowski

Name / Manufacturer	Description
<p>"Curaflam ECO<sup>Pro</sup>" / "FS-M R2" DOYMA GmbH &amp; Co 28876 Oyten Germany</p>	<p><b>Pipe collar</b> The pipe collar consists of a sheet steel housing and an inlay made from the intumescent material "Intusit pro". The housing has a hook closure device (hook-shaped straps and cut-outs) and up to six fixing straps. dimensions: according to Annex 2</p> <p><b>Inlay</b> The inlay consists of the intumescent material "Intusit pro". dimensions: according to Annexe 2</p> <p><b>Housing</b> The housing consists of 0,6 mm, 0,8 mm or 1 mm thick steel sheet. The housing shall be sufficiently protected against corrosion. The material for the metal housing is classified according to Commission Decision 96/603/EC (as amended): Class A1 dimensions: according to Annexe 2</p>
<p>Intumescent material "Intusit pro" DOYMA GmbH &amp; Co 28876 Oyten Germany</p>	<p><b>Intumescent material</b> Reaction to fire according to EN 13501-1: class E Density: 1250 kg/m<sup>3</sup> ± 10 % Loss of mass on heating*: 67 % ± 5 % Expansion ratio*: 10 to 18 (tested on samples 3 mm thick)<sup>1</sup> Expansion pressure*: 0,6 N/mm<sup>2</sup> to 1,2 N/mm<sup>2</sup><sup>2</sup></p>
<p>gap filling material, manufacturer-independent</p>	<p>The filling shall consist of a non-combustible material (class A1 or A2-s1,d0 according to EN 13501-1) which is dimensionally stable, as e. g. concrete, cementitious or gypsum mortar.</p>
<p>* tested according to ETAG 026-2 (also see TR 024) 1) EOTA TR 024:07/2009, Annex A1, test method 1 2) EOTA TR 024:07/2009, Annex A2, method 4</p>	
<p>"System Curaflam Manschette ECO Pro" and "System FS-M R2"</p>	
<p><b>APPENDIX 1 – DESCRIPTION OF THE PRODUCT</b> Description of the components of the pipe penetration seal</p>	
<p>Annex 1</p>	

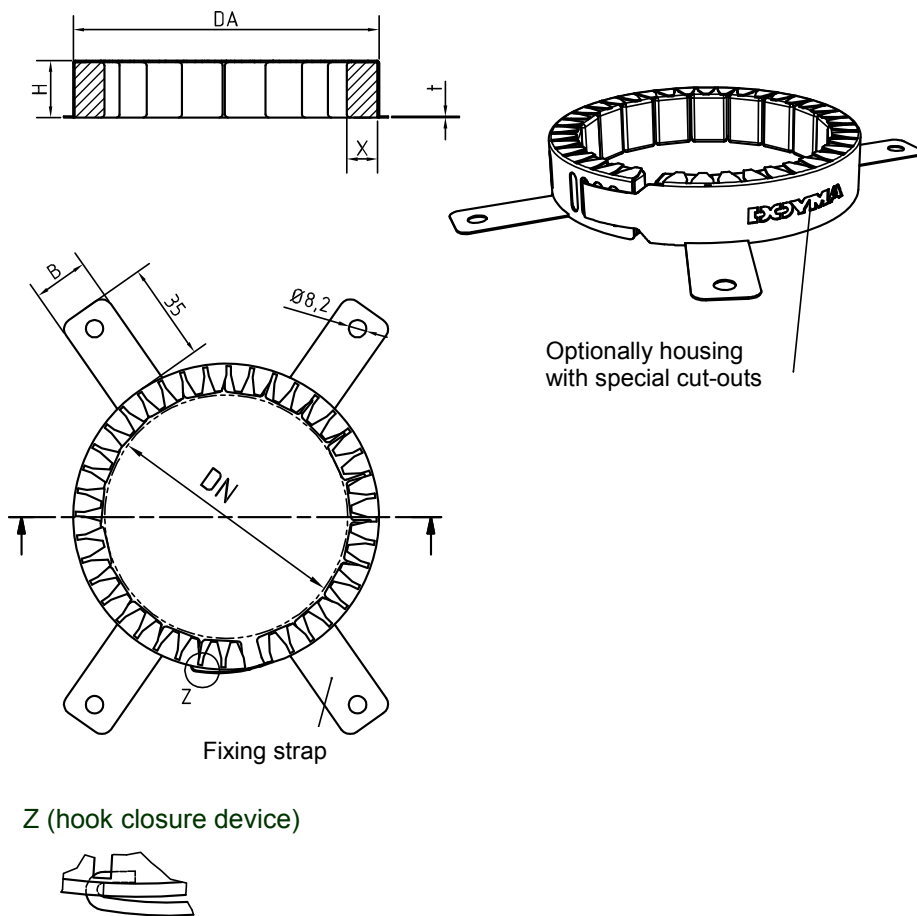

Z (hook closure device)

DN [mm]	DA [mm]	H [mm]	B [mm]	t [mm]	number of straps	X [mm]
32	43	30	15	0,6	3	6
40	56	30	15	0,6	3	7,8
50	70	30	15	0,6	3	9,6
63	85	30	15	0,6	4	10,4
75	99	30	15	0,6	4	12,0
90	117	30	25	0,6	4	12,8
110	141	30	25	0,8	4	14,5
125	154	50	20	1,0	4	13,2
140	178	50	20	1,0	4	18,0
160	200	50	20	1,0	5	18,9

"System Curaflam Manschette ECO Pro" and "System FS-M R2"

**APPENDIX 1 – DESCRIPTION OF THE PRODUCT**  
Description of the components of the pipe penetration seal

Annex 2

**Pipes perpendicular to the surface**

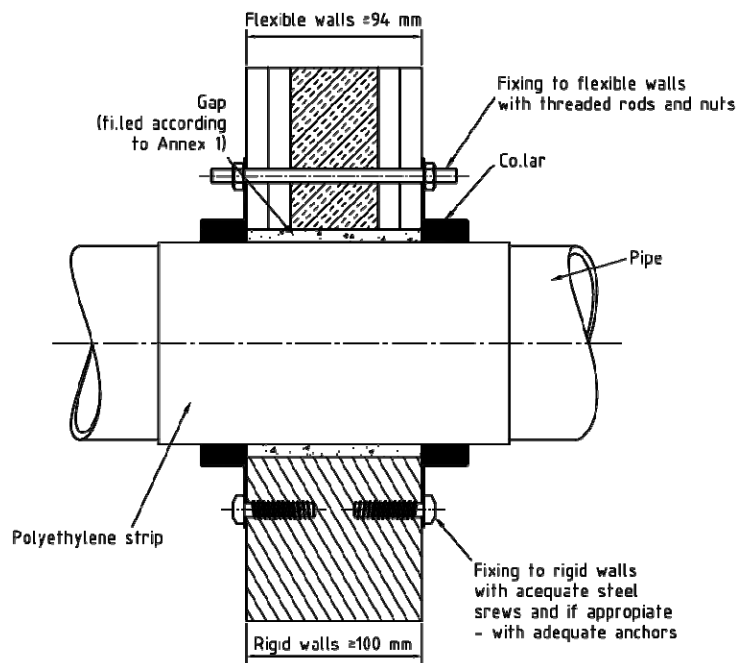

**Installation on 2 x 45°-situation**

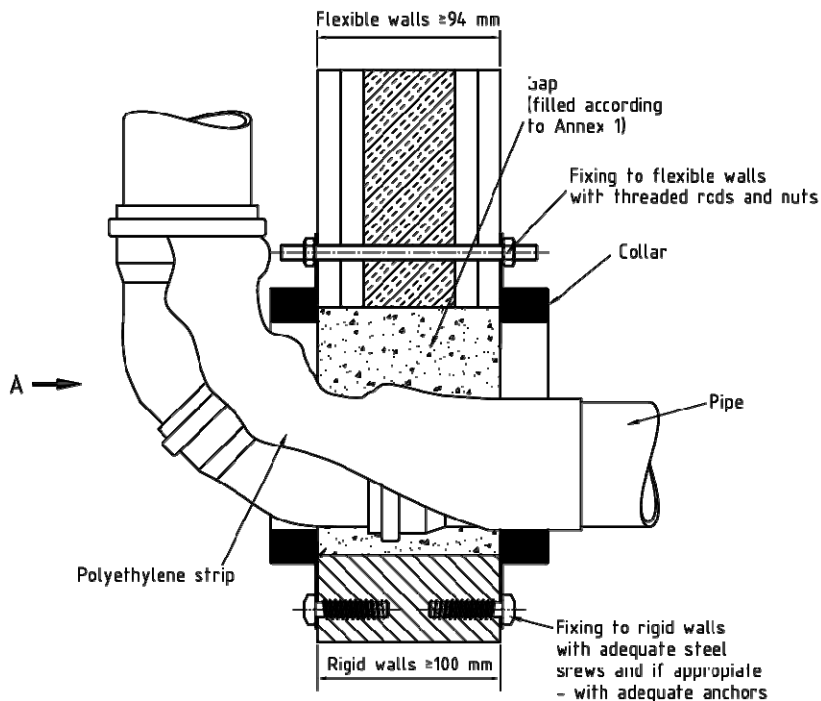

View A

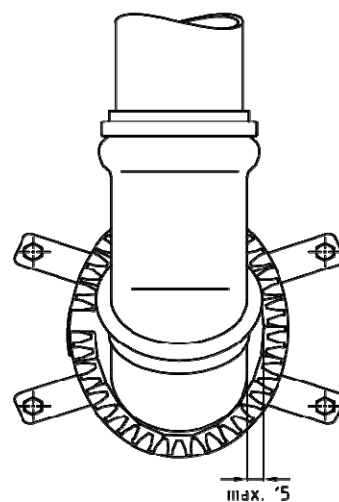

Dimensions in mm

"System Curaflam Manschette ECO Pro" and "System FS-M R2"

**APPENDIX 1 – DESCRIPTION OF THE PRODUCT**

Design of the pipe penetration seal for walls installation – perpendicular and inclined pipes

Annex 3

**Pipes perpendicular to the surface**

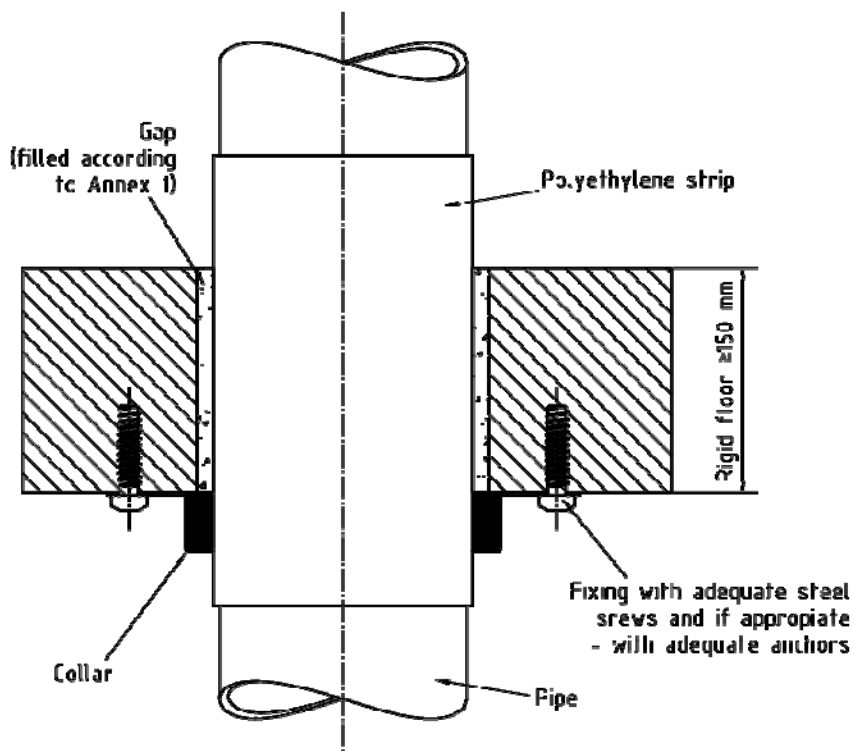

**Installation on 2 x 45°-situation**

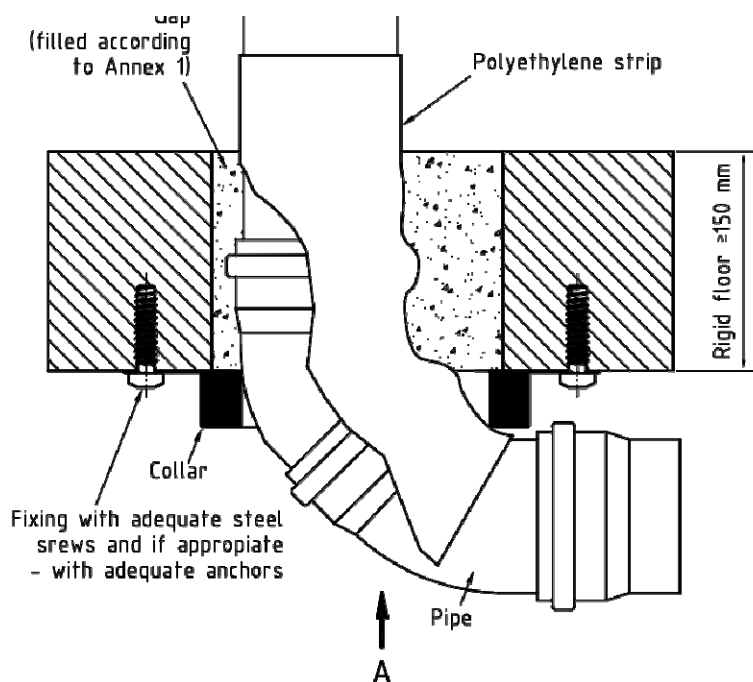

**View A**

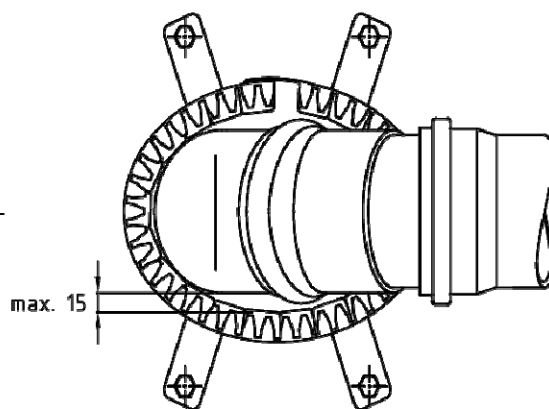

Dimensions in mm

"System Curaflam Manschette ECO Pro" and "System FS-M R2"

**APPENDIX 1 – DESCRIPTION OF THE PRODUCT**

Design of the pipe penetration seal for floor installation – perpendicular and inclined pipes

Annex 4

### Mortared pipe collars

Collar full mortared into the floor

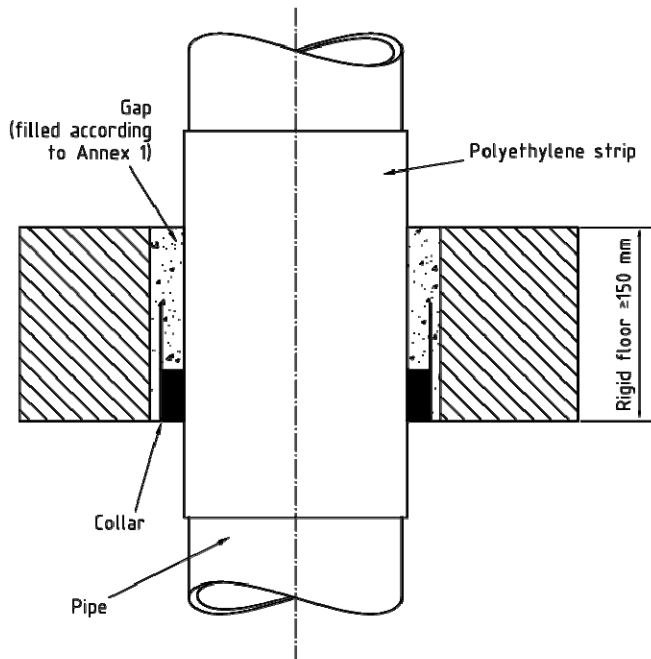

Fixing strap mortared into the floor

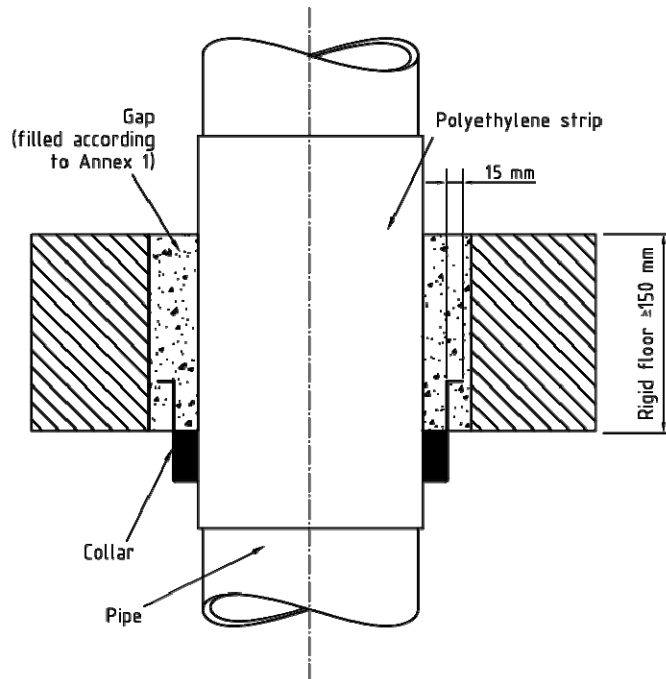

Dimensions in mm

"System Curaflam Manschette ECO Pro" and "System FS-M R2"

#### APPENDIX 1 – DESCRIPTION OF THE PRODUCT

Design of the pipe penetration seal for floor installation – inclined pipe penetration with socket in the area of the penetration/ cast pipe collars

Annex 5

The pipe penetration seal may be used in

**Rigid walls (MW)**

- of masonry, concrete, reinforced concrete or aerated concrete
- density  $\geq 630 \text{ kg/m}^3$
- thickness  $\geq 100 \text{ mm}$
- The walls shall be classified according to EN 13501-2 (maximum EI 90) corresponding to the required fire resistance period.

**Flexible walls (LTW)**

- flexible walls with a steel stud substructure and a lining on both sides made from min. 2 layers of 12,5 mm thick cementitious or gypsum based slabs with a fire reaction class A1 or A2 according to EN 13501-1
- flexible walls with a wood stud substructure and a lining on both sides made from min. 2 layers of 12,5 mm thick cementitious or gypsum based slabs with a fire reaction class A1 or A2 according to EN 13501-1

The distance between the wood substructure and the seal shall be  $\geq 100 \text{ mm}$  and the cavity between the linings of the wall, the wood substructure and the seal shall be tightly clogged with mineral wool of fire reaction class A1 or A2 according to EN 13501-1 in a depth of minimum 100 mm.

- thickness  $\geq 94 \text{ mm}$
- The walls shall be classified according to EN 13501-2 (maximum EI 120) corresponding to the required fire resistance period.

**Rigid floors (D)**

- of masonry, concrete, reinforced concrete or aerated concrete
- density  $\geq 630 \text{ kg/m}^3$
- thickness  $\geq 150 \text{ mm}$
- The floors shall be classified according to EN 13501-2 (maximum EI 90) corresponding to the required fire resistance period.

**Note:** This ETA do not cover the installation of the seal in special walls, i. e. in sandwich panel constructions.

"System Curaflam Manschette ECO Pro" and "System FS-M R2"

**APPENDIX 2 – FIELD OF APPLICATION**  
Walls and floors

Annex 6

### Pipe group A

Pipes made from PVC-U according to EN 1452-1 and also to DIN 8061/8062

Building element	Installation conditions	Fire resistance classification (FWKL)	
		EI 90-U/U	EI 90-U/C
LTW, MW	Perpendicular pipes without polyethylene strip	see figure 1	see figure 2
LTW, MW	Installation on 2 x 45°-situation respectively without and possibly with polyethylene strip up to 5 mm thick		see figure 3
D	Perpendicular pipes without and possibly with polyethylene strip up to 5 mm thick		see figure 4
D	Installation on 2 x 45°-situation each without polyethylene strip		see figure 5

**Figure 1 – EI 90-U/U (wall installation)**

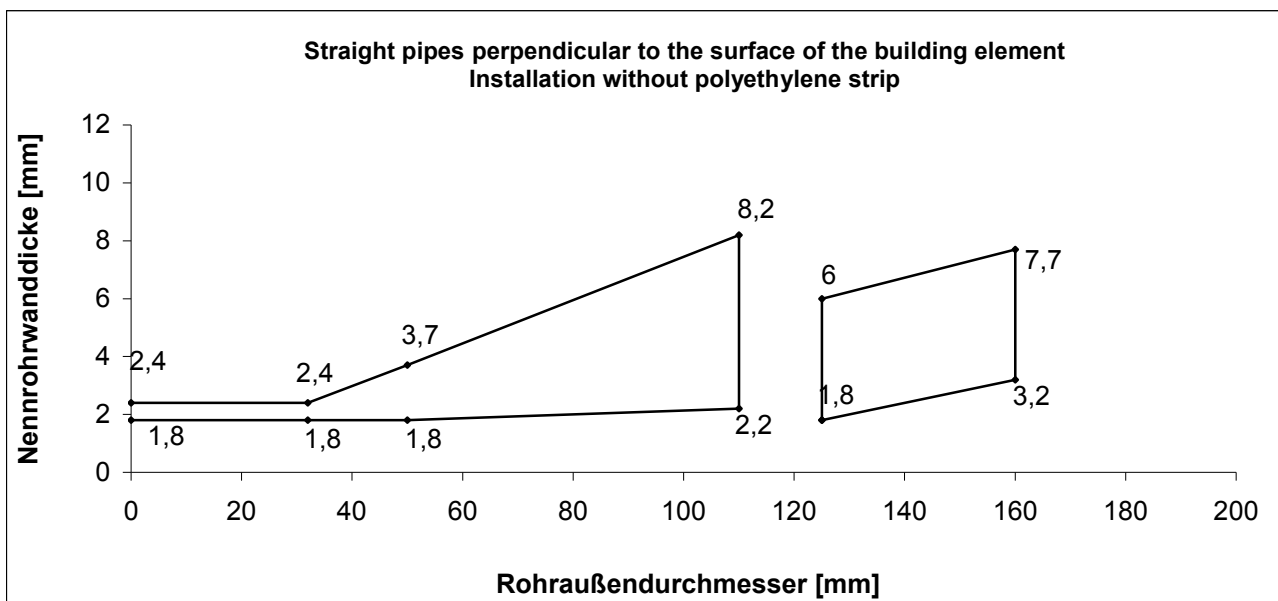

"System Curaflam Manschette ECO Pro" and "System FS-M R2"

**APPENDIX 2 – FIELD OF APPLICATION**  
Pipe dimensions for pipes of pipe group A ("PVC")

Annex 7



**Figure 2 – EI 90-U/C (wall installation)**

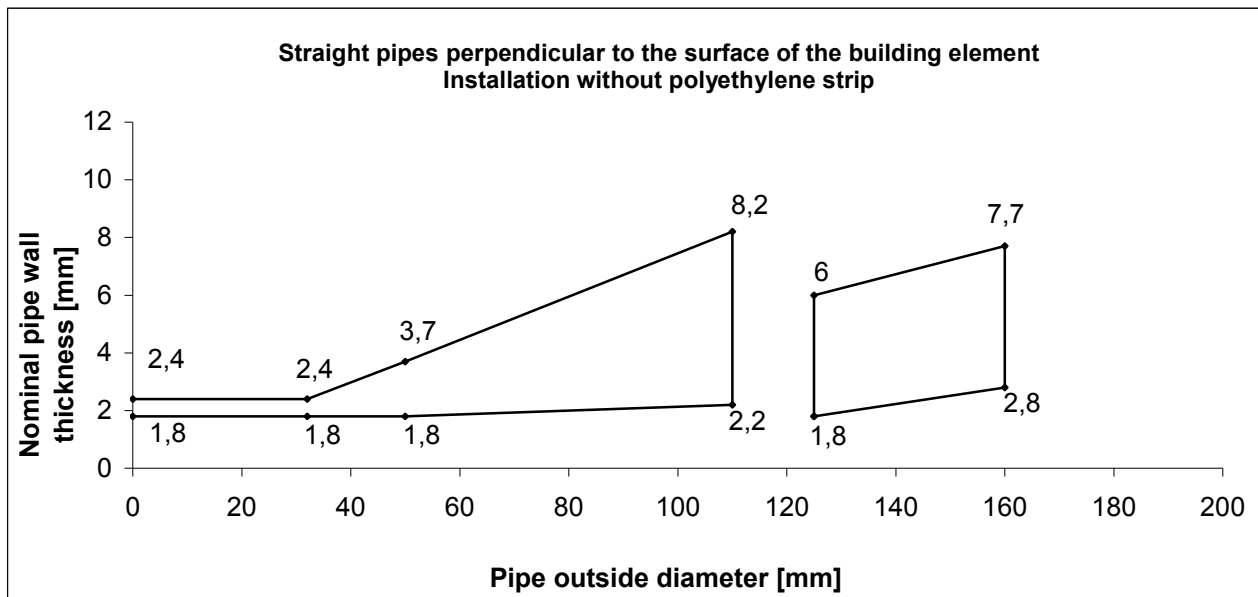

**Figure 3 – EI 90-U/C (wall installation)**

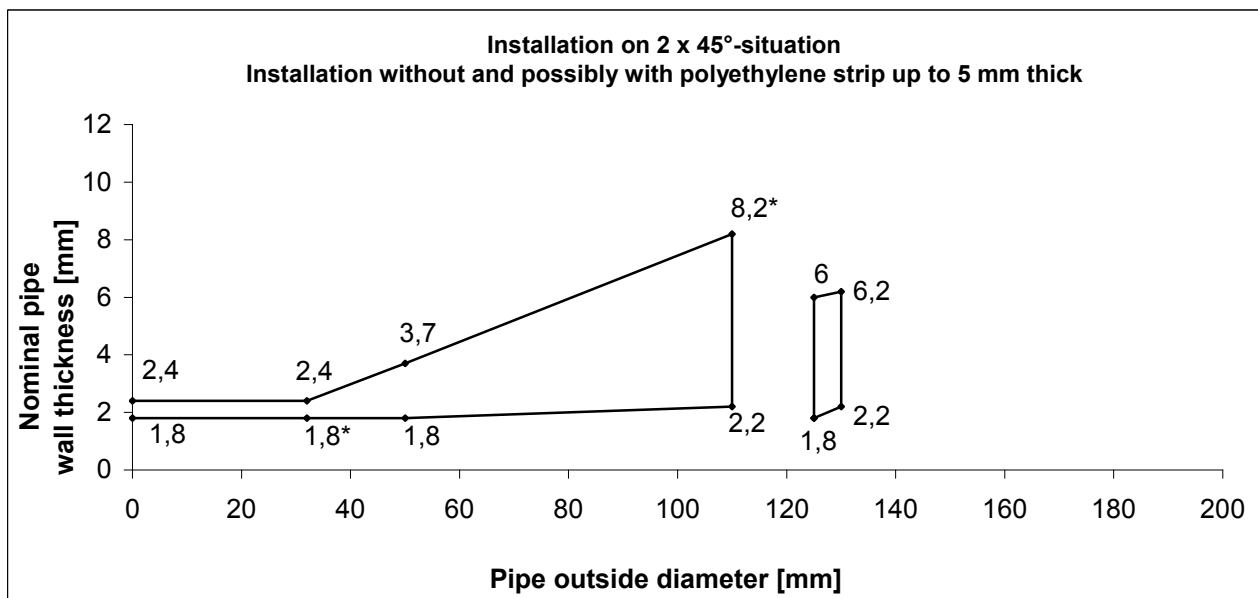

\* optionally with an up to 5 mm thick expanded closed cell polyethylene strip

"System Curaflam Manschette ECO Pro" and "System FS-M R2"

**APPENDIX 2 – FIELD OF APPLICATION**  
Pipe dimensions for pipes of pipe group A ("PVC")

Annex 8

**Figure 4 – EI 90-U/C (floor installation)**

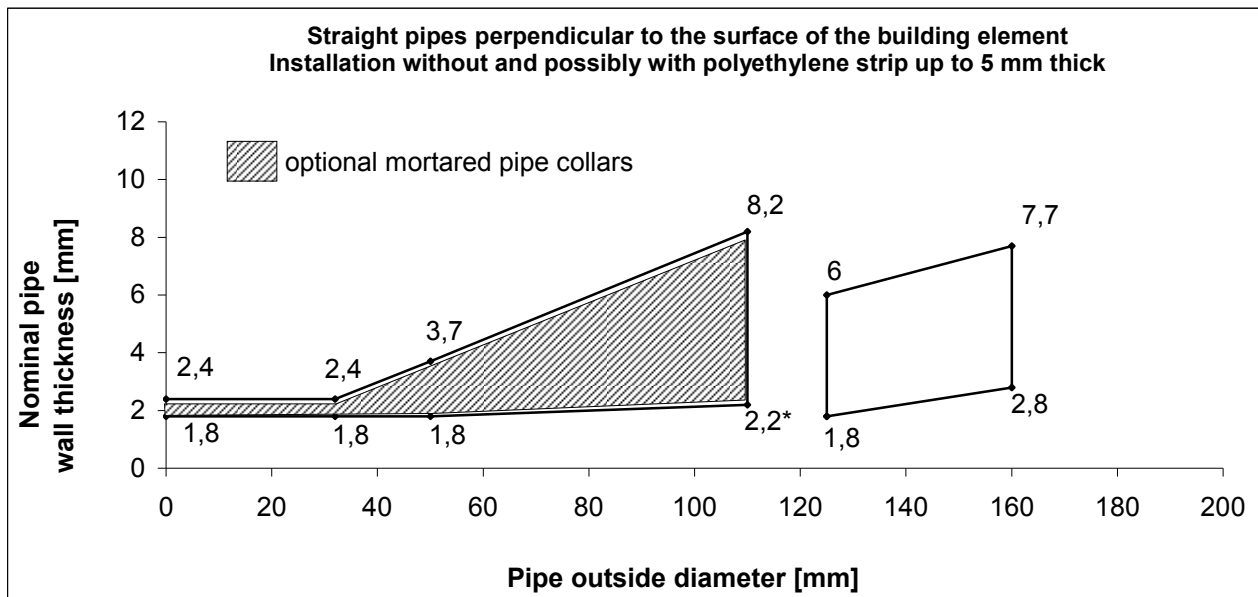

\*optionally with an up to 5 mm thick expanded closed cell polyethylene strip (only surface mounted collars)

**Figure 5 – EI 90-U/C (floor installation)**

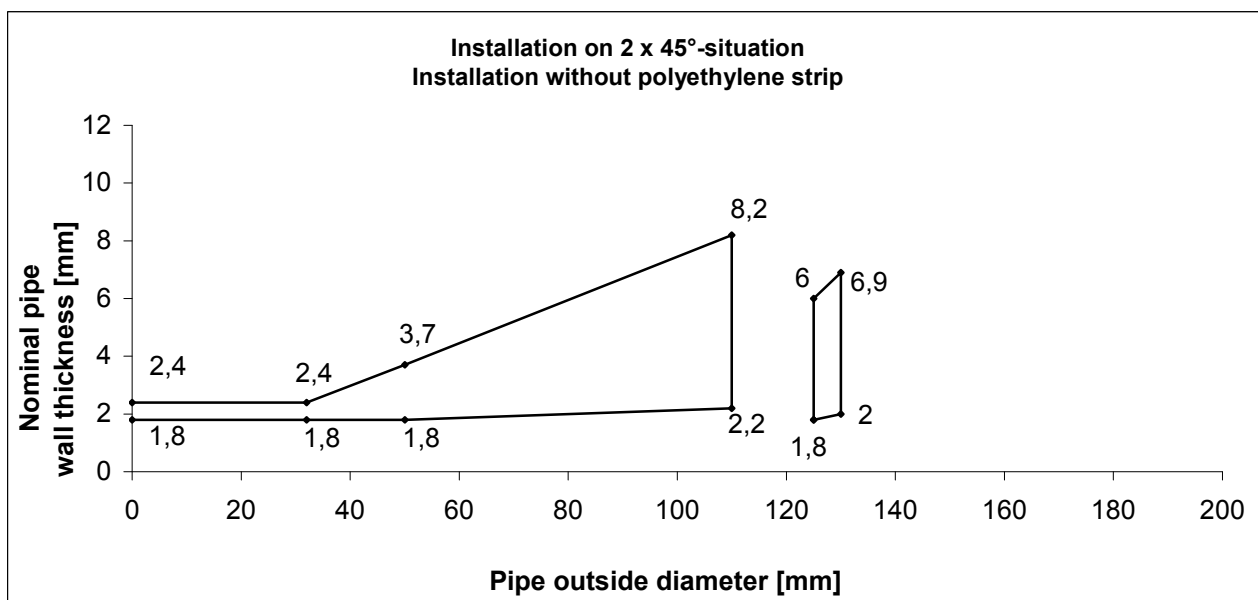

"System Curaflam Manschette ECO Pro" and "System FS-M R2"

**APPENDIX 2 – FIELD OF APPLICATION**  
Pipe dimensions for pipes of pipe group A ("PVC")

Annex 9

### Rohrgruppe B

Pipes made from PE-HD according to EN 1519-1 and also to DIN 8074/8075

Building element	Installation conditions	Fire resistance classification (FWKL)	
		EI 90-U/U	EI 90-U/C
LTW, MW	Perpendicular pipes without or for EI 90-U/C possibly with polyethylene strip up to 5 mm thick	see figure 6	see figure 7
LTW, MW	Installation on 2 x 45°-situation respectively without and possibly with polyethylene strip up to 5 mm thick		see figure 8
D	Perpendicular pipes without or for EI 90-U/C possibly with polyethylene strip up to 3 mm thick	see figure 9	see figure 10
D	Installation on 2 x 45°-situation each without polyethylene strip	see figure 11	see figure 12

**Figure 6 – EI 90-U/U (wall installation)**

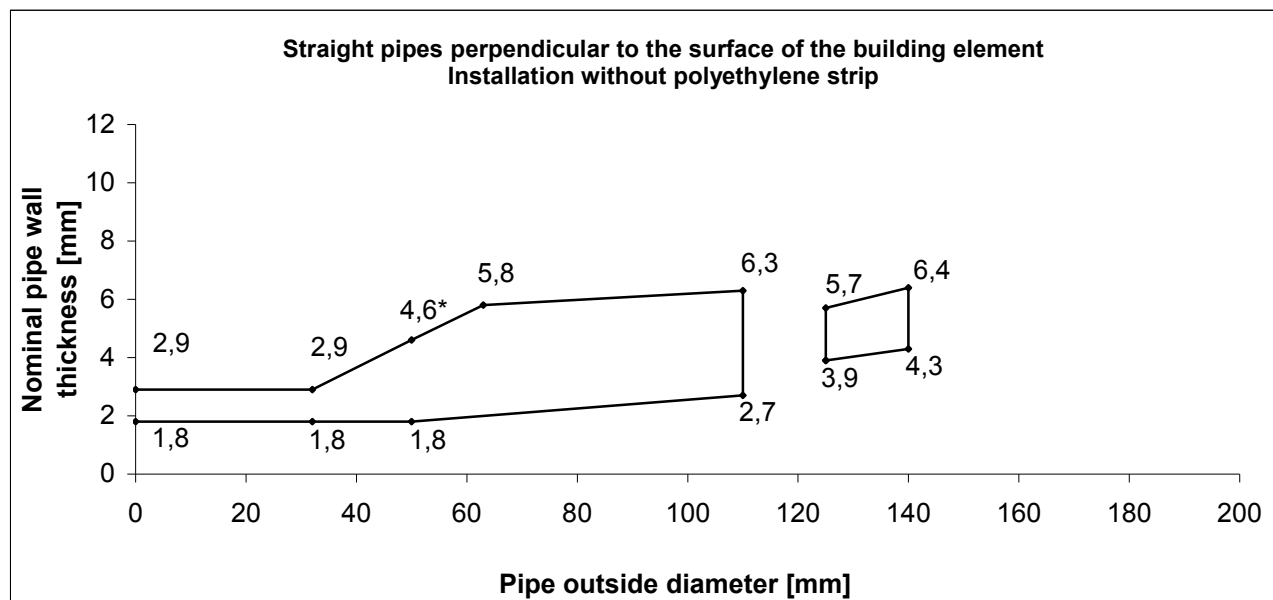

\*optionally with an up to 3 mm thick expanded closed cell polyethylene strip

"System Curaflam Manschette ECO Pro" and "System FS-M R2"

**APPENDIX 2 – FIELD OF APPLICATION**  
Pipe dimensions for pipes of pipe group B ("PE")

Annex 10

**Figure 7 – EI 90-U/C (wall installation)**

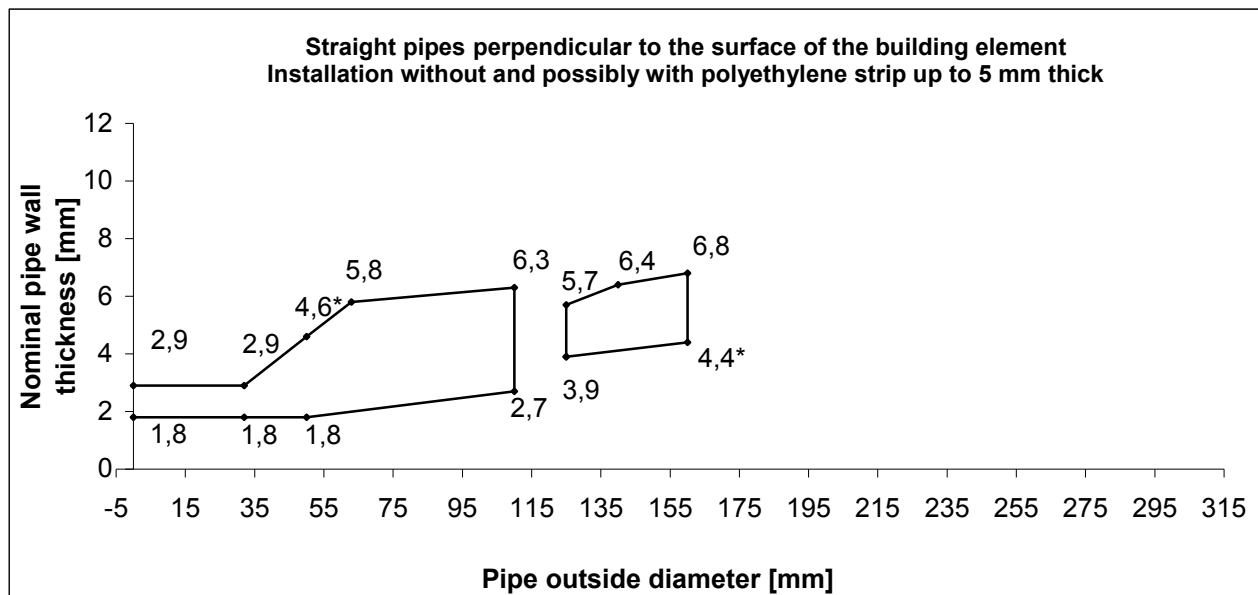

- \* optionally with an up to 5 mm thick expanded closed cell polyethylene strip
- \*\* only in rigid walls

**Figure 8 – EI 90-U/C (wall installation)**

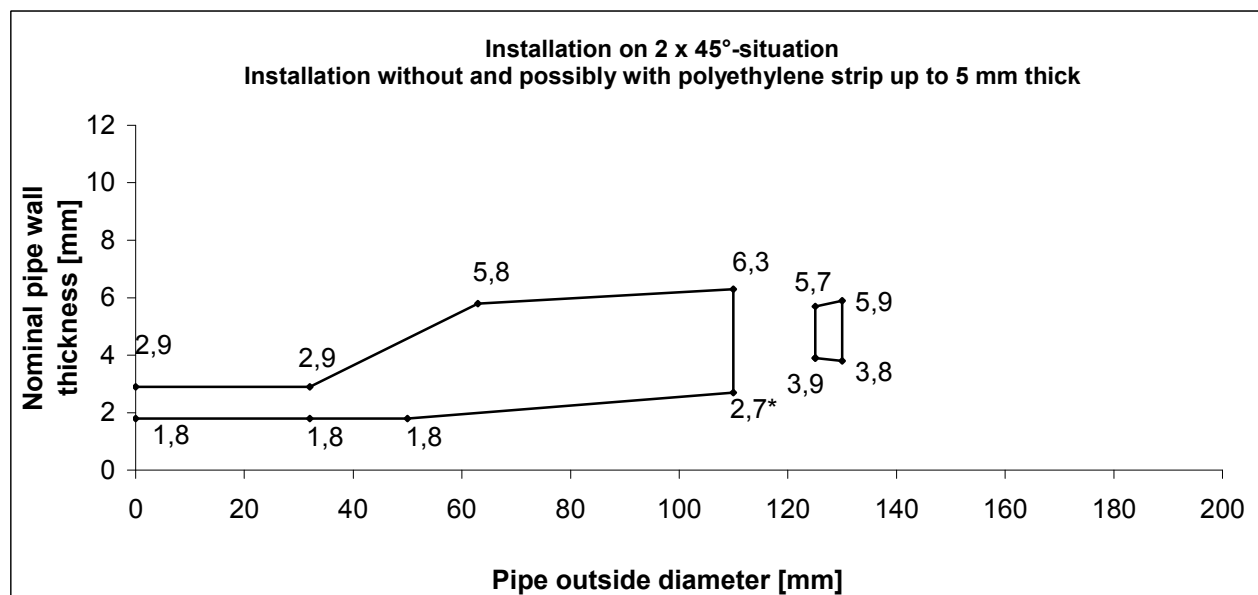

- \*optionally with an up to 5 mm thick expanded closed cell polyethylene strip

"System Curaflam Manschette ECO Pro" and "System FS-M R2"

**APPENDIX 2 – FIELD OF APPLICATION**  
Pipe dimensions for pipes of pipe group B ("PE")

Annex 11

**Figure 9 – EI 90-U/U (floor installation)**

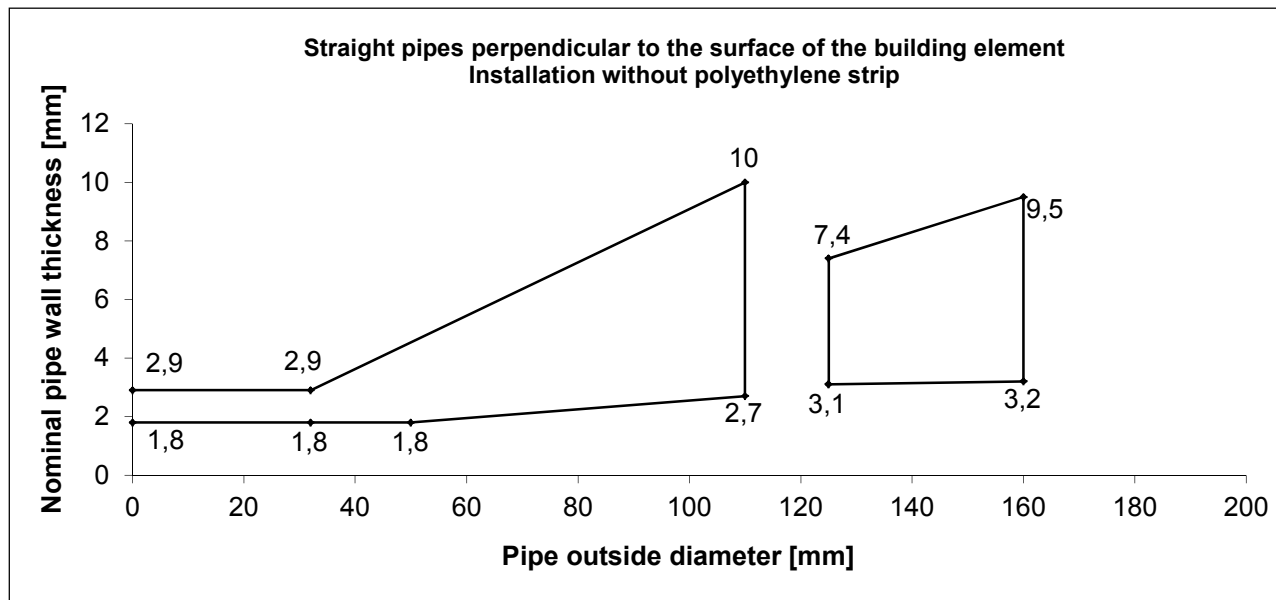

**Figure 10 – EI 90-U/C (floor installation)**

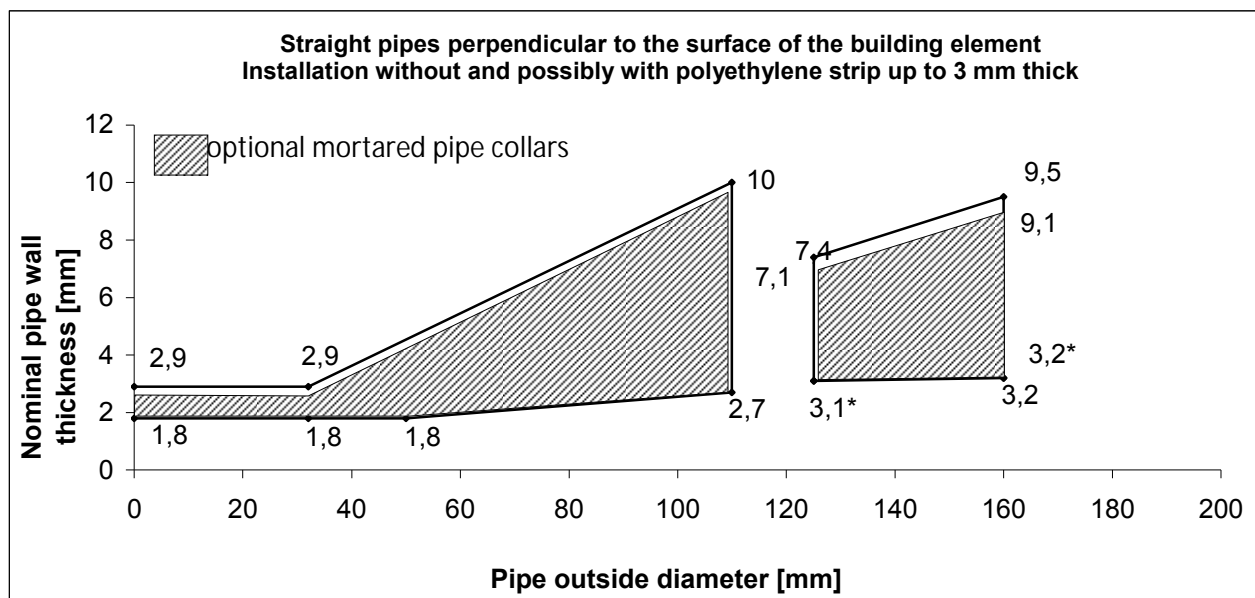

Outer pipe diameter  $\leq 110$  mm: optionally with an up to 3 mm thick expanded closed cell polyethylene strip  
\* optionally with an up to 3 mm thick expanded closed cell polyethylene strip (only surface mounted collars)

"System Curaflam Manschette ECO Pro" and "System FS-M R2"

**APPENDIX 2 – FIELD OF APPLICATION**  
Pipe dimensions for pipes of pipe group B ("PE")

Annex 12

**Figure 11 – EI 90-U/U (floor installation)**

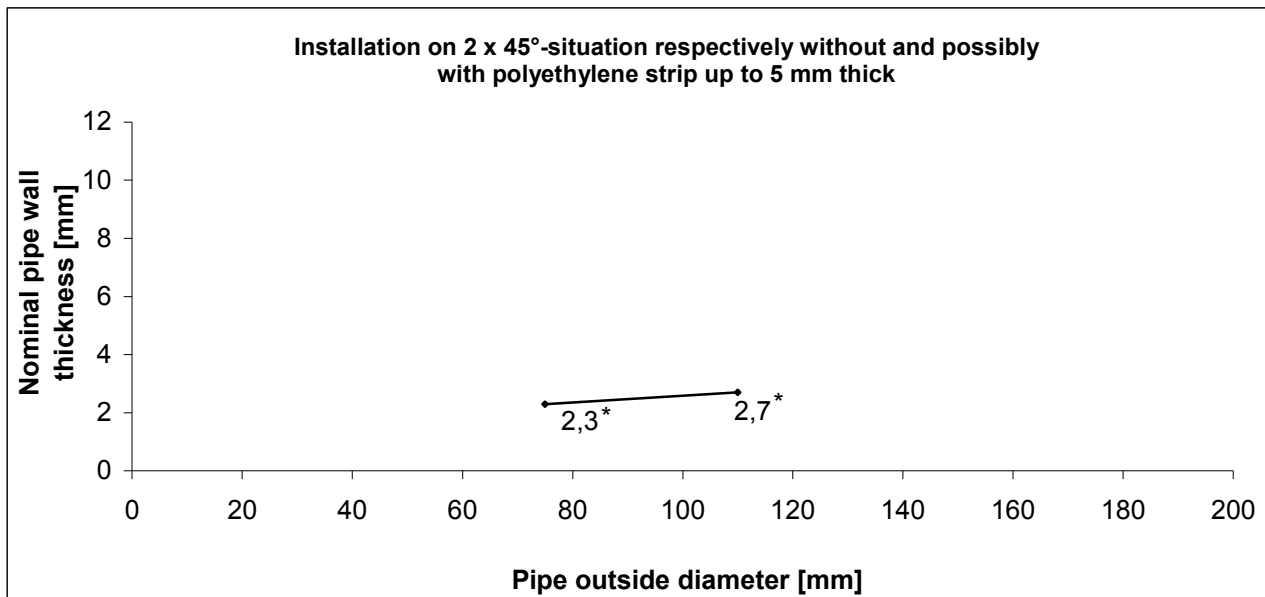

**Figure 12 – EI 90-U/C (floor installation)**

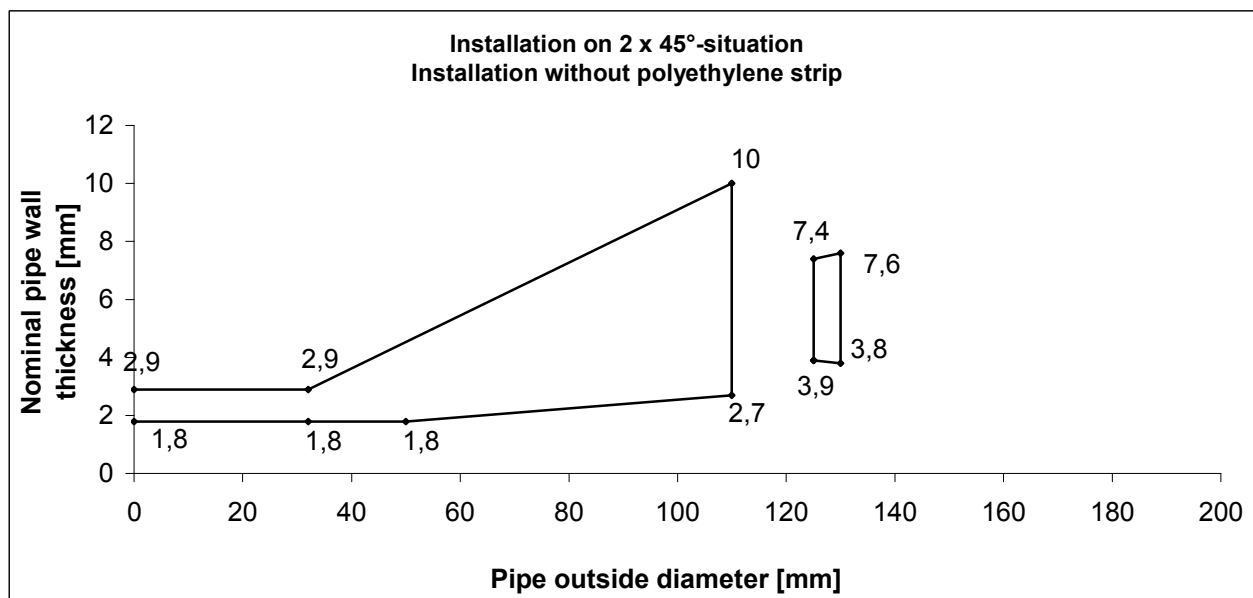

\* optionally with an up to 5 mm thick expanded closed cell polyethylene strip

"System Curaflam Manschette ECO Pro" and "System FS-M R2"

**APPENDIX 2 – FIELD OF APPLICATION**  
Pipe dimensions for pipes of pipe group B ("PE")

Annex 13

### **Pipe group C**

"Wavin AS"-pipes manufactured by Wavin GmbH, 49767 Twist, Germany (Z-42.1-228) and "Skolan dB"-pipes manufactured by Gebr. Ostendorf Kunststoffe GmbH & Co. KG, 49377 Vechta, Germany (Z-42.1-217) made from mineral reinforced polypropylene (permissible pipe dimensions for the respective installation conditions are indicated with "x" in the table below)

Wall installation							
d <sub>A</sub> [mm]	s [mm]	EI 90-U/U			EI 90-U/C		
		straight ⊥	oblique	two 45°- pipe elbows	straight ⊥	two 45°- pipe elbows	straight ⊥ mortared
58	4,0	x <sup>2</sup>			x <sup>2</sup>	x <sup>1</sup>	
78	4,5				x <sup>1</sup>	x <sup>1</sup>	
90	4,5				x <sup>1</sup>	x <sup>1</sup>	
110	5,3				x <sup>1</sup>	x <sup>1</sup>	
135	5,3				x	x	
160	5,3				x <sup>1</sup>	x	
Floor installation							
58	4,0	x <sup>2</sup>		x <sup>2</sup>	x <sup>2</sup>	x <sup>1</sup>	x <sup>1</sup>
78	4,5			x <sup>2</sup>	x <sup>1</sup>	x <sup>1</sup>	x <sup>1</sup>
90	4,5			x <sup>2</sup>	x <sup>1</sup>	x <sup>1</sup>	x <sup>1</sup>
110	5,3			x <sup>2</sup>	x <sup>1</sup>	x <sup>2</sup>	x <sup>1</sup>
135	5,3				x <sup>1</sup>	x <sup>1</sup>	x
160	5,3				x <sup>1</sup>		x

- 1 optionally with an up to 3 mm thick expanded closed cell polyethylene strip
- 2 optionally with an up to 5 mm thick expanded closed cell polyethylene strip

"System Curaflam Manschette ECO Pro" and "System FS-M R2"

#### **APPENDIX 2 – FIELD OF APPLICATION**

Pipe dimensions for pipes of pipe group C ("Skolan dB", "Wavin AS")

Annex 14

### Pipe group D

"Raupiano Plus"-pipes manufactured by REHAU AG + Co., 91058 Erlangen-Eltersdorf, Germany (Z-42.1-223) made from mineral reinforced polypropylene (permissible pipe dimensions for the respective installation conditions are indicated with "x" in the table below)

Wall installation							
d <sub>A</sub> [mm]	s [mm]	EI 90-U/U			EI 90-U/C		
		straight ⊥	oblique	two 45°- pipe elbows	straight ⊥	two 45°- pipe elbows	straight ⊥ mortared
40	1,8	x <sup>2</sup>			x <sup>2</sup>	x <sup>1</sup>	
50	1,8	x <sup>2</sup>			x <sup>2</sup>	x <sup>1</sup>	
75	1,9	x <sup>2</sup>			x <sup>2</sup>	x <sup>1</sup>	
90	2,2	x <sup>2</sup>			x <sup>2</sup>	x <sup>1</sup>	
110	2,7	x <sup>2</sup>			x <sup>2</sup>	x <sup>1</sup>	
125	3,1	x <sup>2</sup>			x <sup>1</sup>	x <sup>1</sup>	
160	3,9	x <sup>2</sup>			x <sup>1</sup>		
Floor installation							
40	1,8	x <sup>2</sup>			x <sup>2</sup>	x <sup>1</sup>	
50	1,8	x <sup>1</sup>			x <sup>1</sup>	x <sup>1</sup>	
75	1,9	x <sup>1</sup>			x <sup>1</sup>	x <sup>1</sup>	
90	2,2	x <sup>1</sup>			x <sup>1</sup>	x <sup>1</sup>	
110	2,7	x <sup>1</sup>			x <sup>1</sup>	x <sup>1</sup>	
125	3,1				x <sup>1</sup>	x <sup>1</sup>	
160	3,9	x <sup>2</sup>			x <sup>2</sup>		

- 1 optionally with an up to 3 mm thick expanded closed cell polyethylene strip
- 2 optionally with an up to 5 mm thick expanded closed cell polyethylene strip

"System Curaflam Manschette ECO Pro" and "System FS-M R2"

#### APPENDIX 2 – FIELD OF APPLICATION

Pipe dimensions for pipes of pipe group D ("Raupiano Plus")

Annex 15



### Pipe group E

"Silent-PP"-pipes manufactured by Geberit Vertriebs GmbH, 88630 Pfullendorf, Germany (Z-42.1-432) made from mineral reinforced polypropylene (permissible pipe dimensions for the respective installation conditions are indicated with "x" in the table below)

Wall installation							
d <sub>A</sub> [mm]	s [mm]	EI 90-U/U			EI 90-U/C		
		straight ⊥	oblique	two 45°- pipe elbows	straight ⊥	two 45°-pipe elbows	straight ⊥ mortared
40	2	x <sup>2</sup>			x <sup>2</sup>		
50	2	x <sup>1</sup>			x <sup>2</sup>		
75	2,6	x <sup>1</sup>			x <sup>2</sup>		
90	3,1	x <sup>1</sup>			x <sup>2</sup>		
110	3,6	x <sup>1</sup>			x <sup>2</sup>	x <sup>1</sup>	
125	4,2	x <sup>2</sup>			x <sup>2</sup>		
160	5,2	x <sup>2</sup>			x <sup>2</sup>		
Floor installation							
40	2	x <sup>2</sup>		x <sup>2</sup>	x <sup>2</sup>	x <sup>2</sup>	
50	2	x <sup>2</sup>		x <sup>2</sup>	x <sup>2</sup>	x <sup>2</sup>	
75	2,6	x <sup>2</sup>		x <sup>2</sup>	x <sup>2</sup>	x <sup>2</sup>	
90	3,1	x <sup>2</sup>		x <sup>2</sup>	x <sup>2</sup>	x <sup>2</sup>	
110	3,6	x <sup>2</sup>		x <sup>2</sup>	x <sup>2</sup>	x <sup>1</sup>	
125	4,2	x <sup>2</sup>			x <sup>2</sup>	x <sup>2</sup>	
160	5,2				x <sup>2</sup>		

- 1 optionally with an up to 3 mm thick expanded closed cell polyethylene strip
- 2 optionally with an up to 5 mm thick expanded closed cell polyethylene strip

"System Curaflam Manschette ECO Pro" and "System FS-M R2"

**APPENDIX 2 – FIELD OF APPLICATION**  
Pipe dimensions for pipes of pipe group E ("Silent PP")

Annex 16

### Pipe group F

"Silent dB20"-pipes manufactured by Geberit Vertriebs GmbH, 88630 Pfullendorf, Germany (Z-42.1-265) made from mineral reinforced polyethylene (permissible pipe dimensions for the respective installation conditions are indicated with "x" in the table below)

Wall installation							
d <sub>A</sub> [mm]	s [mm]	EI 90-U/U		EI 90-U/C			
		straight ⊥	straight ⊥	pipe coupling two 45°-pipe elbows	electroweldable pipe sockets		straight ⊥ mortared
					straight ⊥	two 45°-pipe elbows	
56	3,2	x <sup>2</sup>	x <sup>2</sup>		x	x	
63	3,2	x <sup>2</sup>	x <sup>2</sup>			x	
75	3,6	x <sup>2</sup>	x <sup>2</sup>			x	
90	5,5	x <sup>2</sup>	x <sup>2</sup>			x	
110	6,0	x <sup>2</sup>	x <sup>2</sup>	x		x	
135	6,0		x <sup>2</sup>			x	
160	7,0		x		x		
Floor installation							
56	3,2	x <sup>2</sup>	x <sup>2</sup>	x			x <sup>1</sup>
63	3,2	x <sup>2</sup>	x <sup>2</sup>	x			x <sup>1</sup>
75	3,6	x <sup>2</sup>	x <sup>2</sup>	x			x <sup>1</sup>
90	5,5	x <sup>2</sup>	x <sup>2</sup>	x			x <sup>1</sup>
110	6,0	x <sup>2</sup>	x <sup>2</sup>				x <sup>1</sup>
135	6,0		x				x
160	7,0		x				x

1 optionally with an up to 3 mm thick expanded closed cell polyethylene strip

2 optionally with an up to 5 mm thick expanded closed cell polyethylene strip

"System Curaflam Manschette ECO Pro" and "System FS-M R2"

#### APPENDIX 2 – FIELD OF APPLICATION

Pipe dimensions for pipes of pipe group F ("Silent dB20")

Annex 17

### Pipe group G

"POLO-KAL 3S"-pipes manufactured by Poloplast Kunststoffwerk GmbH & Co. KG, 4060 Leonding, Austria (Z-42.1-341) made from mineral reinforced polypropylene (permissible pipe dimensions for the respective installation conditions are indicated with "x" in the table below)

Wall installation							
d <sub>A</sub> [mm]	s [mm]	EI 90-U/U			EI 90-U/C		
		straight ⊥	oblique	two 45°- pipe elbows	straight ⊥	two 45°-pipe elbows	straight ⊥ mortared
75	3,8	x <sup>2</sup>			x <sup>2</sup>		
90	4,5	x <sup>2</sup>			x <sup>2</sup>		
110	4,8	x <sup>2</sup>			x <sup>2</sup>	x <sup>1</sup>	
125	5,3	x <sup>2</sup>			x <sup>2</sup>		
160	7,5	x <sup>2</sup>			x <sup>2</sup>		
Floor installation							
75	3,8	x <sup>1</sup>			x <sup>1</sup>	x <sup>1</sup>	x <sup>1)</sup>
90	4,5	x <sup>1</sup>			x <sup>1</sup>	x <sup>1</sup>	x <sup>1</sup>
110	4,8	x <sup>1</sup>			x <sup>1</sup>	x <sup>1</sup>	x <sup>1)</sup>
125	5,3				x <sup>1</sup>	x <sup>1</sup>	x <sup>1)</sup>
160	7,5				x <sup>1</sup>		

- 1 optionally with an up to 3 mm thick expanded closed cell polyethylene strip
- 2 optionally with an up to 5 mm thick expanded closed cell polyethylene strip
- 3 for installation in walls with a thickness of at least 125 mm; optionally with an up to 5 mm thick expanded closed cell polyethylene strip

"System Curaflam Manschette ECO Pro" and "System FS-M R2"

**APPENDIX 2 – FIELD OF APPLICATION**  
Pipe dimensions for pipes of pipe group G ("POLO-KAL 3S")

Annex 18

## Pipe group H

"POLO-KAL NG"-pipes manufactured by Poloplast Kunststoffwerk GmbH & Co. KG, 4060 Leonding, Austria (Z-42.1-241) made from mineral reinforced polypropylene (permissible pipe dimensions for the respective installation conditions are indicated with "x" in the table below)

Wall installation							
d <sub>A</sub> [mm]	s [mm]	EI 90-U/U			EI 90-U/C		
		straight ⊥	oblique	two 45°- pipe elbows	straight ⊥	two 45°-pipe elbows	straight ⊥ mortared
40	1,8	x <sup>2</sup>			x <sup>2</sup>	x <sup>1</sup>	
50	2,0	x <sup>2</sup>			x <sup>2</sup>	x <sup>1</sup>	
75	2,6	x <sup>2</sup>			x <sup>2</sup>	x <sup>1</sup>	
90	3,0	x <sup>2</sup>			x <sup>2</sup>	x <sup>1</sup>	
110	3,4	x <sup>2</sup>			x <sup>2</sup>	x <sup>1</sup>	
125	3,9	x <sup>2</sup>			x <sup>2</sup>	x <sup>1</sup>	
160	4,9	x <sup>2</sup>			x <sup>2</sup>		
Floor installation							
40	1,8	x <sup>2</sup>		x <sup>2</sup>	x <sup>2</sup>	x <sup>1</sup>	x <sup>1</sup>
50	2,0	x <sup>2</sup>		x <sup>2</sup>	x <sup>2</sup>	x <sup>1</sup>	x <sup>1</sup>
75	2,6	x <sup>2</sup>		x <sup>2</sup>	x <sup>2</sup>	x <sup>1</sup>	x <sup>1</sup>
90	3,0	x <sup>2</sup>		x <sup>2</sup>	x <sup>2</sup>	x <sup>1</sup>	x <sup>1</sup>
110	3,4	x <sup>2</sup>		x <sup>2</sup>	x <sup>2</sup>	x <sup>1</sup>	x <sup>1</sup>
125	3,9	x <sup>2</sup>			x <sup>2</sup>	x <sup>1</sup>	x <sup>1</sup>
160	4,9				x <sup>1</sup>		x <sup>1</sup>

- 1 optionally with an up to 3 mm thick expanded closed cell polyethylene strip
- 2 optionally with an up to 5 mm thick expanded closed cell polyethylene strip
- 3 for installation in rigid walls with a thickness of at least 100 mm; optionally with an up to 5 mm thick expanded closed cell polyethylene strip

"System Curaflam Manschette ECO Pro" and "System FS-M R2"

### APPENDIX 2 – FIELD OF APPLICATION

Pipe dimensions for pipes of pipe group H ("POLO-KAL NG")

Annex 19

### Pipe group I

"Wavin SiTech"-pipes manufactured by Wavin GmbH, 49767 Twist, Germany (Z-42.1-403) made from mineral reinforced polypropylene (permissible pipe dimensions for the respective installation conditions are indicated with "x" in the table below)

Wall installation							
d <sub>A</sub> [mm]	s [mm]	EI 90-U/U			EI 90-U/C		
		straight ⊥	oblique	two 45°- pipe elbows	straight ⊥	two 45°-pipe elbows	straight ⊥ mortared
50	1,8	x <sup>2</sup>			x <sup>2</sup>	x <sup>1</sup>	
75	2,3	x <sup>2</sup>			x <sup>2</sup>	x <sup>1</sup>	
90	2,8	x <sup>2</sup>			x <sup>2</sup>	x <sup>1</sup>	
110	3,4	x <sup>2</sup>			x <sup>2</sup>	x <sup>1</sup>	
125	3,9	x <sup>2</sup>			x <sup>2</sup>	x <sup>1</sup>	
160	4,9	x <sup>2</sup>			x <sup>2</sup>		
Floor installation							
50	1,8	x <sup>2</sup>			x <sup>2</sup>	x <sup>1</sup>	x <sup>1</sup>
75	2,3	x <sup>1</sup>		x <sup>2</sup>	x <sup>1</sup>	x <sup>1</sup>	x <sup>1</sup>
90	2,8	x <sup>1</sup>			x <sup>1</sup>	x <sup>1</sup>	x <sup>1</sup>
110	3,4	x <sup>1</sup>		x <sup>2</sup>	x <sup>1</sup>	x <sup>1</sup>	x <sup>1</sup>
125	3,9	x <sup>1</sup>			x <sup>1</sup>	x <sup>1</sup>	x <sup>1</sup>
160	4,9	x <sup>1</sup>			x <sup>1</sup>		x <sup>1</sup>

- 1 optionally with an up to 3 mm thick expanded closed cell polyethylene strip
- 2 optionally with an up to 5 mm thick expanded closed cell polyethylene strip

"System Curaflam Manschette ECO Pro" and "System FS-M R2"

#### APPENDIX 2 – FIELD OF APPLICATION

Pipe dimensions for pipes of pipe group I ("Wavin SiTech")

Annex 20

### Pipe group J

"BluePower"-pipes manufactured by C.O.E.S., 20096 Pioltello, Italy (Z-42.1-411) made from mineral reinforced polypropylene (permissible pipe dimensions for the respective installation conditions are indicated with "x" in the table below)

Wall installation							
d <sub>A</sub> [mm]	s [mm]	EI 90-U/U			EI 90-U/C		
		straight ⊥	oblique	two 45°- pipe elbows	straight ⊥	two 45°-pipe elbows	straight ⊥ mortared
32	1,8	x <sup>2</sup>			x <sup>2</sup>	x <sup>2</sup>	
40	1,8	x <sup>2</sup>			x <sup>2</sup>	x <sup>2</sup>	
50	1,8	x <sup>2</sup>			x <sup>2</sup>	x <sup>2</sup>	
75	2,3	x <sup>2</sup>			x <sup>2</sup>	x <sup>2</sup>	
90	2,8	x <sup>2</sup>			x <sup>2</sup>	x <sup>2</sup>	
110	3,4	x <sup>2</sup>			x <sup>2</sup>	x <sup>2</sup>	
125	3,9	x <sup>2</sup>			x <sup>2</sup>	x <sup>2</sup>	
160	4,9	x <sup>2</sup>			x <sup>2</sup>		
Floor installation							
32	1,8	x <sup>2</sup>			x <sup>2</sup>	x <sup>2</sup>	x <sup>2</sup>
40	1,8	x <sup>2</sup>			x <sup>2</sup>	x <sup>2</sup>	x <sup>2</sup>
50	1,8	x <sup>2</sup>			x <sup>2</sup>	x <sup>2</sup>	x <sup>2</sup>
75	2,3	x <sup>2</sup>			x <sup>2</sup>	x <sup>2</sup>	x <sup>2</sup>
90	2,8	x <sup>2</sup>			x <sup>2</sup>	x <sup>2</sup>	x <sup>2</sup>
110	3,4	x <sup>2)</sup>			x <sup>2</sup>	x <sup>2</sup>	x <sup>2</sup>
125	3,9				x <sup>2</sup>	x <sup>2</sup>	
160	4,9				x <sup>2</sup>		

- 1 optionally with an up to 3 mm thick expanded closed cell polyethylene strip
- 2 optionally with an up to 5 mm thick expanded closed cell polyethylene strip

"System Curaflam Manschette ECO Pro" and "System FS-M R2"

**APPENDIX 2 – FIELD OF APPLICATION**  
Pipe dimensions for pipes of pipe group J ("Blue Power")

Annex 21

### Pipe group K

"POLO-POLYMUTAN"-pipes according to DIN 8077 manufactured by Poloplast Kunststoffwerk GmbH & Co. KG, 4060 Leonding, Austria made from PP-R 80 (permissible pipe dimensions for the respective installation conditions are indicated with "x" in the table below)

Wall installation							
d <sub>A</sub> [mm]	s [mm]	EI 90-U/U			EI 90-U/C		
		straight ⊥	oblique	two 45°- pipe elbows	straight ⊥	two 45°-pipe elbows	straight ⊥ mortared
32	2,9				x <sup>1</sup>		
40	3,7				x <sup>1</sup>		
50	4,6				x <sup>1</sup>		
63	5,8				x <sup>1</sup>		
75	6,8				x <sup>1</sup>		
90	8,2				x <sup>1</sup>		
110	10 or 18,3				x <sup>1</sup>		
125	11,4 or 20,8				x <sup>1</sup>		
Floor installation							
32	2,9				x <sup>1</sup>		x <sup>1</sup>
40	3,7				x <sup>1</sup>		x <sup>1</sup>
50	4,6				x <sup>1</sup>		x <sup>1</sup>
63	5,8				x <sup>1</sup>		x <sup>1</sup>
75	6,8				x <sup>1</sup>		x <sup>1</sup>
90	8,2				x <sup>1</sup>		x <sup>1</sup>
110	10 or 18,3				x <sup>1</sup>		x <sup>1</sup>
125	11,4 or 20,8				x <sup>1</sup>		x <sup>1</sup>

1 optionally with an up to 5 mm thick expanded closed cell polyethylene strip

"System Curaflam Manschette ECO Pro" and "System FS-M R2"

#### APPENDIX 2 – FIELD OF APPLICATION

Pipe dimensions for pipes of pipe group K ("POLO-POLYMUTAN")

Annex 22

### Pipe group L

Multi-layer composite pipes "Fusiotherm-Stabi-Verbundrohre" manufactured by aquatherm GmbH, 57439 Attendorn, Germany with a support pipe made from polypropylene and a 150 µm thick aluminium layer, which is protected by a thin layer of polypropylene (permissible pipe dimensions for the respective installation conditions are indicated with "x" in the table below)

Wall installation							
d <sub>A</sub> [mm]	s [mm]	EI 90-U/U			EI 90-U/C		
		straight ⊥	oblique	two 45°- pipe elbows	straight ⊥	two 45°-pipe elbows	straight ⊥ mortared
16	3,0				x <sup>2</sup>		
20	3,7				x <sup>2</sup>		
25	4,4				x <sup>2</sup>		
32	5,5				x <sup>2)</sup>		
40	6,6				x <sup>2</sup>		
50	7,9				x <sup>2</sup>		
63	9,7				x <sup>2</sup>		
75	11,4				x <sup>2</sup>		
90	13,5 -13,9				x <sup>2</sup>		
110	16,7 -17,2				x <sup>2</sup>		
floor installation							
16	3,0				x <sup>1</sup>		
20	3,7				x <sup>1</sup>		
25	4,4				x <sup>1</sup>		
32	5,5				x <sup>1</sup>		
40	6,6				x <sup>1</sup>		
50	7,9				x <sup>1</sup>		
63	9,7				x <sup>1</sup>		
75	11,4				x <sup>1</sup>		
90	13,5 -13,9				x <sup>1</sup>		
110	16,7 -17,2				x <sup>1</sup>		

1 optionally with an up to 3 mm thick expanded closed cell polyethylene strip

2 optionally with an up to 5 mm thick expanded closed cell polyethylene strip

"System Curaflam Manschette ECO Pro" and "System FS-M R2"

#### APPENDIX 2 – FIELD OF APPLICATION

Pipe dimensions for pipes of pipe group L ("Fusiotherm-Stabi-Verbundrohre")

Annex 23



## INSTALLATION OF THE PENETRATION SEAL

### 1. General

- 1.1 Before installing the penetration seal it shall be checked that all conditions (e. g. type and thickness of the wall or floor, type and dimensions of the pipes and insulation and the ambient conditions) comply with the provisions of Section 1.2 and Appendices 1 and 2.
- 1.2 It shall be ensured that the assumptions under which the fitness for use was evaluated are complied with (see Section 4.1).

### 2. Selection of pipe collars

- 2.1 The smallest pipe collar assigned to the relevant external pipe diameter according to Annex 1 shall be used.
- 2.2 Deviating from section 2.1 it is allowed to use pipe collars of the size DN 110 and DN 125 on two or three non insulated pipes of pipe group A or B according to Annex 1 – each with a maximum pipe diameter of 63 mm and a pipe wall thickness between 1.8 mm and 4.7 mm.
- 2.3 Deviating from section 2.1 pipe collars shall be used on pipes with two 45°elbows, which are two steps larger in size than the smallest pipe collar assigned to the relevant external pipe diameter (see Annexes 6 and 9). In case of wall installation this size shall be used on both sides of the wall.

### 3. Arrangement of pipe collars

- 3.1 For pipe penetrations in floors, one pipe collar shall be fitted at the underside of the floor. For pipe penetrations in walls one pipe collar shall be fitted on each side of the wall (see Appendix 1).
- 3.2 The pipe collars shall be mounted on the surface of the walls and floors according to the information given in Annexes 5 to 10.

The fixing straps shall be fixed to the wall or floor using appropriate screws and/or anchors or threaded rods. Deviating from this, the fixing straps of the collar may be mortared in case of floor installation (see Annex 10; so-called "partially mortared" collars).

- 3.3 Deviating from section 3.2 the following shall apply: In case of floor installation the collars may be cast ("mortared") into the floor (see Annex 10), depending on the pipe material and the pipe dimensions (see Annexes 12 to 28).

### 4. Fixing

#### 4.1 Closure of pipe collars

- 4.1.1 The pipe collars selected according to chapter 2.1 shall be placed around the pipe in the area of the penetration and shall be closed using the hook-shaped strap and – if collars with variable size (see Annex 3) were used – the cut-outs of the "first latch".

"System Curaflam Manschette ECO Pro" and "System FS-M R2"

### APPENDIX 3 – INSTALLATION OF THE PENETRATION SEAL

Annex 24

4.1.2 In case of installing pipe collars on 45° elbows according to Appendix 2, the collar shall be bent open ovally, so that the collar installed lies closely to the pipe on one side and that a gap of a maximum width of 15 mm remains between pipe and collar on the opposite side (see Annexes 5 to 10).

#### 4.2 Fixing of surface mounted pipe collars and closing remaining gaps

4.2.1 The surface mounted pipe collars shall be fixed to rigid walls or floors via their fixing lugs with adequate steel screws and – if appropriate – with adequate anchors (each with a diameter of 8 mm). The number of fasteners shall comply with the number of fixing straps (depending on the size of the collar according to the provisions of Annexes 2 and 4).

When fixing the collars with anchors the required edge distances shall be observed.

4.2.2 The pipe collars shall be fixed to flexible walls with continuous threaded bolts (with a diameter of 8 mm); this type of fixing may also be used for rigid building elements.

4.2.3 Prior to the installation of the pipe collars the remaining gap between the wall or floor and the penetrating pipe (insulation included) shall be filled completely over the entire building element's thickness with a dimensionally stable non-combustible material (class A1 or A2-s1,d0 according to EN 13501-1), as e. g. concrete, cementitious or gypsum mortar (see Annexes 5 to 10).

4.2.4 Deviating from section 4.2.3 the following shall apply: When installing pipe collars on straight pipes penetrated the building element rectangular without PE foam insulation, a gap between the building element and the penetrating pipe of 15 mm width at the most may tightly be plugged with non-combustible mineral wool of a melting point of at least 1000°C according to DIN 4102-17.

#### 4.3 Fixing of incast pipe collars and closing remaining gaps

4.3.1 When installing in floors the fixing straps of the pipe collar may be mortared (so-called "partially mortared" collars). For that purpose the straps shall be angled at the casing by 90° in the direction of the wall of the collar. At the end of the fixing straps a 1.5 cm long section shall additionally be angled outwards by 90° (see Annex 10).

The straps shall be completely mortared, so that there will be no gap between floor and collar. All remaining gaps between pipe, fixing straps and building element shall tightly be closed according to chapter 4.3.3.

4.3.2 Where appropriate the pipe collars may also be completely mortared when installed in floors (see Annexes 12 to 28). For that purpose the straps shall be angled at the casing by 90° in the direction of the wall of the collar (see Annex 10). The remaining gaps between pipe and building element as well as between pipe collar and building element shall tightly be closed according to chapter 4.3.3.

4.3.3 The remaining gaps between floor and penetrating pipe (insulation included) as well as between floor and fixing straps or pipe collar shall be filled completely over the entire building element's thickness with a dimensionally stable non-combustible material (class A1 or A2-s1,d0 according to EN 13501-1), as e. g. concrete, cementitious or gypsum mortar (see Annex 10).

"System Curaflam Manschette ECO Pro" and "System FS-M R2"

#### APPENDIX 3 – INSTALLATION OF THE PENETRATION SEAL

Annex 25

**Example for CE marking**

 XXXX
DOYMA GmbH & Co Industriestraße 43-57 28876 Oyten  Germany  11  XXXX-CPD-XXXX
ETA-13/0910 ETAG 026 – Teil 2 Rohrabschottung / Penetration Seal "Curaflam System ECO <sup>Pro</sup> "  Rohrmanschette / Pipe collar "Curaflam ECO <sup>Pro</sup> "  use category Y <sub>2</sub>

"CE"-Zeichen / "CE" marking

Identifizierungsnummer der notifizierten Stelle (für Konformitätsbescheinigungssystem 1) / Identification number of notified certification body

Name und Anschrift des Herstellers oder seines autorisierten Vertreters (verantwortliche juristische Person) / Name and address of the producer (legal entity responsible for the manufacturer)

Die letzten beiden Ziffern des Jahres, in dem die CE-Kennzeichnung angebracht wurde / Two last digits of year of affixing CE marking

Nummer des EG-Konformitätszertifikats (für Konformitätsbescheinigungssystem 1) / Number of EC certificate of conformity

Nummer der ETA / ETA number

Nummer der Leitlinie / ETAG number

Produktbezeichnung (Handelsname) / Designation of the product (trade name)

Produktbezeichnung der Komponente (Handelsname) / Designation of the component (trade name)

Nutzungskategorie / use category

Für weitere relevante Produktmerkmale (z. B. Feuerwiderstandsklasse, Abgabe gefährlicher Stoffe) s. ETA-13/0910 / See ETA-13/0910 for other relevant characteristics (i. e. fire resistance class, dangerous substances)

"System Curaflam Manschette ECO Pro" and "System FS-M R2"

**APPENDIX 4 – EXAMPLE FOR CE MARKING AND ADDITIONAL INFORMATIONS**

Annex 26

### Abbreviations

- FWKL:** maximum fire resistance class; If installed in building elements of the same type, thickness, density and with the same structure, but with a lower fire resistance class, the fire resistance class of the pipe penetration seal is reduced to the fire resistance class of the building element.
- LTW:** flexible wall according to Annex 6
- MW:** rigid wall according to Annex 6
- D:** rigid floor according to Annex 6
- d<sub>w</sub>:** thickness of the wall
- d<sub>f</sub>:** thickness of the floor
- d<sub>A</sub>:** outer pipe diameter (nominal diameter according to the standards)
- s:** pipe wall thickness (nominal value according to the standards)
- c:** thickness of the flexible PE-foam strip
- ⊥:** perpendicular to the surface of the building element

### Standards

- EN 13501-2:2010-02** Fire classification of construction products and building elements – Part 2: Classification using test data from resistance to fire tests, excluding ventilation services
- EN 13501-1:2007** Fire classification of construction products and building elements – Part 1: Classification using test data from reaction to fire tests
- prEN 1366-3:2007-07** Document from CEN TC 127 for formal vote (document N 185); title see EN 1366-3:2009-07
- EN 1366-3:2009-07** Fire resistance tests for service installations – Part 3: Penetration seals
- DIN 4102-17:1990-12** Brandverhalten von Baustoffen und Bauteilen; Schmelzpunkt von Mineralfaser-Dämmstoffen; Begriffe, Anforderungen, Prüfung
- DIN 8077:** Rohre aus Polypropylen (PP); PP-H 100, PP-B 80, PP-R 80; Maße

### Other Documents

- ETAG 026-2 Guideline for European Technical Approval of Fire Stopping and Fire Sealing Products, Part 2, Penetration Seals (edition January 2008)
- EOTA TR 024 Characterisation, Aspects of Durability and Factory Production Control for Reactive Materials, Components and Products (edition November 2006)

"System Curaflam Manschette ECO Pro" and "System FS-M R2"

### **APPENDIX 5 – ABBREVIATIONS AND REFERENCE DOCUMENTS**

Annex 27