

Approval body for construction products
and types of construction

Bautechnisches Prüfamt

An institution established by the Federal and
Laender Governments



European Technical Assessment

ETA-07/0105
of 27 April 2018

English translation prepared by DIBt - Original version in German language

General Part

Technical Assessment Body issuing the
European Technical Assessment:

Deutsches Institut für Bautechnik

Trade name of the construction product

ARGISOL

Product family
to which the construction product belongs

Non load bearing shuttering kit "ARGISOL" based
on shuttering elements of EPS

Manufacturer

BIOISOTHERM S.r.l.
via Roma, n. 14
20045 BESANA IN BRIANZA (MILANO)
ITALIEN

Manufacturing plant

L'ISOLANTE S.r.l. - II° plant -
Strada Statale 249 Nord, n.4
46048 Roverbella (MN)
ITALIEN

RI.BA SUD S.r.l.
via Bosco Fili - Z. I.
84091 Battipaglia (SA)
ITALIEN

This European Technical Assessment
contains

45 pages including 37 annexes which form an integral
part of this assessment

This European Technical Assessment is
issued in accordance with Regulation (EU)
No 305/2011, on the basis of

ETAG 009,
used as EAD according to Article 66 Paragraph 3 of
Regulation (EU) No 305/2011.

This version replaces

ETA-07/0105 issued on 23 April 2013

**European Technical Assessment
ETA-07/0105**

Page 2 of 45 | 27 April 2018

English translation prepared by DIBt

The European Technical Assessment is issued by the Technical Assessment Body in its official language. Translations of this European Technical Assessment in other languages shall fully correspond to the original issued document and shall be identified as such.

Communication of this European Technical Assessment, including transmission by electronic means, shall be in full. However, partial reproduction may only be made with the written consent of the issuing Technical Assessment Body. Any partial reproduction shall be identified as such.

This European Technical Assessment may be withdrawn by the issuing Technical Assessment Body, in particular pursuant to information by the Commission in accordance with Article 25(3) of Regulation (EU) No 305/2011.

Specific Part

1 Technical description of the product

1.1 Definition of construction product

The shuttering system "ARGISOL" is a non load-bearing permanent shuttering kit based on standard shuttering elements, accessory parts and special shuttering elements (see Annexes A2 to A4) applicable as formwork for plain and reinforced concrete walls cast in-situ.

The accessory parts are wedges for horizontal curved walls, single plates, pieces for the equalization of differences in height and end stops.

1.2 Shuttering elements

1.2.1 Standard shuttering elements

The standard shuttering elements (see Annexes A2.1, A3.1, A3.9 and A4.1) consist of inner and outer shuttering leaves of expanded polystyrene (EPS shuttering leaves) and steel sheets used as spacers. The spacers are 0.5 mm thick and connect the shuttering leaves. The distance between the spacers in longitudinal direction for the shuttering elements with 14 cm thickness of concrete core is 125 mm (see e. g. Annex A2.1) and for the shuttering elements with 16.5 and 21.5 cm of thickness of concrete core is 150 mm (see e. g. Annexes A3.1 and A4.1). The standard shuttering elements are assembled by foaming (factory-made) steel spacers into the inner and outer EPS shuttering leaves.

The top and the bottom of each EPS shuttering leaf incorporate an interlocking arrangement to form a tight joint (see Annexes A2.1, A3.1, A3.9 and A4.1).

The surfaces are generally smooth. There are also tapered vertical grooves on the inside and outside face of each EPS shuttering leaf. These element-high dovetail grooves on the inside face provide a mechanical interlock between EPS shuttering leaves and concrete core (see clause 3.4.1) and additionally form locks for end stops.

The vertical ends of the EPS shuttering leaves are tongue and groove joints and form a tight joint. Sealing foam is used to seal these vertical joints, where required, and to fill in gaps caused by inaccuracy of foundation level to between any of the formed joints.

The dimensions of the standard shuttering elements are given in Table A1.

1.2.2 Special shuttering elements

Special elements are also part of the kit as corner elements, angular elements, T-elements, elements with hinges for horizontal curved walls and lintel elements which are produced in the same manner as described above.

1.3 Accessory parts

1.3.1 Wedges for horizontal curved walls (Annex A2.5)

Wedges are as high as the shuttering leaves (250 mm) and are used to fill the gaps between the vertical joints on the inner side of the horizontal curved walls.

1.3.2 **Single leaves, pieces for the equalization of differences in height, end stops (EPS or wood) and wood support edges (Annexes A2.6, A3.10 and A4.7)**

The top and the bottom of these accessory parts incorporate an interlocking arrangement to form a tight joint as well as element-high dovetail grooves on the inside and outside face of each EPS shuttering leaf in the same manner as the EPS shuttering leaves of the standard shuttering elements described above, see clause 1.2.1. The vertical ends of these EPS shuttering leaves are tongue and groove joints and form a tight junction.

Single leaves and pieces for equalization are provided to fill gaps between connections of shuttering elements (e. g. roof connection). Single leaves are additionally used in the ceiling level as a vertical shuttering part and to avoid heat bridges in end use conditions. For this purpose the single leaves are fixed to resist the pressure of fresh concrete of the ceilings when the concrete core of the wall has sufficiently hardened. The dimensions of the single leaves are equivalent to the dimensions of the EPS shuttering leaves. The length and the height of pieces for the equalization of differences in height are varying dependent on the thickness of the concrete core.

End stops are used to lock walls at the end of the EPS shuttering leaves at wall openings. The dimensions of end stops are varying dependent on the thickness of the concrete core and of the material (expanded polystyrene or wood).

The length of the wood support edges is in all cases 48 cm, the height is 2,5 cm and the width is 5 cm.

2 **Specification of the intended use in accordance with the applicable European Assessment Document**

The kit is intended to be used for construction of internal walls as well as external walls above or below ground which are load-bearing (structural) or non-load-bearing (nonstructural), including those which are subjected to fire regulations.

When using this type of construction below ground a waterproofing according to applicable national rules shall be provided depending on whether water not exerting pressure or water exerting pressure is to be dealt with. The waterproofing shall be protected from mechanical damage by a smash-resistant protective layer.

The performances given in Section 3 are only valid if the shuttering elements are used in compliance with the specifications and conditions given in Annex B.

The verifications and assessment methods on which this European Technical Assessment is based lead to the assumption of a working life of the shuttering kit of at least 50 years. The indications given on the working life cannot be interpreted as a guarantee given by the producer, but are to be regarded only as a means for choosing the right products in relation to the expected economically reasonable working life of the works.

3 **Performance of the product and references to the methods used for its assessment**

3.1 **Mechanical resistance and stability (BWR 1)**

3.1.1 **Resulting structural pattern**

In end use conditions walls made with shuttering elements "ARGISOL" are walls of a continuous type according to ETAG 009, clause 2.2.

3.1.2 **Efficiency of filling**

Considering the instructions of Annex B1 and the installation guide of the manufacturer an efficient filling without bursting of the shuttering and without voids or any uncovered reinforcement in the concrete core is possible.

The requirements according to ETAG 009, clause 6.1.2 are met satisfactorily.

English translation prepared by DIBt

3.1.3 Possibility of steel reinforcement

The instructions in the installation guide of the manufacturer are appropriate to install steel reinforcement for walls according to EN 1992-1-1 or corresponding national rules.

The requirements according to ETAG 009, clause 6.1.3 are met satisfactorily.

3.2 Safety in case of fire (BWR 2)

3.2.1 Reaction to fire

Shuttering elements "ARGISOL" made of expanded polystyrene (EPS) fulfil the requirement of Class E according to EN 13501-1.

3.3 Hygiene, health and the environment (BWR 3)

3.3.1 Release of dangerous substances

Essential characteristic	Performance
Contents of dangerous substances	The product does not contain CMR-substances actively used (in accordance with Regulation (EC) No 1272/2008) and no HBCDD.
Release scenario regarding BWR 3: IA2	

3.3.2 Water vapour permeability

The tabulated design value of the water vapour resistance factor of expanded polystyrene (EPS) according to EN ISO 10456 is $\mu = 60$.

The values of the water vapour resistance factor of concrete depending on type and density are tabulated in EN ISO 10456.

Using these values the verification of the annual moisture balance or the maximum amount of interstitial condensation according to EN ISO 13788 will be on the safe side.

3.3.3 Water absorption

As given in the designation code "WL(T)5" of the EPS (see Annex A1 below Table A1) the long term water absorption by total immersion W_{it} of the EPS shuttering leaves shall not exceed 5,0 %, according to EN 13163.

The requirements according to ETAG 009, clause 6.3.3 are met satisfactorily.

3.3.4 Watertightness

Because finishes are not part of the shuttering system "ARGISOL" the "No performance assessed" option in ETAG 009, Table 3 is used.

3.4 Safety and accessibility in use (BWR 4)

3.4.1 Bond strength between the shuttering leaves and the concrete core

Under end use conditions the EPS shuttering leaves are durable fixed by the steel spacers. The bond strength is at least equal to the resisting pressure of fresh concrete of the EPS shuttering leaves, see clause 3.4.2, furthermore the vertical element-high dovetail grooves on the inside face of each EPS shuttering leaf provide a mechanical interlock between EPS shuttering leaves and concrete core.

Concrete walls (without consideration of the finishes), constructed with shuttering system "ARGISOL" and designed according EN 1992-1-1 respectively in lack of availability of EN 1992-1-1 according national design rules, lead to the assumption that concrete core insures an adequate resistance of the complete wall to normal use impact loads.

The requirements according to ETAG 009, clause 6.4.1 are met satisfactorily.

3.4.2 Resistance to filling pressure

To resist the pressure of fresh concrete the bending tensile strength of the EPS shuttering leaves shall be more than 150 kPa, see designation code "BS150" of EPS (see Annex A1 below Table A1).

The tensile strength of the steel spacers shall be at least 360 MPa. The pull-out strength between steel spacers and the EPS shuttering leaves shall be at least 850 N.

The requirements according to ETAG 009, clause 6.4.2 are met satisfactorily.

3.4.3 Safety against personal injury by contact

Delivered on site the shuttering elements do not have sharp or cutting edges.

Because of the soft surface of the EPS shuttering leaves there is no risk of abrasion or of cutting people.

The requirements according to ETAG 009, clause 6.4.3 are met satisfactorily.

3.5 Protection against noise (BWR 5)

3.5.1 Airborne sound insulation

The "No performance assessed" option in ETAG 009, Table 3 is used.

3.5.2 Sound absorption

The "No performance assessed" option in ETAG 009, table 3 is used.

3.6 Energy economy and heat retention (BWR 6)

3.6.1 Thermal resistance

The declared value of thermal resistance $R_{D,element}$ of the shuttering elements in end use conditions (see Annex B6, with concrete core without rendering) is the sum of the declared value of thermal resistance of the EPS shuttering leaves $R_{D,EPS}$ and the concrete core $R_{D,concrete}$. The declared value of thermal resistance of the EPS shuttering leaves $R_{D,EPS}$ shall be calculated in accordance with EN ISO 6946 with a declared value of thermal conductivity of the EPS shuttering leaves of $\lambda = 0.031 \text{ W/(m}\times\text{K)}$ according to EN 13163, clause 4.2.1 and the declared value of thermal resistance of the concrete core $R_{D,concrete}$ shall be calculated in accordance with EN ISO 6946 with a value of thermal conductivity λ of the concrete core depending on the density ρ tabulated in EN ISO 10456 and considering the influence of the steel spacers by a reduction factor, see Table 1, according to the influence of the thickness of the EPS shuttering leaves.

Table 1: Reduction factor

Type	Thickness of EPS shuttering leaves		Reduction factor
	inner leaf	outer leaf	
	[mm]	[mm]	
25/14.0	48	62	0,80
30/14.0	48	112	0,80
35/14.0	48	162	0,90
30/16.5	62	73	0,80
35/16.5	62	123	0,80
40/16.5	62	173	0,90
35/21.5	62	73	0,80
40/21.5	62	123	0,80
45/21.5	62	173	0,90

The planner shall consider the metal parts of the system as thermal bridges, where relevant, for determination of the declared value of thermal resistance $R_{D,element}$.

3.6.2 Influence of moisture transfer on insulating capacity of the wall

Using the values of clause 3.3.2 the verification of the annual moisture balance or the maximum amount of interstitial condensation according to EN ISO 13788 will be on the safe side.

3.6.3 Heat capacity

The values of the heat capacity of concrete and expanded polystyrene are tabulated in EN ISO 10456.

3.7 General Aspects

3.7.1 Resistance to deterioration

Physical agent

As given in the designation code "DS(N)2" of the EPS (see Annex A1 below Table A1) the relative changes of the EPS shuttering leaves in length and width under constant normal laboratory conditions (23 °C, 50 % relative humidity) shall not exceed $\pm 0,2$ %, according to EN 13163.

The requirements according to ETAG 009, clause 6.7.1.1 are met satisfactorily.

Chemical agent

The steel spacers are only necessary for the resistance to pressure of fresh concrete. When the concrete core has sufficiently hardened the bond between concrete core and EPS shuttering leaves is given by the vertical dovetail grooves on the inside face of each EPS shuttering leaf (see clause 3.4.1).

The finishes of the wall are not part of the ETA. Determination of the cleaning agent of the surface is not possible.

The requirements according to ETAG 009, clause 6.7.1.2 are met satisfactorily.

Biological agent

The application of EPS as thermal insulation material for decades has shown that it is sufficiently protected against fungi, bacteria, algae and insects.

EPS does not provide a food value and in general it does not contain voids suitable for habitation by vermin.

The shuttering system "ARGISOL" does not contain any biocides.

The requirements according to ETAG 009, clause 6.7.1.3 are met satisfactorily.

3.7.2 Resistance to normal use damage

Normal use impacts

Concrete walls (without consideration of the finishes), constructed with shuttering system "ARGISOL" and designed according EN 1992-1-1 respectively in lack of availability of EN 1992-1-1 according national design rules, lead to the assumption that concrete core insures an adequate resistance of the complete wall under normal used impact loads.

The requirements according to ETAG 009, clause 6.7.2.1 are met satisfactorily.

Incorporation of ducts

The instructions in the installation guide of the manufacturer are appropriate to produce horizontal perforations through the walls, which are necessary for passing through ducts, see Annex B1, clause 4.

The requirements according to ETAG 009, clause 6.7.2.2 are met satisfactorily.

Fixing of objects

Fixing of objects in the EPS shuttering leaves is not possible. The part of fixings which is significant for the mechanical resistance shall be inside the concrete core.

The requirements according to ETAG 009, clause 6.7.2.3 are met satisfactorily.

4 Assessment and verification of constancy of performance (AVCP) system applied, with reference to its legal base

In accordance with guideline for European technical approval ETAG 009, June 2002, used as European Assessment Document (EAD) according to Article 66 Paragraph 3 of Regulation (EU) No 305/2011, the applicable European legal act is: [98/279/EC], as amended by European legal act [2001/596/EC]

The system to be applied is: 2+

5 Technical details necessary for the implementation of the AVCP system, as provided for in the applicable EAD

Technical details necessary for the implementation of the AVCP system are laid down in the control plan deposited with Deutsches Institut für Bautechnik.

Issued in Berlin on 27 April 2018 by Deutsches Institut für Bautechnik

BD Dipl.-Ing. Andreas Kummerow
Head of Department

beglaubigt:
Dr.-Ing. Alex

Characteristics of shuttering elements

The shuttering kit "ARGISOL" consists of the following elements:

- standard shuttering elements,
- special shuttering elements and
- accessory parts.

see clauses 1., 2. and 3.

1. Standard shuttering elements

The standard shuttering elements (composed of EPS shuttering leaves and steel spacers) correspond to the information and drawings given in Annexes A2.1, A3.1, A3.9 and A4.1.

The following types of standard shuttering elements are available:

Table A1: Wall thicknesses of the EPS standard shuttering elements

Type	according Annex	Thickness of the wall	Thickness of concrete core	EPS shuttering leaves				Longitudinal centre distance of steel spacers
				Thickness		Height	Length	
				inner	outer			
[mm]	[mm]	[mm]	[mm]	[mm]	[mm]	[mm]		
25/14.0	A2.1	250	140	48	62	250	1000	125
30/14.0		300	140	48	112	250	1000	125
35/14.0		350	140	48	162	250	1000	125
30/16.5	A3.1 A3.9	300	165	62	73	230	1200	150
						300		
35/16.5		350	165	62	123	230	1200	150
						300		
40/16.5		400	165	62	173	230	1200	150
						300		
35/21.5	A4.1	350	215	62	73	300	1200	150
40/21.5		400	215	62	123	300	1200	150
45/21.5		450	215	62	173	300	1200	150

The EPS shuttering leaves are made of expanded polystyrene (EPS) EPS-EN 13163-T(1)-L(2)-W(2)-S(2)-P(5)-BS150-CS(10)100-DS(N)2-TR100-WL(T)5 according to EN 13163 composed of polystyrene particle foam with graphite.

The density ρ of the expanded polystyrene is in the range between 25 kg/m³ and 30 kg/m³.

The declared value of thermal conductivity of the expanded polystyrene is 0,031 W/(m×K).

ARGISOL

Standard shuttering elements – 14 cm

Anhang A1
Page 1 of 2

The nominal thickness of the spacers made of galvanized steel (steel spacers, see e.g. Annexes A2.1, A3.1, A3.9 and A4.1) is 0.50 mm and the minimum height in the middle of the steel spacers is 50 mm.

The material characteristics, dimensions and tolerances of the standard shuttering elements not indicated in Annexes A2.1, A3.1, A3.9 and A4.1 are given in the technical documentation¹ of the ETA.

2. Special shuttering elements

The special shuttering elements correspond to the information and drawings given in Annexes A2.2 to A2.5, Annexes A3.2 to A3.8 and Annexes A4.2 to A4.6. The special shuttering elements are:

- T elements,
- terminal window elements,
- lintel elements,
- corner elements 90°,
- curved corner elements,
- corner elements 45°,
- 90° opposite angular elements and
- elements with hinges for horizontal curved walls.

Special shuttering elements are designed in the same manner as the standard shuttering elements described above, see clause 1.

The special shuttering elements consist of EPS and steel spacers, it is the same material used for standard shuttering elements specified in clause 1.

3. Accessory parts

The accessory parts correspond to the information and drawings given in Annexes A2.5, A2.6, A3.10 and A4.7. The accessory parts are:

- wedges for horizontal curved walls,
- single leaves,
- pieces for the equalization of differences in height,
- end stops (EPS or wood) and
- wood support edges.

The accessory parts consist of EPS, it is the same material used for standard shuttering elements specified in clause 1.

¹ The technical documentation of the ETA is deposited with *Deutsches Institut für Bautechnik* and, as far as relevant for the tasks of the approved bodies involved in the attestation of conformity procedure, is handed over to the approved bodies.

ARGISOL

Standard shuttering elements – 14 cm

Anhang A2
Page 2 of 2

Standard shuttering element 25/14.0

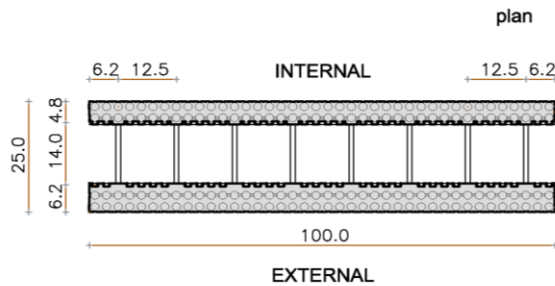

Dimension standard shuttering element 25/14.0 (100x25x25)

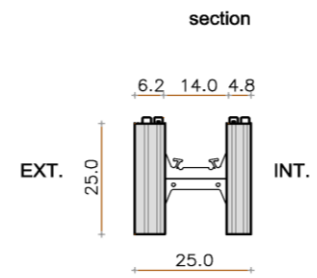

Standard shuttering element 30/14.0

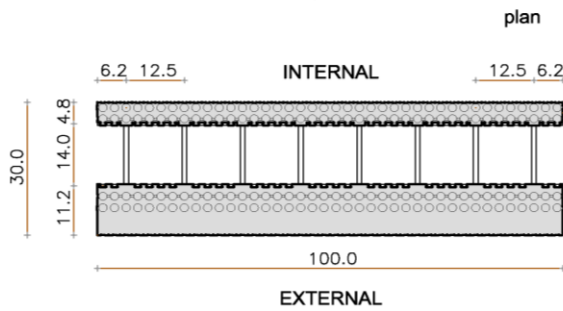

Dimension standard shuttering element 30/14.0 (100x30x25)

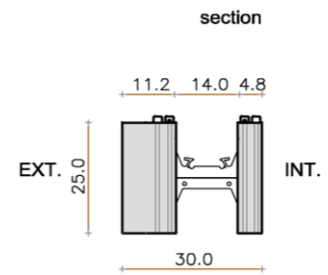

Standard shuttering element 35/14.0

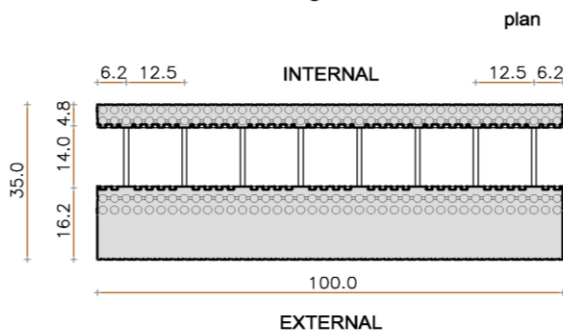

Dimension standard shuttering element 25/14.0 (100x35x25)

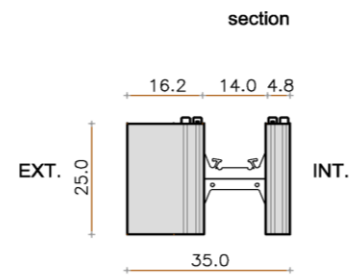

all dimensions in cm

ARGISOL

Standard shuttering elements – 14 cm

Anhang A2.1

"T" element 25/14.0

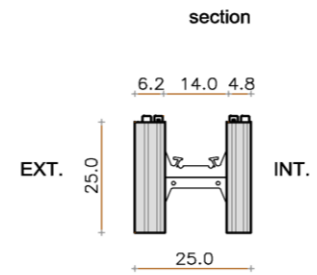
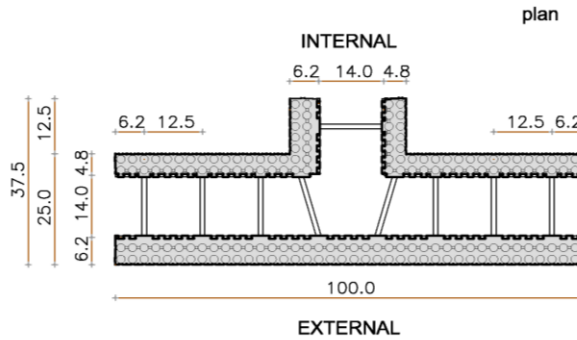

Dimension "T" element 25/14.0 (100-37.5x25x25)

"T" element 25/14.0

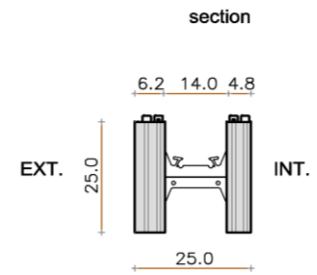
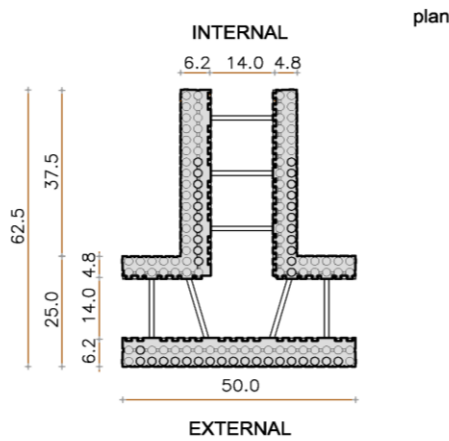

Dimension "T" element 25/14.0 (50-62.5x25x25)

all dimensions in cm

ARGISOL

Special shuttering elements – 14 cm
T elements

Anhang A2.2

Terminal window element 25/14.0 plan

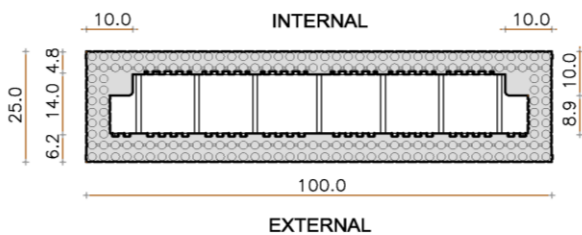

Dimension terminal window element 25/14.0 (100x25x25)

section

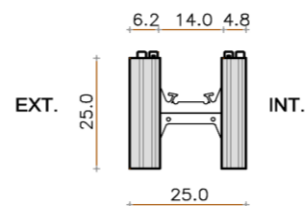

Lintel element 25/14.0 plan

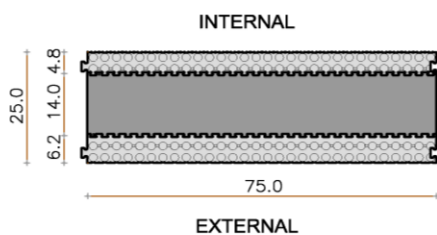

Dimension lintel element 25/14.0 (75x25x25)

section

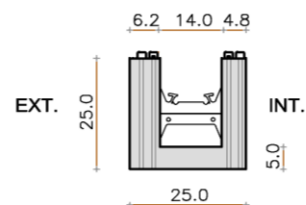

all dimensions in cm

ARGISOL

Special shuttering elements – 14 cm
Terminal window elements
Lintel elements

Anhang A2.3

Corner shuttering element 25/14.0 plan

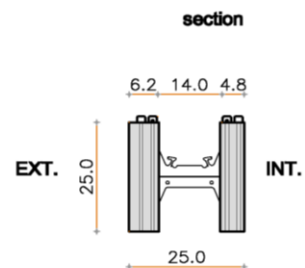
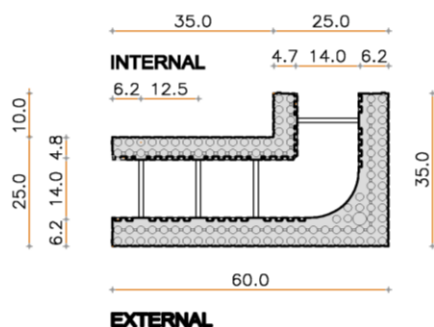

Dimension corner shuttering element 25/14.0 (60-35)x25x25

Corner shuttering element 30/14.0 plan

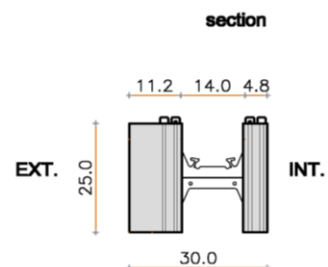
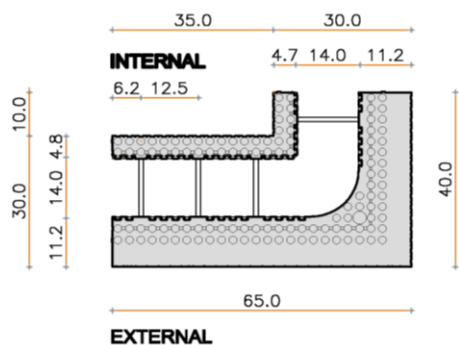

Dimension corner shuttering element 30/14.0 (65-40)x30x25

Corner shuttering element 35/14.0 plan

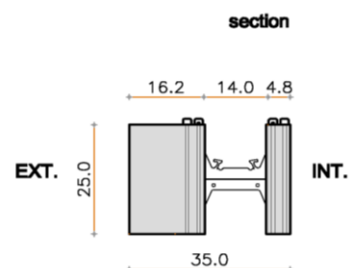
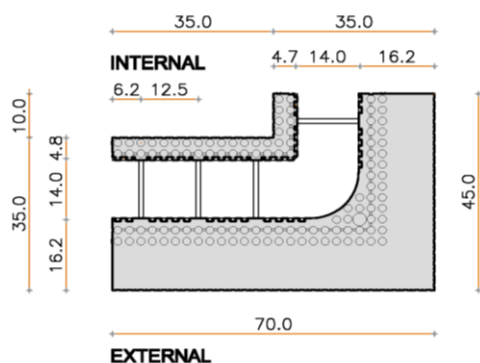

Dimension corner shuttering element 35/14.0 (70-45)x35x25

all dimensions in cm

electronic copy of the eta by dibt: eta-07/0105

ARGISOL

Special shuttering elements – 14 cm
Corner elements

Anhang A2.4

Curved corner element plan

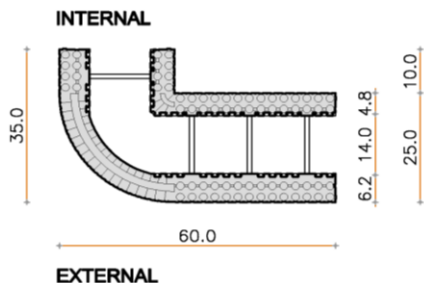

Dimension curved corner element 25/14.0 (60-35)x25x25

section

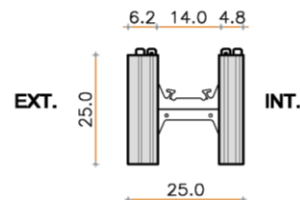

Corner element 45° plan

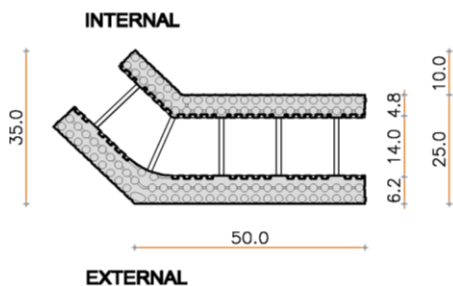

Dimension corner element 45° 25/14.0 (50-35)x25x25

section

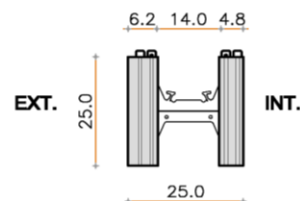

Element with hinges for horizontal curved walls 30/14.0

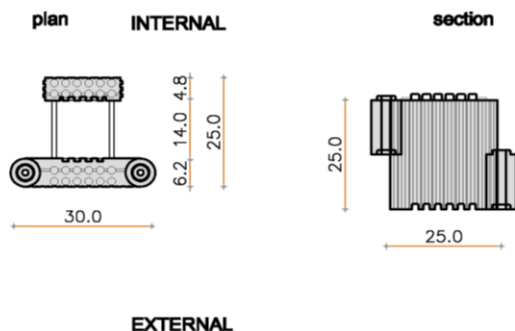

Dimension element with hinges for horizontal curved walls 25/14.0 (30x25x25)

Wedges

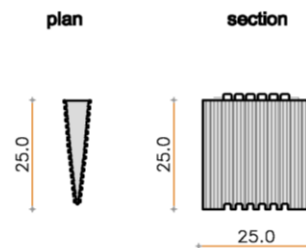

all dimensions in cm

electronic copy of the eta by dibt: eta-07/0105

ARGISOL

Special shuttering elements – 14 cm
Curved corner elements / Corner elements 45°
Elements with hinges for horizontal curved walls / Wedges for horizontal curved walls

Anhang A2.5

Pieces for the equalization of differences in height

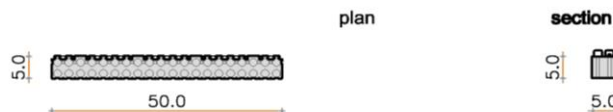

Dimension pieces for the equalization of differences in height 5.0 (50x5x5)

Single plates 6.2

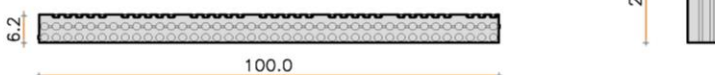

Dimension single plates 6.2 (100x6.2x25)

Single plates 11.2

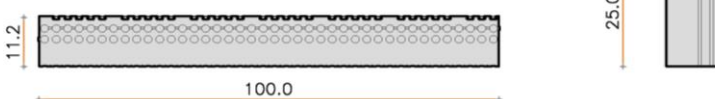

Dimension single plates 11.2 (100x11.2x25)

Single plates 16.2

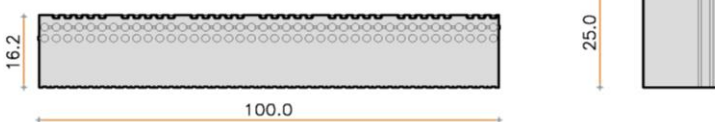

Dimension single plates 16.2 (100x16.2x25)

Wood support edge

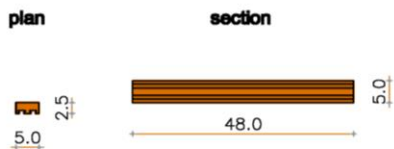

End stops wood

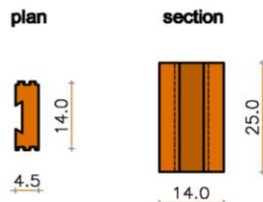

End stops EPS

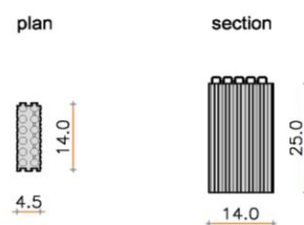

all dimensions in cm

ARGISOL

Accessory parts – 14 cm
Pieces for the equalization of differences in height / Single leaves
Wood support edges / End stops (wood or EPS)

Anhang A2.6

Standard shuttering element 30/16.5

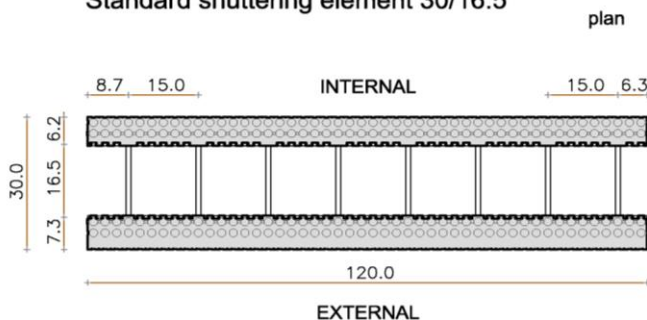

Dimension standard shuttering element 30/16.5 (120x30x30)

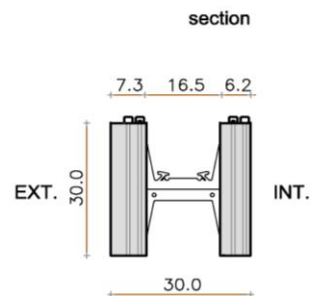

Standard shuttering element 35/16.5

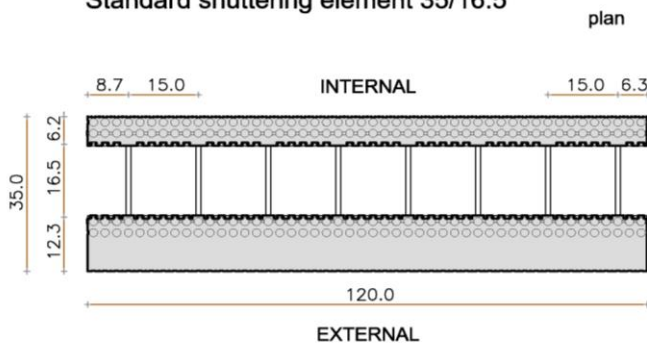

Dimension standard shuttering element 35/16.5 (120x35x30)

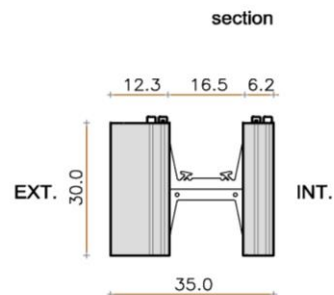

Standard shuttering element 40/16.5

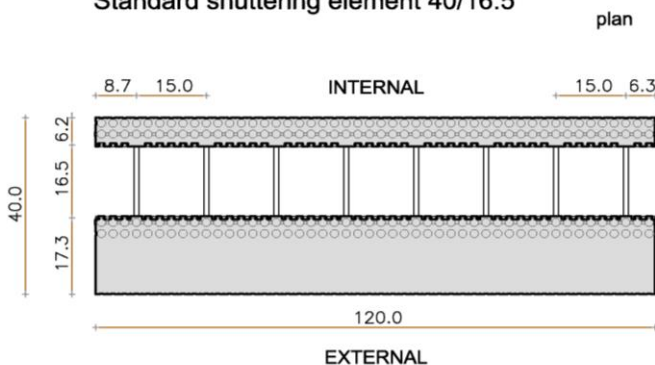

Dimension standard shuttering element 40/16.5 (120x40x30)

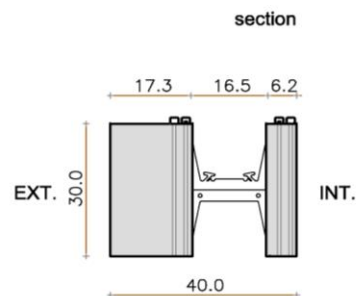

all dimensions in cm

ARGISOL

Standard shuttering elements – 16,5 cm, h = 30 cm

Anhang A3.1

"T" element 30/16.5

plan

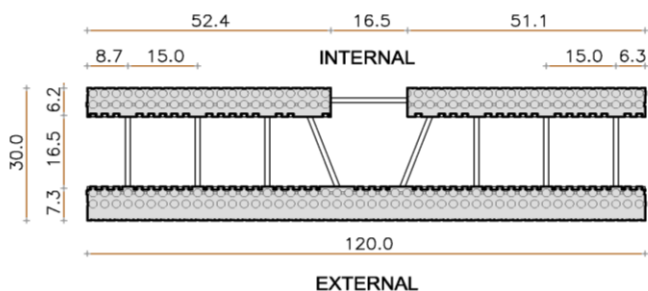

section

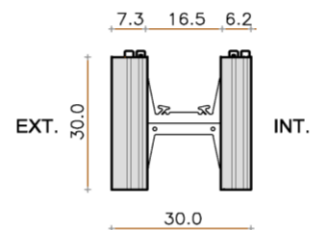

Dimension "T" element 30/16.5 (120x30x30)

"T" element 35/16.5

plan

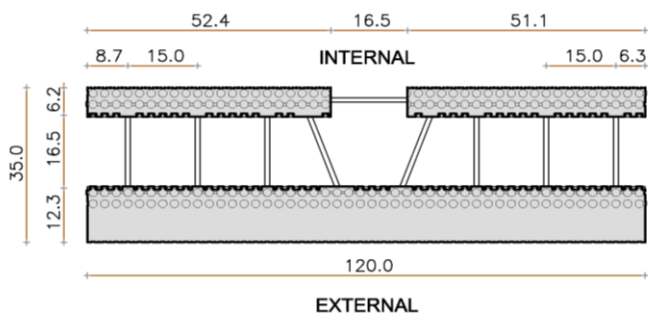

section

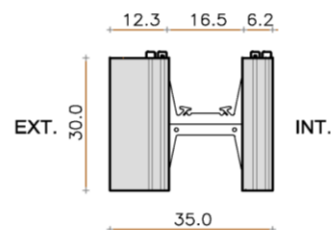

Dimension "T" element 35/16.5 (120x35x30)

"T" element 40/16.5

plan

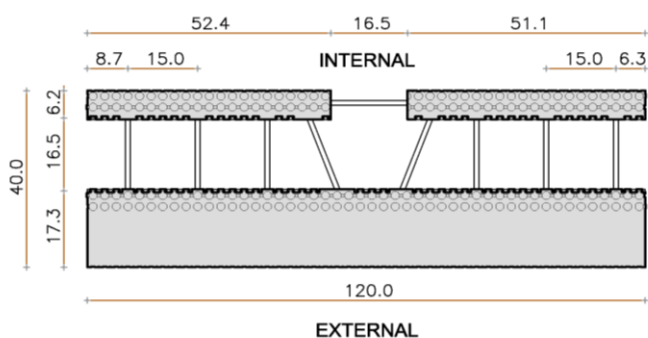

section

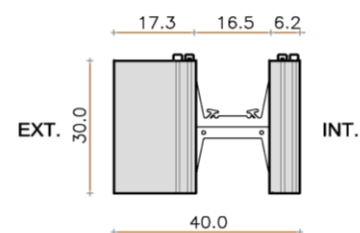

Dimension "T" element 40/16.5 (120x40x30)

all dimensions in cm

ARGISOL

Special shuttering elements – 16,5 cm
T elements

Anhang A3.2

Terminal window element 30/16.5

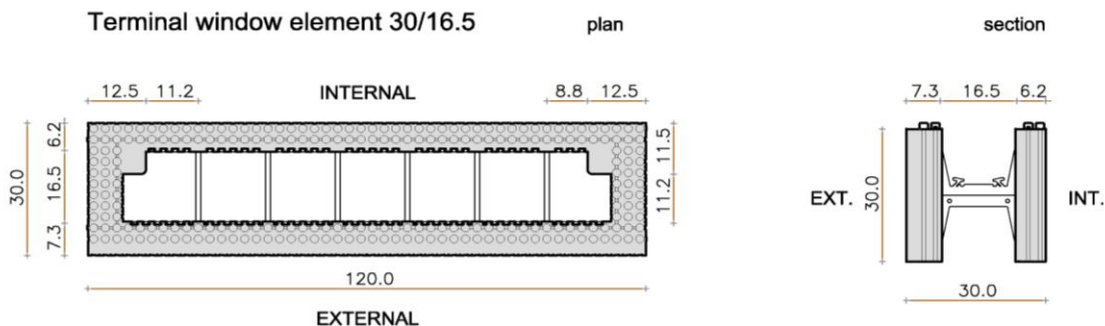

Dimension terminal window element 30/16.5 (120x30x30)

Terminal window element 35/16.5

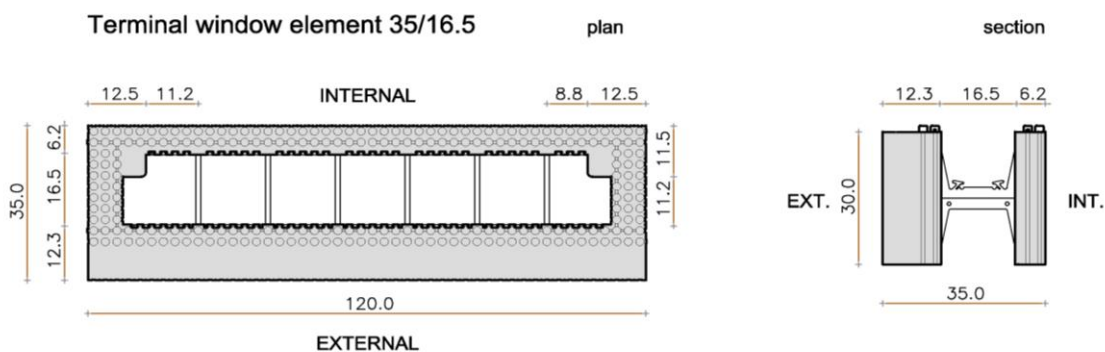

Dimension terminal window element 35/16.5 (120x35x30)

Terminal window element 40/16.5

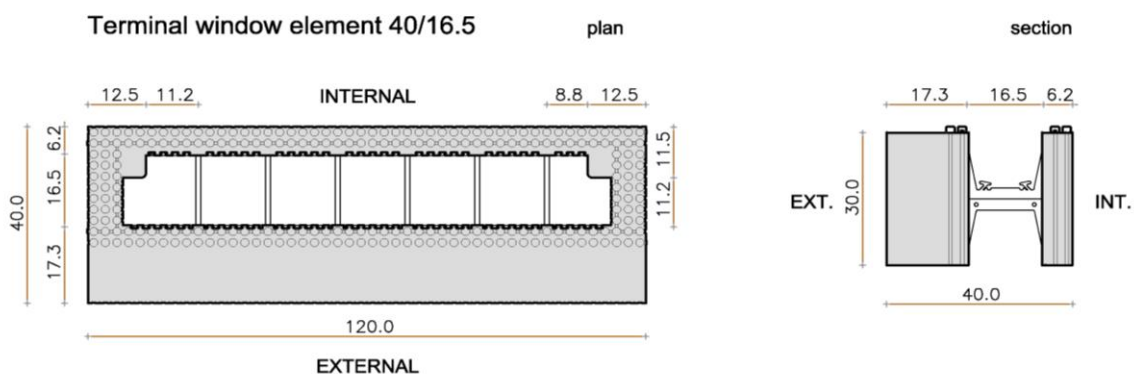

Dimension terminal window element 40/16.5 (120x40x30)

all dimensions in cm

ARGISOL

Special shuttering elements – 16,5 cm
Terminal window elements

Anhang A3.3

Lintel element 30/16.5 plan

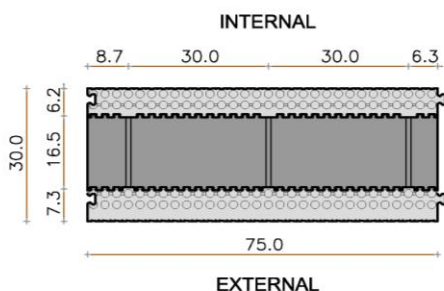

Dimension lintel element 30/16.5 (75x30x30)

section

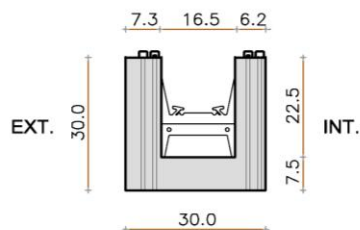

Lintel element 35/16.5 plan

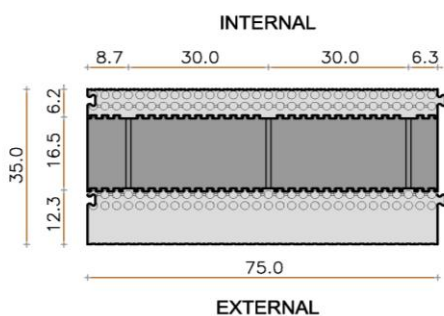

Dimension lintel element 35/16.5 (75x35x30)

section

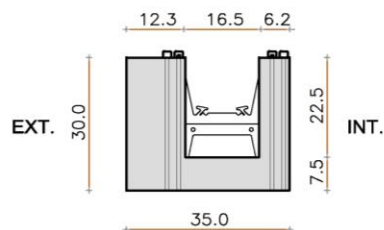

Lintel element 40/16.5 plan

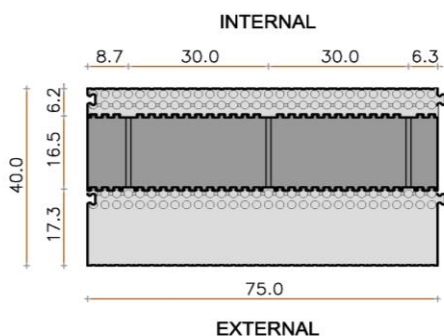

Dimension lintel element 40/16.5 (75x40x30)

section

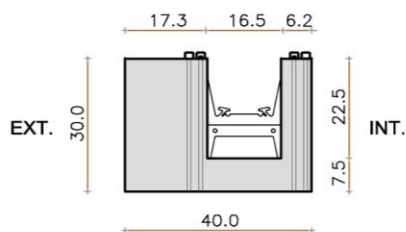

all dimensions in cm

ARGISOL

Special shuttering elements – 16,5 cm
Lintel elements

Anhang A3.4

Corner shuttering element 30/16.5 plan

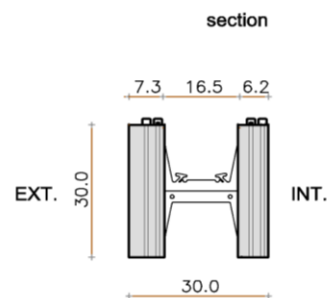
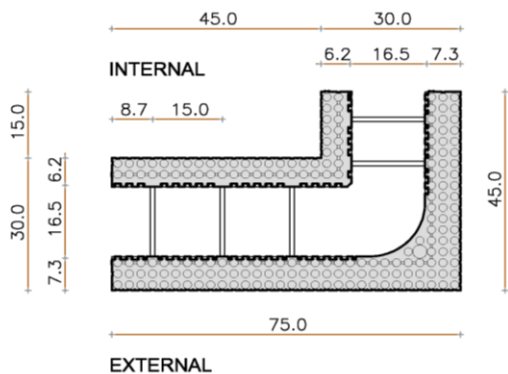

Dimension corner shuttering element 30/16.5 (45-75)x30x30

Corner shuttering element 35/16.5 plan

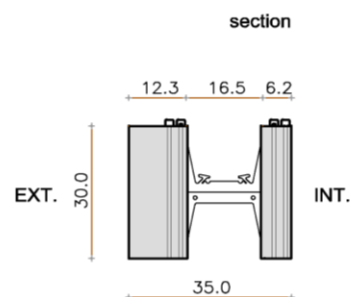
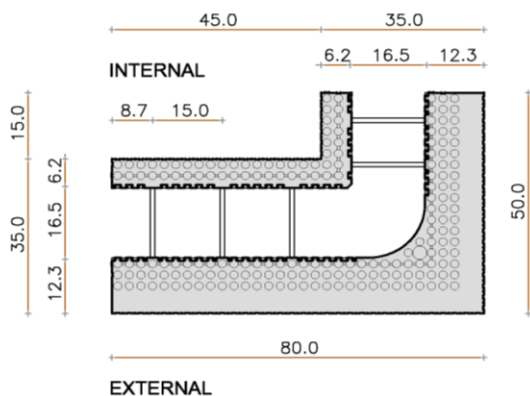

Dimension corner shuttering element 35/16.5 (50-80)x35x30

Corner shuttering element 40/16.5 plan

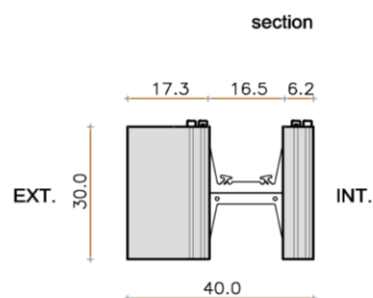
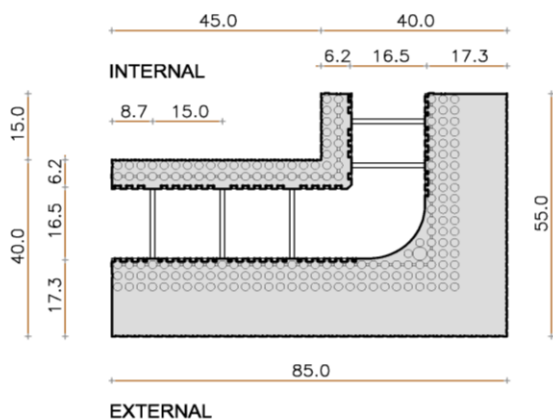

Dimension corner shuttering element 40/16.5 (55-85)x40x30

all dimensions in cm

electronic copy of the eta by dibt: eta-07/0105

ARGISOL

Special shuttering elements – 16,5 cm
Corner elements, h = 30 cm

Anhang A3.5

Corner shuttering element 30/16.5 - h. 23

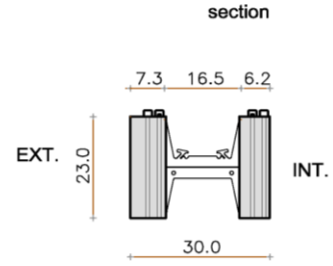
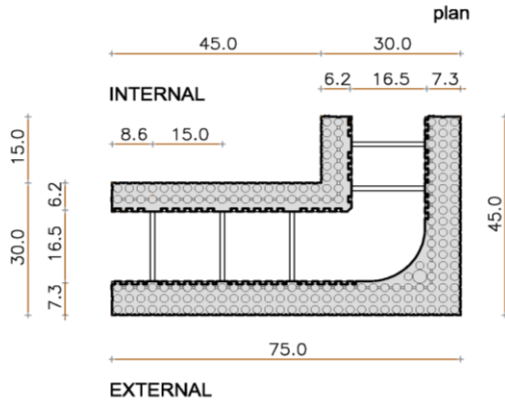

Dimension corner shuttering element 30/16.5 (45-75)x30x23

Corner shuttering element 35/16.5 - h. 23

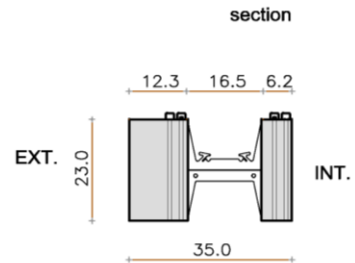
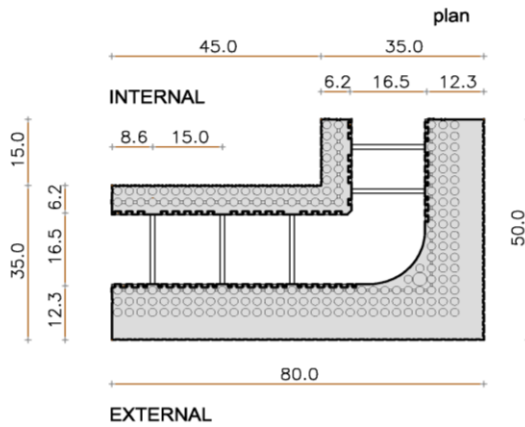

Dimension corner shuttering element 35/16.5 (50-80)x35x23

Corner shuttering element 40/16.5 - h. 23

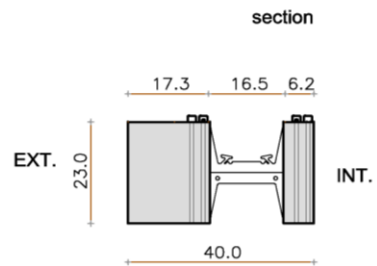
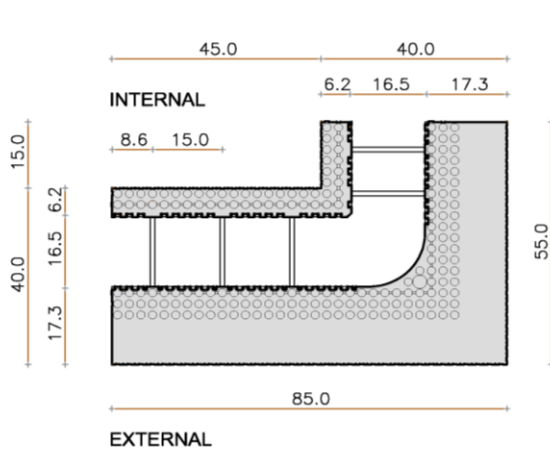

Dimension corner shuttering element 40/16.5 (55-85)x40x23

all dimensions in cm

ARGISOL

Special shuttering elements – 16,5 cm
Corner elements, h = 23 cm

Anhang A3.6

90° opposite angular shuttering element 35/16.5

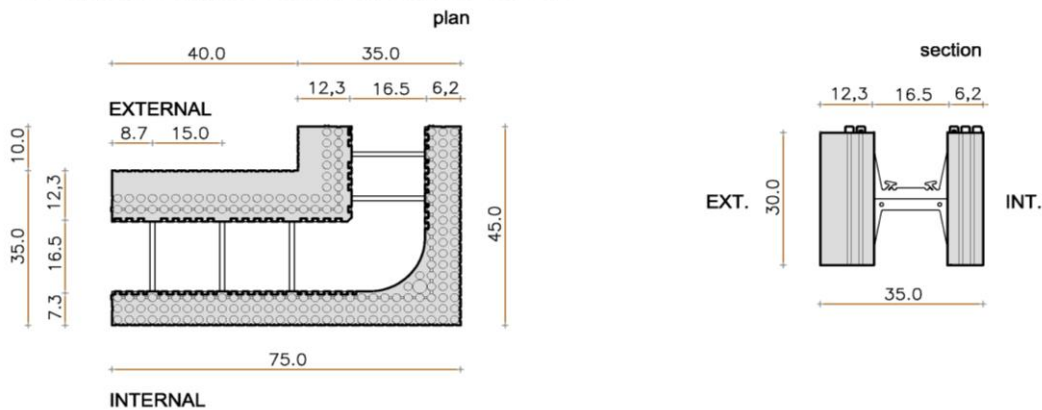

Dimension 90° opposite angular shuttering element 35/16.5 (45-75)x35x30

90° opposite angular shuttering element 40/16.5

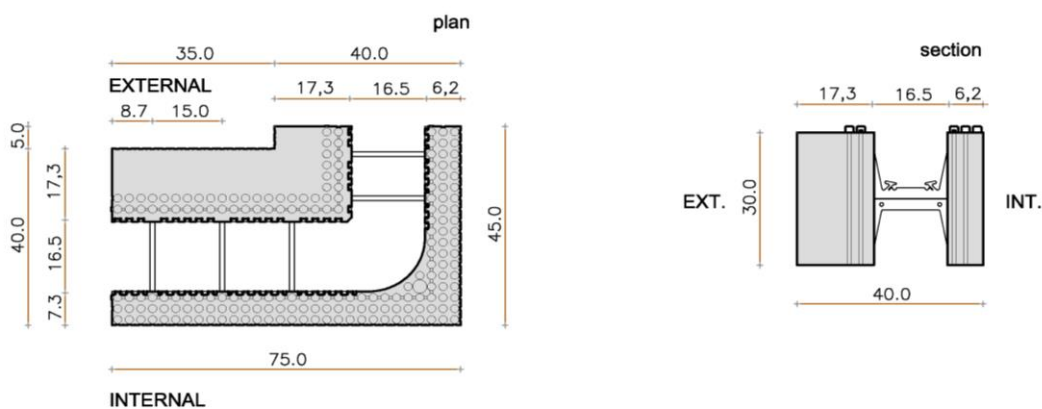

Dimension 90° opposite angular shuttering element 40/16.5 (45-75)x40x30

all dimensions in cm

ARGISOL

Special shuttering elements – 16,5 cm
90° opposite angular elements, h = 30 cm

Anhang A3.7

90° opposite angular shuttering element 35/16.5 - h. 23

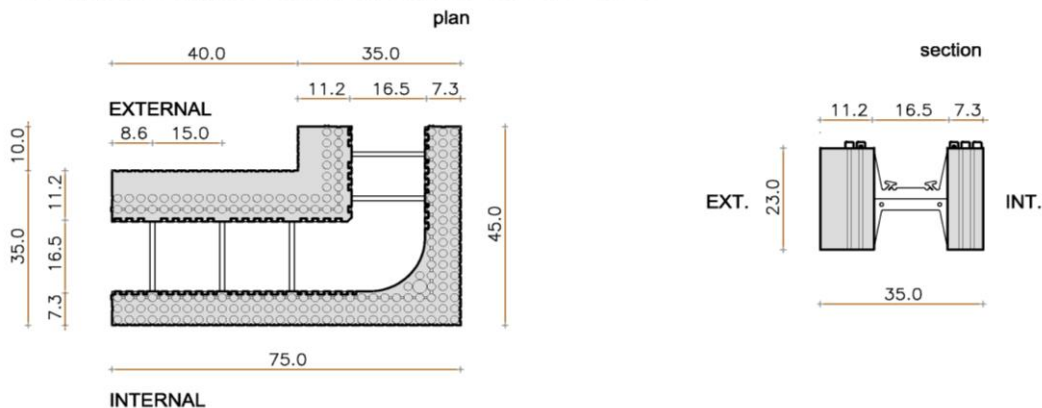

Dimension 90° opposite angular shuttering element 35/16.5 (45-75)x35x23

90° opposite angular shuttering element 40/16.5 - h. 23

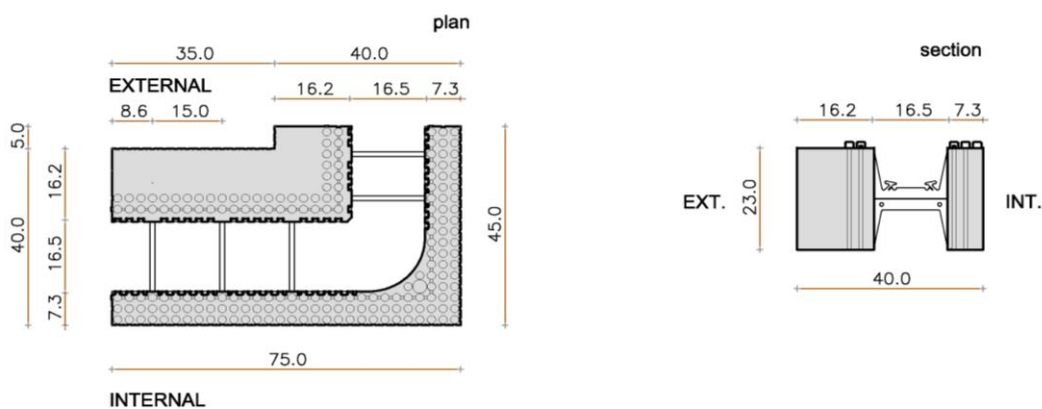

Dimension 90° opposite angular shuttering element 40/16.5 (45-75)x40x23

all dimensions in cm

ARGISOL

Special shuttering elements – 16,5 cm
90° opposite angular elements, h = 23 cm

Anhang A3.8

Standard shuttering element 30/16.5 - H=23

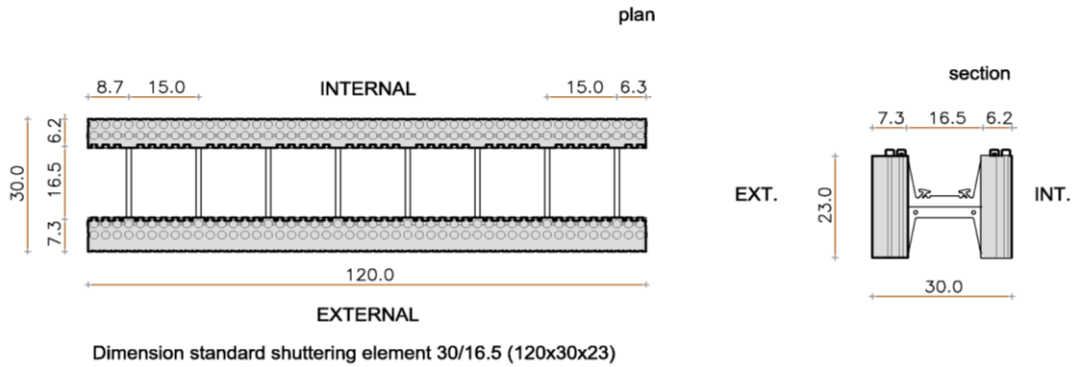

Standard shuttering element 35/16.5 - H=23

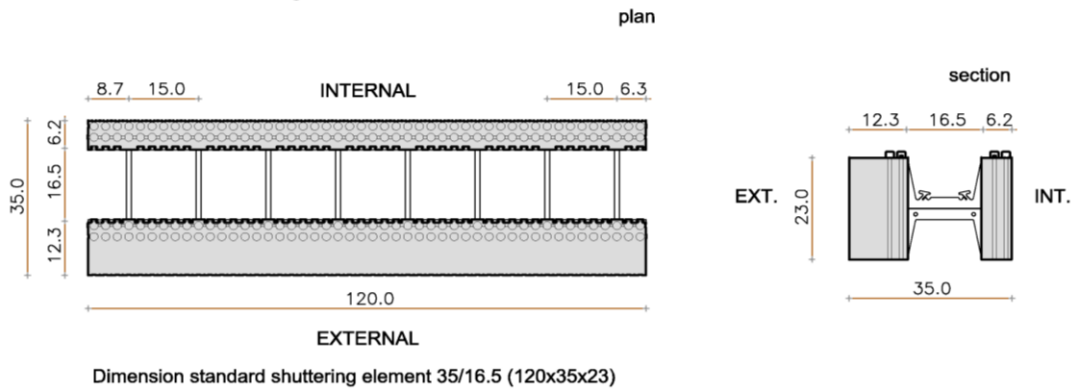

Standard shuttering element 40/16.5 - H=23

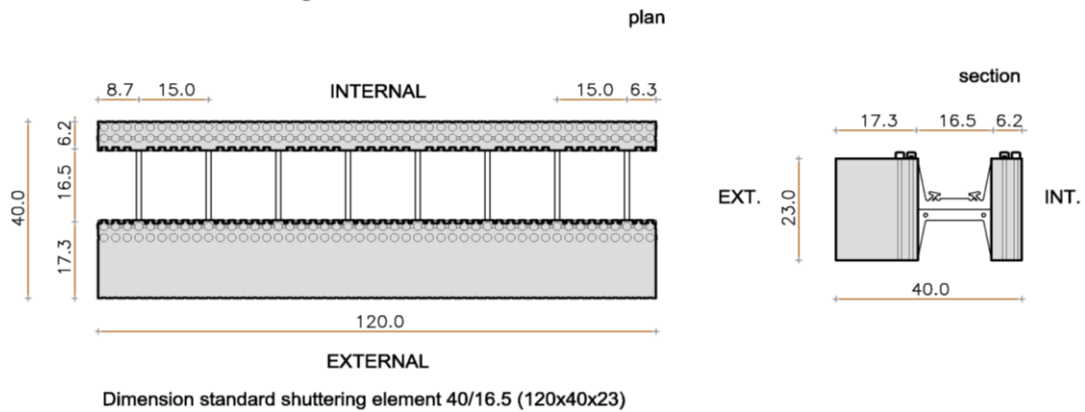

all dimensions in cm

ARGISOL

Standard shuttering elements – 16,5 cm, h = 23 cm

Anhang A3.9

Pieces for the equalization of differences in height - $l=6.2$

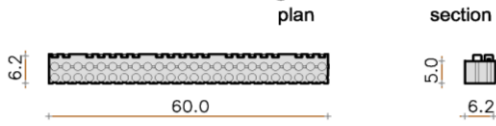

Dimension pieces for the equalization of differences in height - $l=6.2$ (50x6.2x5)

Single Plates 6.2

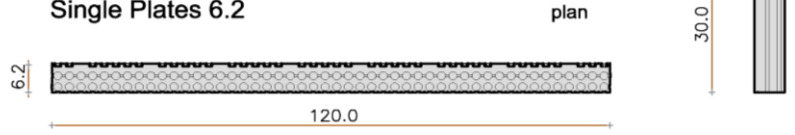

Dimension single plates 6.2 (120x6.2x30)

Pieces for the equalization of differences in height - $l=7.3$

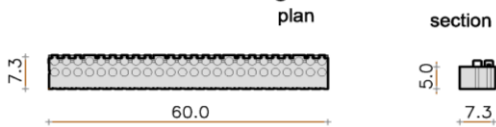

Dimension pieces for the equalization of differences in height - $l=7.3$ (50x7.3x5)

Single Plates 7.3

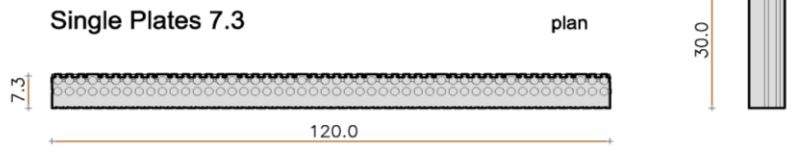

Dimension single plates 7.3 (120x7.3x30)

Pieces for the equalization of differences in height - $l=12.3$

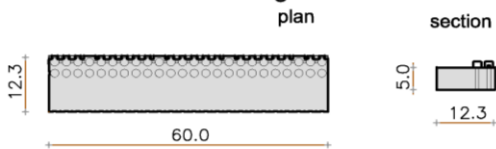

Dimension pieces for the equalization of differences in height - $l=12.3$ (50x12.3x5)

Single Plates 12.3

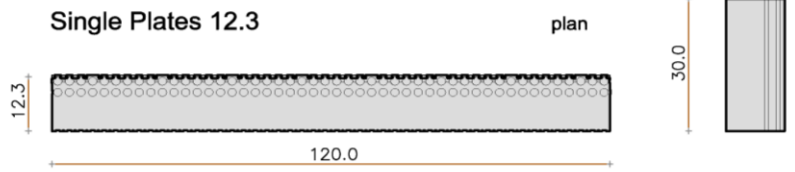

Dimension single plates 12.3 (120x12.3x30)

Pieces for the equalization of differences in height - $l=17.3$

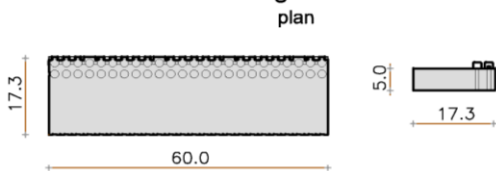

Dimension pieces for the equalization of differences in height - $l=17.3$ (50x17.3x5)

Single Plates 17.3

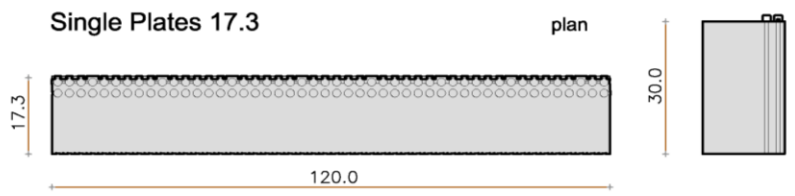

Dimension single plates 17.3 (120x17.3x30)

Wood Support Edge

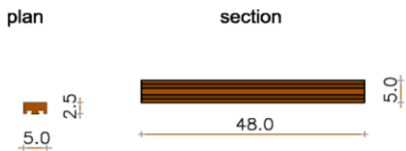

End Stops Wood

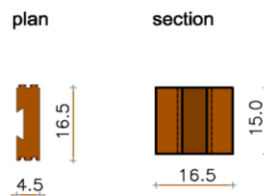

End Stops EPS

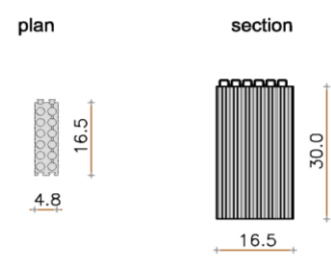

all dimensions in cm

ARGISOL

Accessory parts – 16,5 cm
Pieces for the equalization of differences in height / Single leaves
Wood support edges / End stops (wood or EPS)

Anhang A3.10

Standard shuttering element 35/21.5

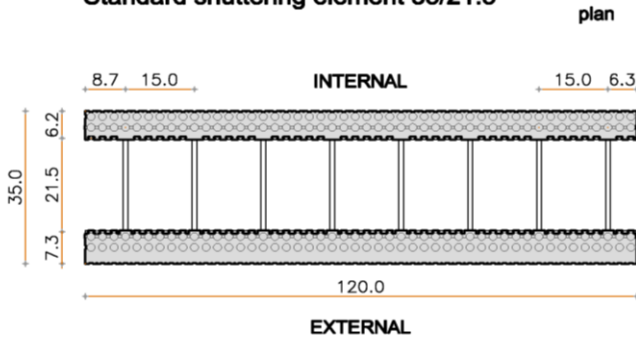

Dimension standard shuttering element 35/21.5 (120x35x30)

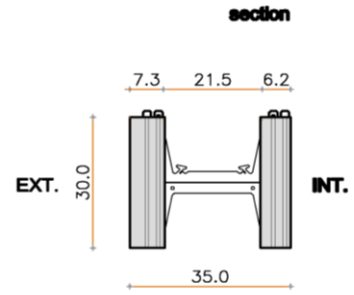

Standard shuttering element 40/21.5

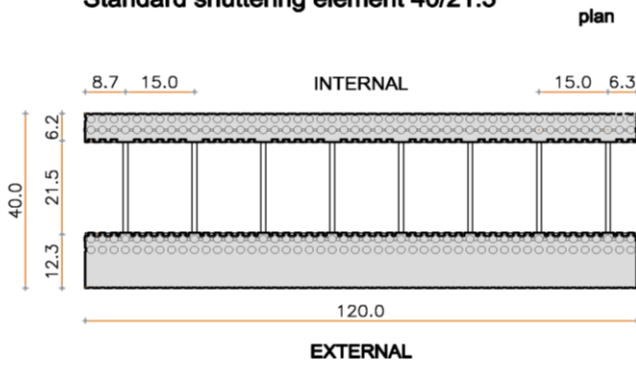

Dimension standard shuttering element 40/21.5 (120x40x30)

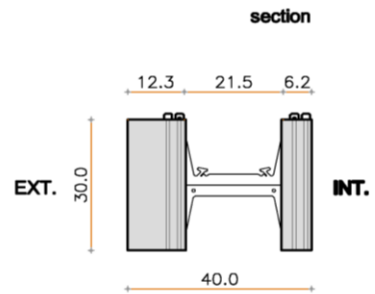

Standard shuttering element 45/21.5

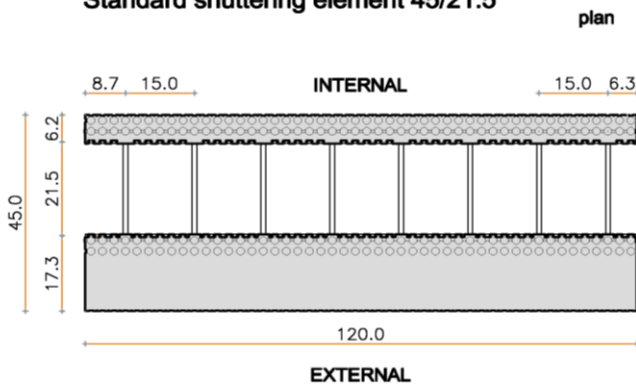

Dimension standard shuttering element 45/21.5 (120x45x30)

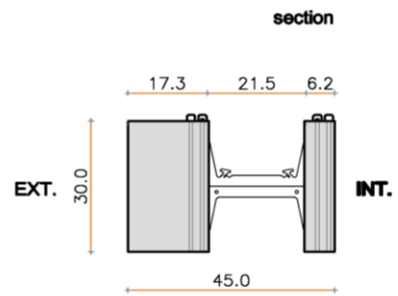

all dimensions in cm

electronic copy of the eta by dibt: eta-07/0105

ARGISOL

Standard shuttering elements – 21,5 cm

Anhang A4.1

"T" element 35/21.5

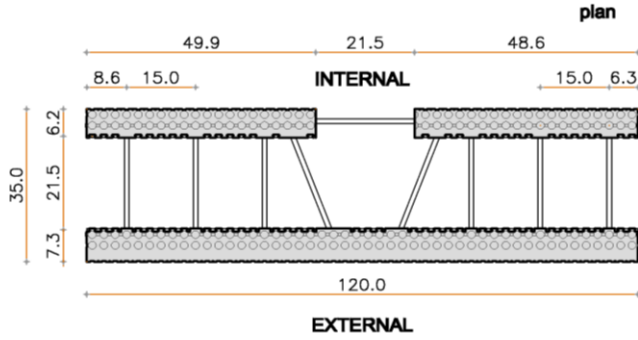

Dimension "T" element 35/21.5 (120x35x30)

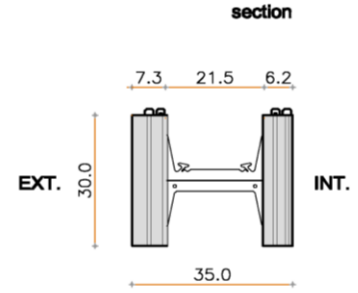

"T" element 40/21.5

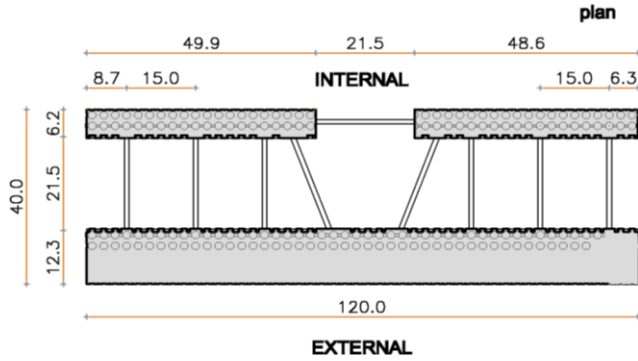

Dimension "T" element 40/21.5 (120x40x30)

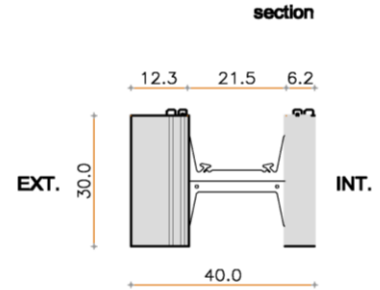

"T" element 45/21.5

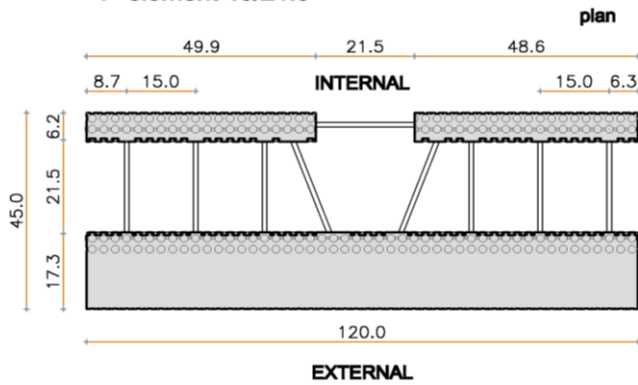

Dimension "T" element 45/21.5 (120x45x30)

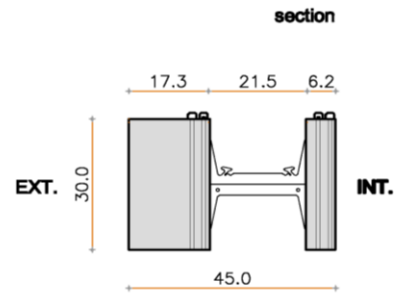

all dimensions in cm

electronic copy of the eta by dibt: eta-07/0105

ARGISOL

Special shuttering elements – 21,5 cm
 T elements

Anhang A4.2

Terminal window element 35/21.5

plan

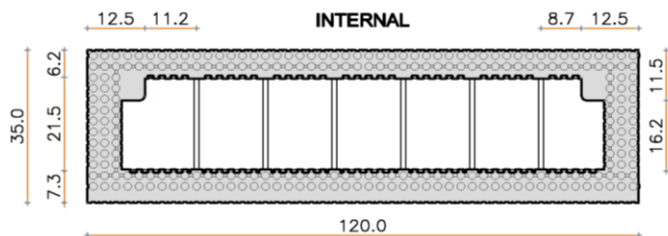

Dimension terminal window element 35/21.5 (120x35x30)

section

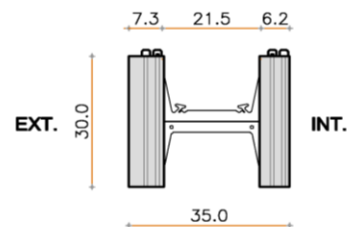

Terminal window element 40/21.5

plan

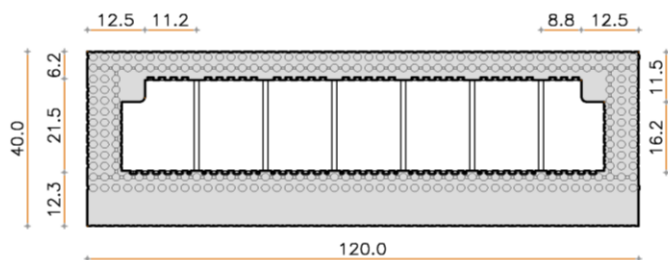

Dimension terminal window element 40/21.5 (120x40x30)

section

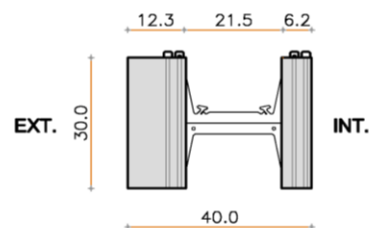

Terminal window element 45/21.5

plan

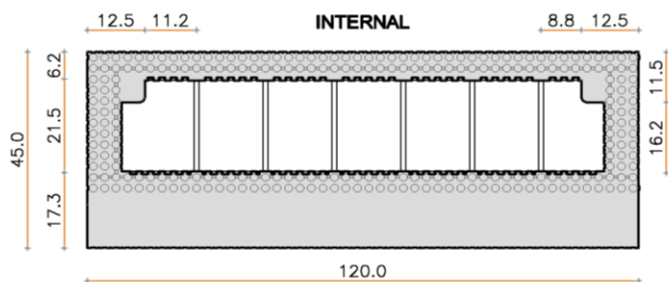

Dimension terminal window element 45/21.5 (120x45x30)

section

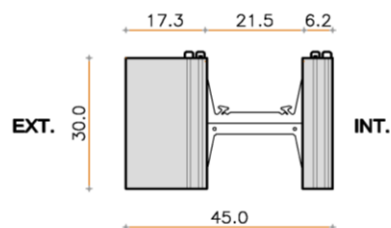

all dimensions in cm

ARGISOL

Special shuttering elements – 21,5 cm
Terminal window elements

Anhang A4.3

Lintel element 35/21.5 plan

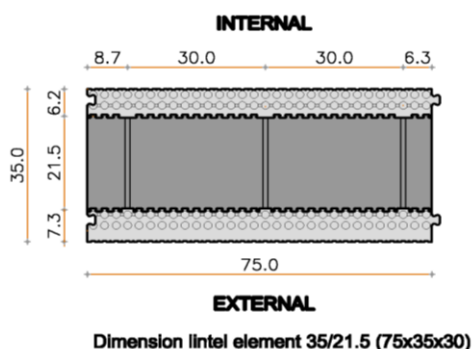

section

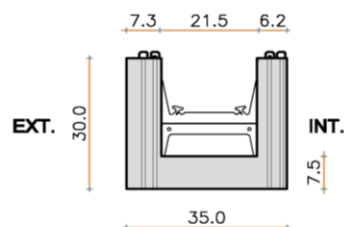

Lintel element 40/21.5 plan

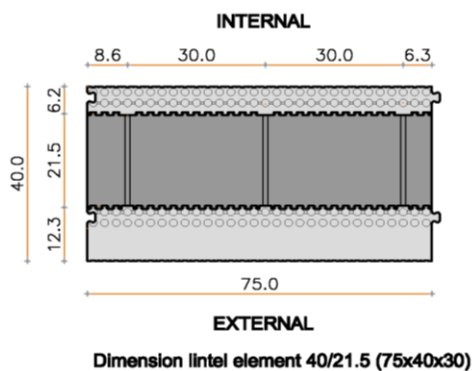

section

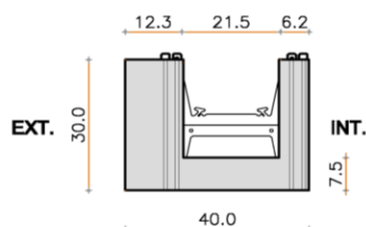

Lintel element 45/21.5 plan

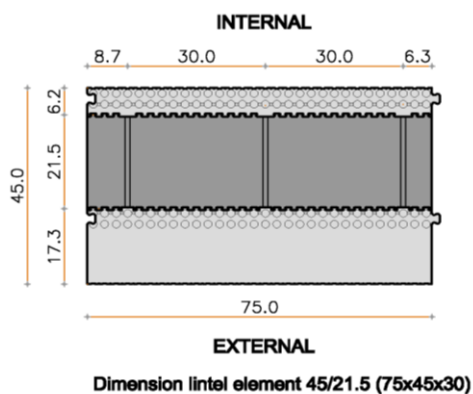

section

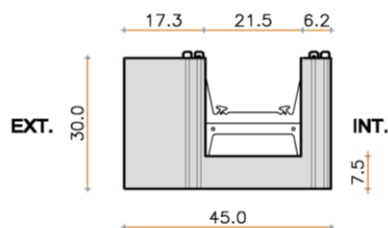

all dimensions in cm

electronic copy of the eta by dibt: eta-07/0105

ARGISOL

Special shuttering elements – 21,5 cm
Lintel elements

Anhang A4.4

Corner shuttering element 35/21.5 plan

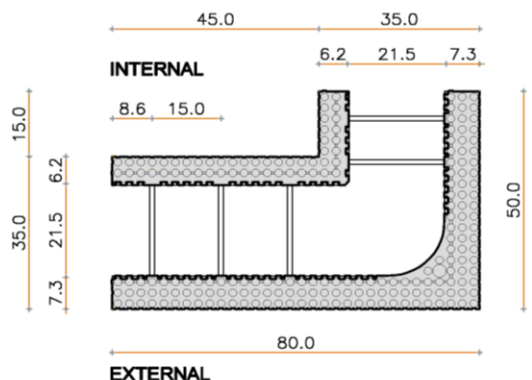

Dimension corner shuttering element 35/21.5 (50-80)x35x30

section

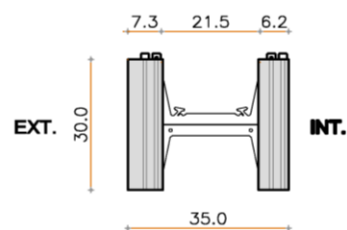

Corner shuttering element 40/21.5 plan

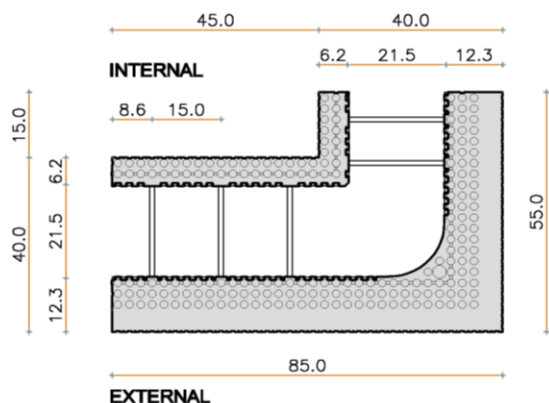

Dimension corner shuttering element 40/21.5 (55-85)x40x30

section

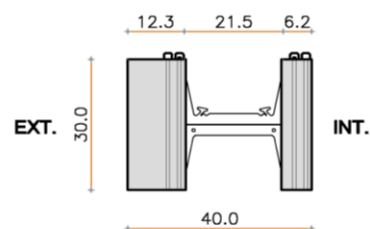

Corner shuttering element 45/21.5

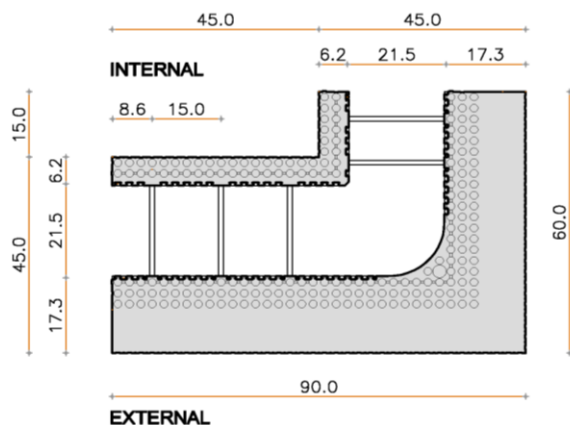

Dimension corner shuttering element 40/21.5 (60-90)x45x30

section

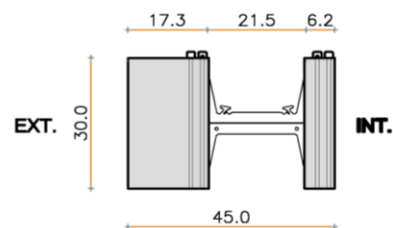

all dimensions in cm

electronic copy of the eta by dibt: eta-07/0105

ARGISOL

Special shuttering elements – 21,5 cm
Corner elements

Anhang A4.5

90° opposite angular shuttering element 40/21.5

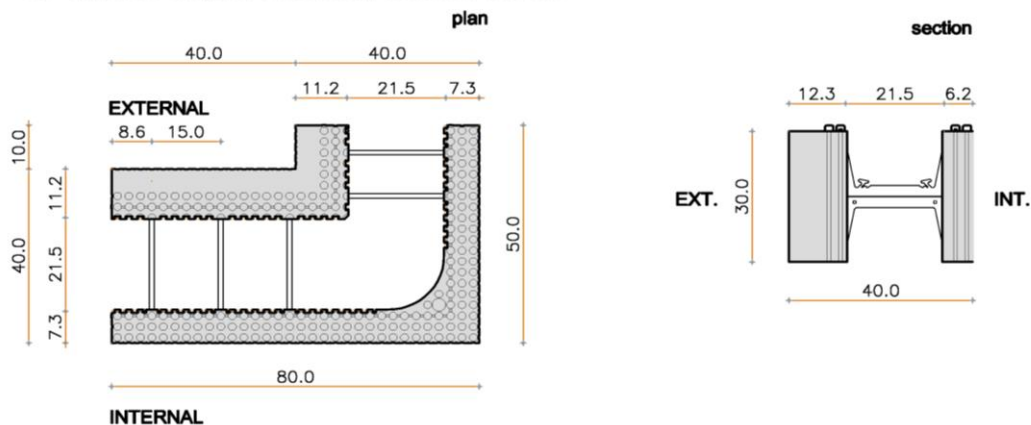

Dimension 90° opposite angular shuttering element 40/21.5 (50-80)x40x30

90° opposite angular shuttering element 45/21.5

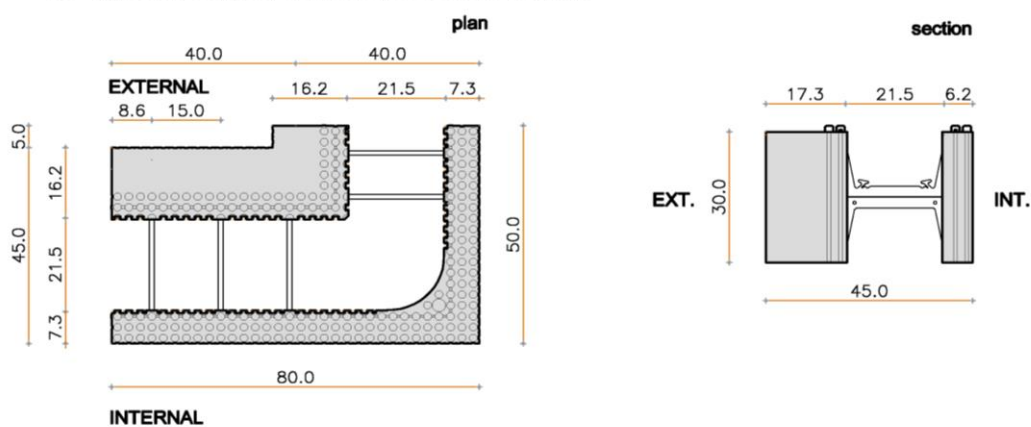

Dimension 90° opposite angular shuttering element 45/21.5 (50-80)x45x30

all dimensions in cm

ARGISOL

Special shuttering elements – 21,5 cm
90° opposite angular elements

Anhang A4.6

Pieces for the equalization of differences in height - l=6.2

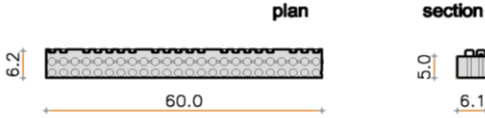

Dimension pieces for the equalization of differences in height - l=6.2 (50x6.2x5)

Pieces for the equalization of differences in height - l=7.3

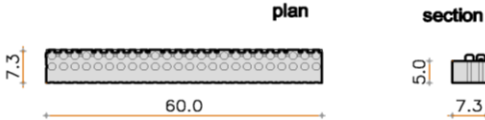

Dimension pieces for the equalization of differences in height - l=7.3 (50x7.3x5)

Pieces for the equalization of differences in height - l=12.3

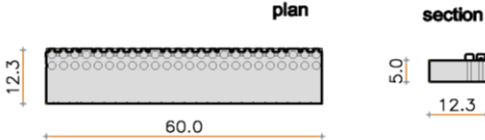

Dimension pieces for the equalization of differences in height - l=12.3 (50x12.3x5)

Pieces for the equalization of differences in height - l=17.3

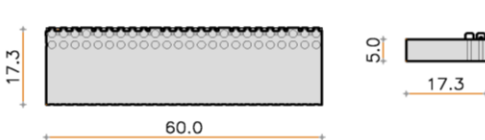

Dimension pieces for the equalization of differences in height - l=17.3 (50x17.3x5)

Single Plates 6.2

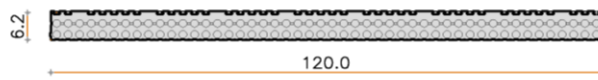

Dimension single plates 6.2 (120x6.2x30)

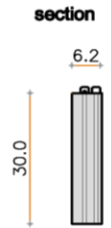

Single Plates 7.3

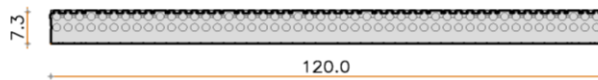

Dimension single plates 7.3 (120x7.3x30)

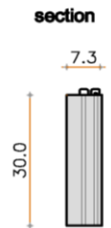

Single Plates 12.3

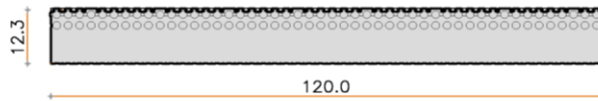

Dimension single plates 12.3 (120x12.3x30)

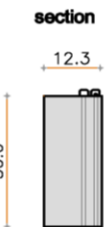

Single Plates 17.3

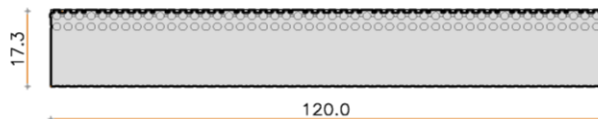

Dimension single plates 17.3 (120x17.3x30)

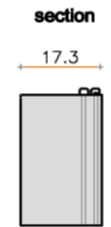

Wood Support Edge

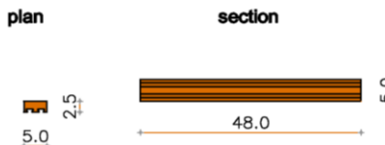

End Stops Wood

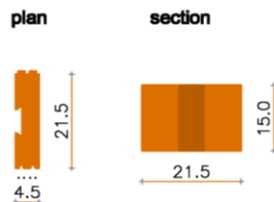

End Stops EPS

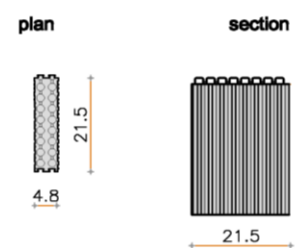

all dimensions in cm

ARGISOL

Accessory parts – 21,5 cm
Pieces for the equalization of differences in height / Single leaves
Wood support edges / End stops (wood or EPS)

Anhang A4.7

Installation

1 General

The manufacturer shall ensure that the requirements in accordance with sections 1 and 3, Annexes A1, B1 and B2 are made known to those involved in planning and execution. The installation guide is deposited with DIBt and shall be present at every construction site. If the manufacturer's instructions contain provisions which differ from those stated here, the specifications of the ETA shall apply.

After installation of the shuttering elements the site-mixed or ready mixed concrete is brought in and compacted.

Under end use conditions walls of the continuous type of unreinforced and reinforced concrete are created.

For structural design purposes the thickness of the wall and the weight per unit area without rendering are shown in Annex B6.

In end use conditions the EPS shuttering leaves are the main part of the thermal insulation of the walls.

The design values of thermal resistance respectively the design values of thermal conductivity shall be laid down according to the relevant national provisions.

2 Installation of the shuttering elements

The shuttering elements are put together on site in layers without mortar or adhesive. To receive stable floor high formworks the vertical joints between two elements of one layer have to be shifted of at least a quarter of the element length, better a half of the element length, to the vertical joints of the previous and next layer (see Annexes B3 and B4).

First of all two layers of the entire floor plan are to be interlocked according to the installation guide of the manufacturer.

Afterwards levelling to the subsoil is performed (foundation, bottom, ground floor and ceiling). Voids between the EPS shuttering leaves and the uneven subsoil are to be sealed with PU foam before concreting.

Subsequently, according to the installation guide of the manufacturer, the shuttering elements are to be interlocked to floor height, levelled and fastened to the push pull props (see Annex B5).

The push pull props shall be arranged with a maximum distance of 0.80 m to be connected over the entire wall height with the shuttering elements and to be fastened to the floor.

The necessary reinforcement according to static calculation shall also be installed according to the instructions in the installation guide provided by the manufacturer.

Rectangular corners are to be formed according to Annex B3. Typical wall junctions are to be formed according to Annex B4.

Further information is given in the installation guide.

3 Concreting

For the production of normal concrete EN 206 shall apply. The consistency of concrete shall be at least within the lower consistency range F3 when compacted by vibration and at least within the upper consistency range F3 when compacted by poking.

The maximum aggregate size shall be at least 8 mm and shall not exceed 16 mm.

Furthermore the concrete shall have rapid or medium strength development according to EN 206, Table 16.

ARGISOL

Installation

Annex B1
Page 1 of 3

Placing the concrete shall be performed only by persons who were instructed in the works and in the proper handling of the shuttering system.

Placing the concrete shall be performed in layers of maximum 0.75 m at a maximum concreting rate of 1 m/h. For curved and angled walls made with shuttering elements the concreting rate shall not exceed 1 m/h.

If equivalent national rules are not available the following instructions shall be considered:

Horizontal cold joints are to be arranged preferably at the height of the floor. If cold joints cannot be avoided within the height between the floors, vertical starter bars shall be installed. The starter bars shall meet the following requirements:

- Two adjacent starter bars shall not be situated in the same plane parallel to the surface of the wall.
- The distance between two starter bars in wall direction shall be at least 10 cm and not larger than 50 cm.
- The total section area of the starter bars shall not be less than 1/2000 of the section area of the concrete.
- Anchorage length of the starter bars on both sides of the cold joint shall be at least 20 cm.

Before the further placing of concrete, cement laitance and detached / loose concrete shall be removed and the cold joints shall be sufficiently pre-wetted. At the time of concreting the surface of the older concrete shall be slightly moist, so that the newly placed concrete can combine well with the older concrete.

If no cold joint is planned, placing of concrete in layers may only be interrupted until the concrete layer placed last has not yet set so that a good and even bond is still possible between the two concrete layers. When using internal vibrators the vibrating cylinder shall still penetrate into the already compacted lower concrete layer.

The concrete may fall freely only up to a height of 2 m, beyond that the concrete shall be cohered by discharge pipes or concreting tubes with a diameter of 100 mm at the most and shall be led shortly before the place of installation.

Cones from placing concrete are to be avoided by short distances of the places of fill in.

Planning shall allow for sufficient spaces in the reinforcement for discharge pipes or concreting tubes.

After concreting the walls may not deviate from the plumb line more than 5 mm per running meter wall height.

The ceiling shall only be placed on walls made of shuttering elements when the concrete core has sufficiently hardened.

4 Ducts crossing and situated inside the wall

Horizontally passing ducts are to be installed according to the installation guide of the ETA holder and are to be taken into account when designing the wall.

Horizontal ducts situated inside the wall cores are to be avoided. If absolutely necessary, these are to be taken into account when designing the wall.

Also vertical ducts in the concrete core shall be considered, if their diameter exceeds 1/6 of the thickness of the concrete core and the distance of the pipes is less than 2 m.

electronic copy of the eta by dibt: eta-07/0105

ARGISOL	Annex B1 Page 2 of 3
Installation	

5 Reworking and finishes

Walls of the type "ARGISOL" are to be protected by finishes (e. g. rendering, plasters, cladding, panelling, coatings). Finishes are not part of the kit and therefore not considered in this ETA. Preferably for external surfaces the rendering systems used should meet the requirement of ETAG 004. The cladding respectively panelling or their substructures shall be anchored in the concrete core. The execution of the rendering shall be performed according to applicable national rules.

The protection by finishes should be implemented preferably within one month after erecting the load-bearing structure, because of the detrimental influence of weather and UV radiation on the surface of the EPS shuttering leaves.

6 Fixing of objects

Fixing of objects in the EPS shuttering leaves is not possible. The part of fixings which is relevant for the mechanical resistance shall be inside the concrete core. The influence of the fixing to the reduction of the declared value of thermal resistance $R_{D,element}$ shall be considered according to EN ISO 6946.

ARGISOL	Annex B1 Page 3 of 3
Installation	

standards and guidelines	issue	title
EN 206	2013 + A1	Concrete – Specification, performance, production and conformity
EN 1992-1-1	2004 + AC:2010 + A1:2014	Eurocode 2: Design of concrete structures – Part 1-1: General rules and rules for buildings;
EN 13163	2012 + A2:2016	Thermal insulation products for buildings – Factory made expanded polystyrene (EPS) products – Specification
EN 13501-1	2007 + A1:2009	Fire classification of construction products and building elements - Part 1: Classification using test data from reaction to fire tests
EN 13501-2	2016	Fire classification of construction products and building elements – Part 2: Classification using data from fire resistance tests, excluding ventilation services;
EN ISO 6946	2017	Building components and building elements - Thermal resistance and thermal transmittance - Calculation method
EN ISO 10456	2007 + AC:2009	Building materials and products - Hygrothermal properties - Tabulated design values and procedures for determining declared and design thermal values
EN ISO 13788	2001	Hygrothermal performance of building components and building elements - Internal surface temperature to avoid critical surface humidity and interstitial condensation - Calculation methods
ETAG 004	2013-06	Guideline for European technical approval of "External thermal insulation composite systems with rendering"
ETAG 009	2002-06	Guideline for European technical approval of "Non load bearing permanent shuttering kits/systems based on hollow blocks or panels of insulating materials and sometimes concrete"
ARGISOL		Annex B2
List of standards and guidelines		

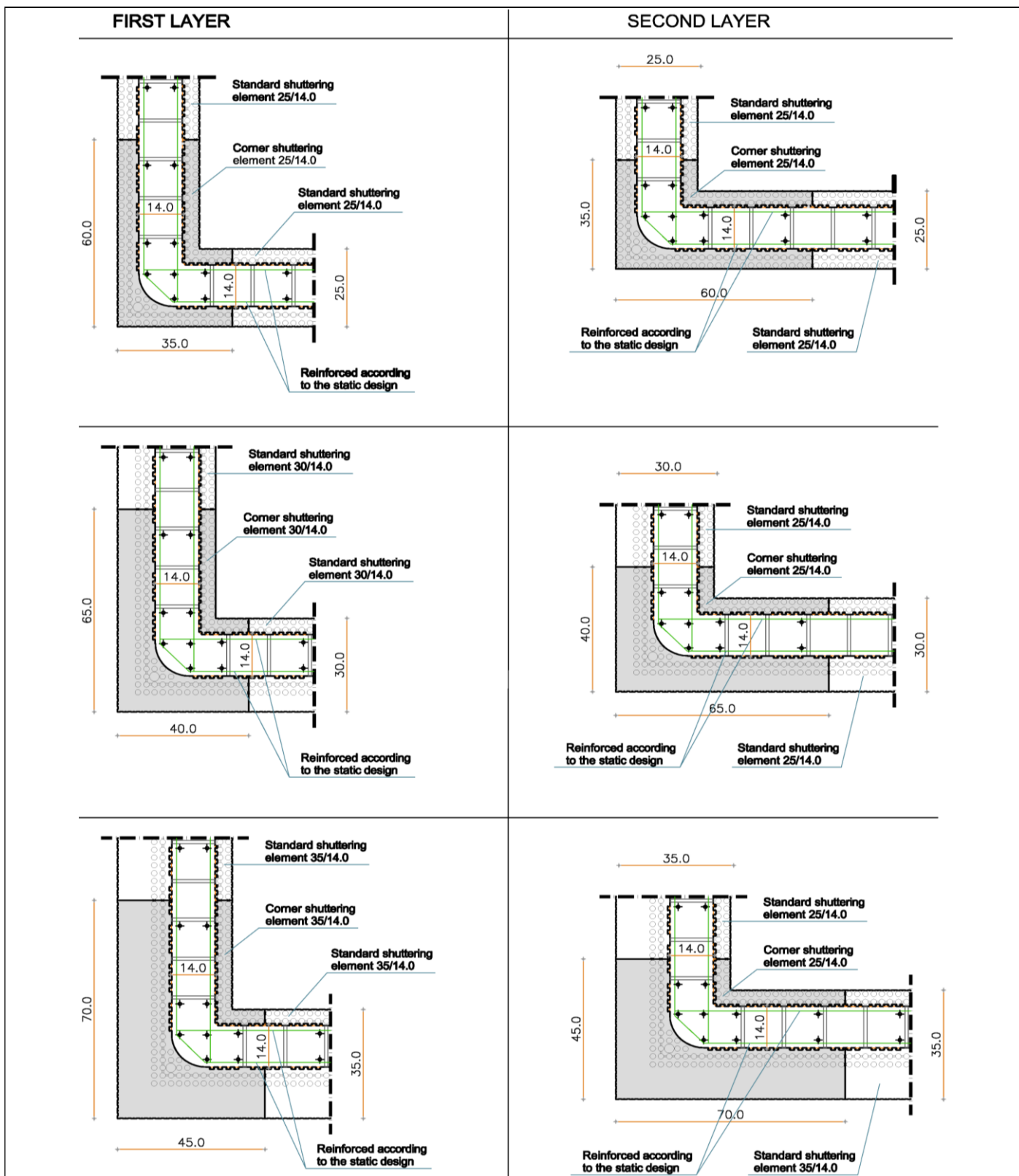

all dimensions in cm

ARGISOL

Bond of different layers – Rectangular wall corners
Concrete core of 14 cm and a thickness of the wall of 25 cm – 30 cm – 35 cm

Annex B3.1

electronic copy of the eta by dibt: eta-07/0105

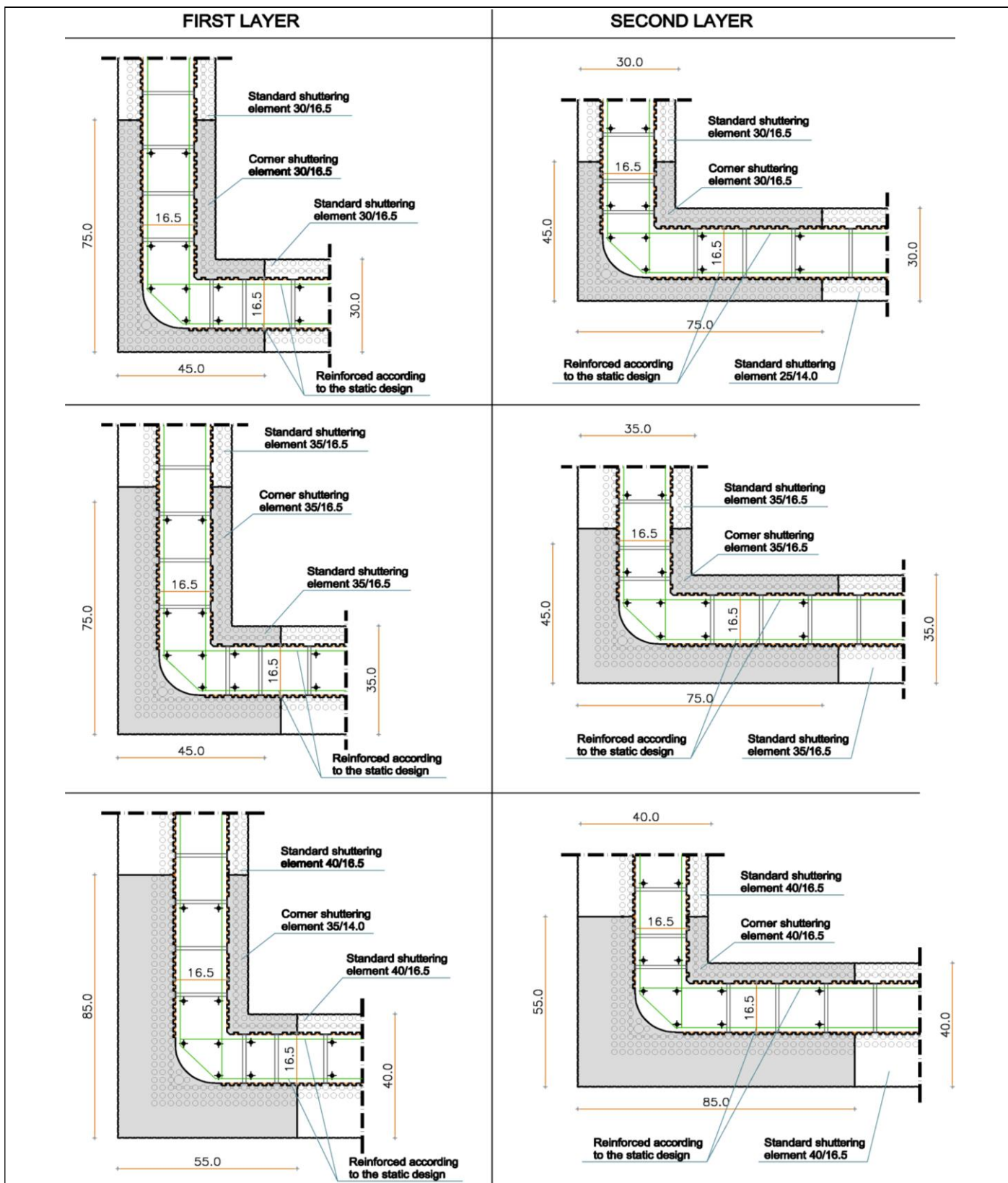

all dimensions in cm

ARGISOL

Bond of different layers – Rectangular wall corners
Concrete core of 16,5 cm and a thickness of the wall of 30 cm – 35 cm – 40 cm

Annex B3.2

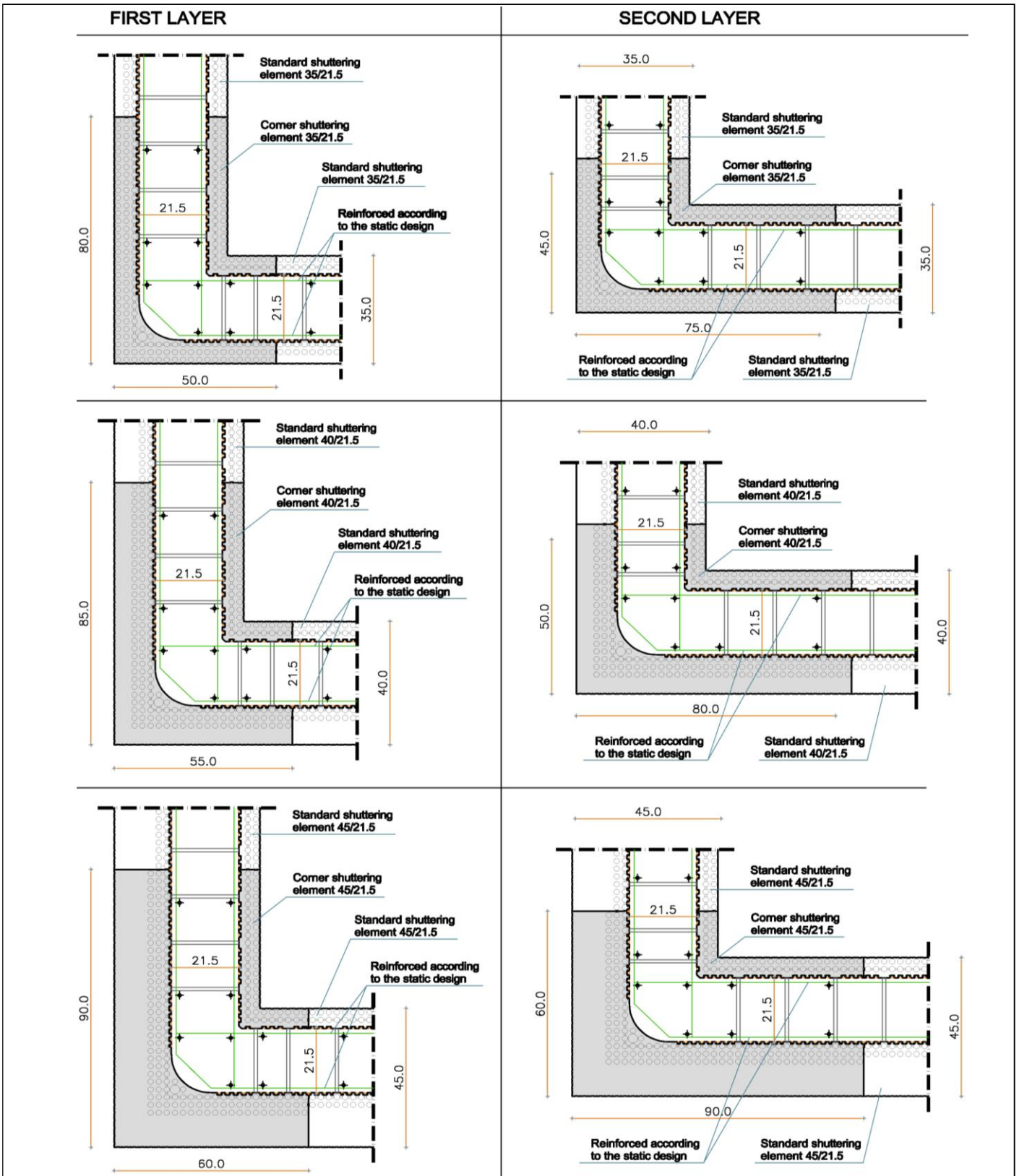

all dimensions in cm

electronic copy of the eta by dibt: eta-07/0105

ARGISOL

Bond of different layers – Rectangular wall corners
Concrete core of 21,5 cm and a thickness of the wall of 35 cm – 40 cm – 45 cm

Annex B3.3

English translation prepared by DIBt

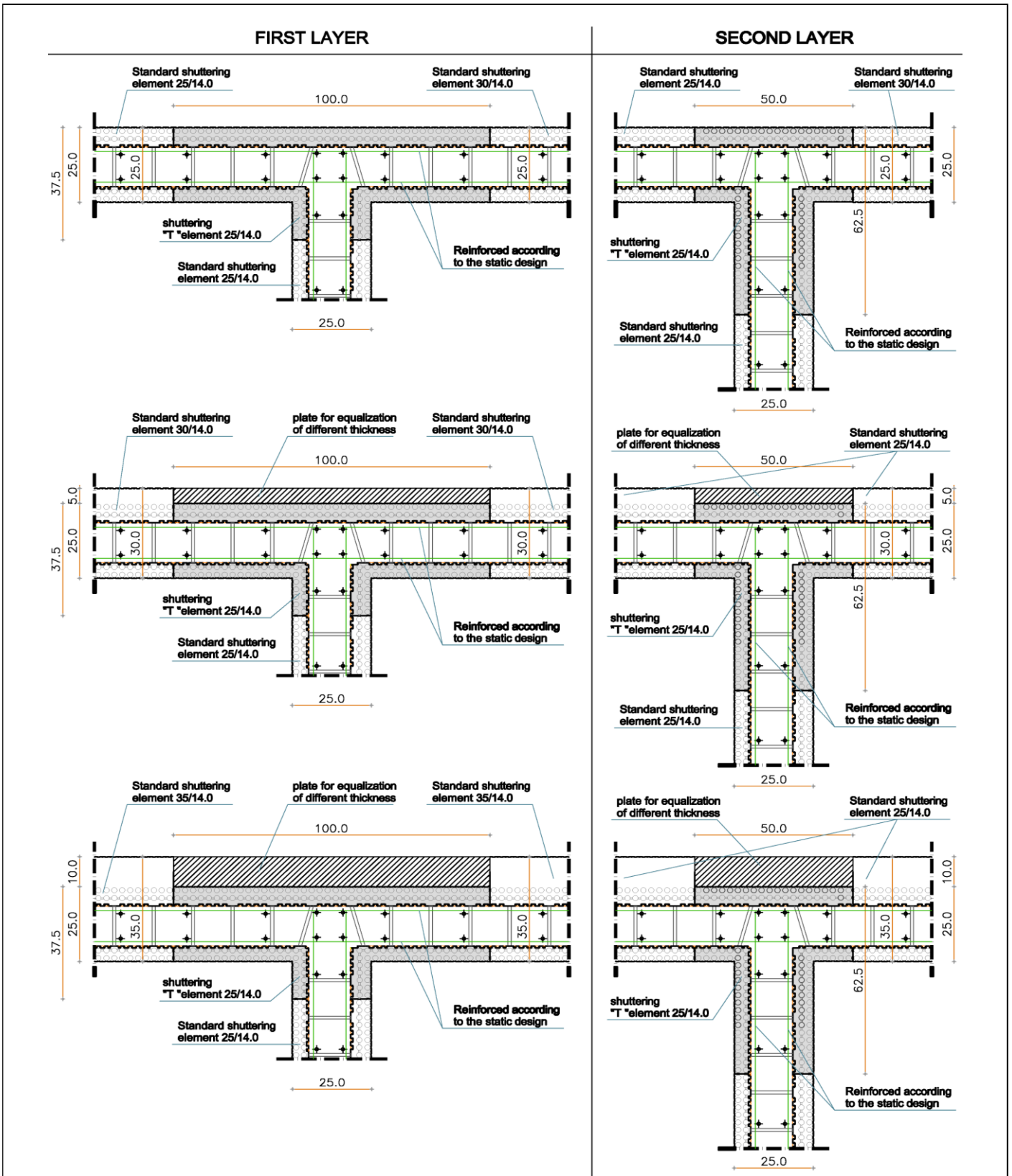

electronic copy of the eta by dibt: eta-07/0105

ARGISOL
Bond of different layers – Wall junctions
Concrete core of 14 cm and a thickness of the wall of 25 cm – 30 cm – 35 cm

Annex B4.1

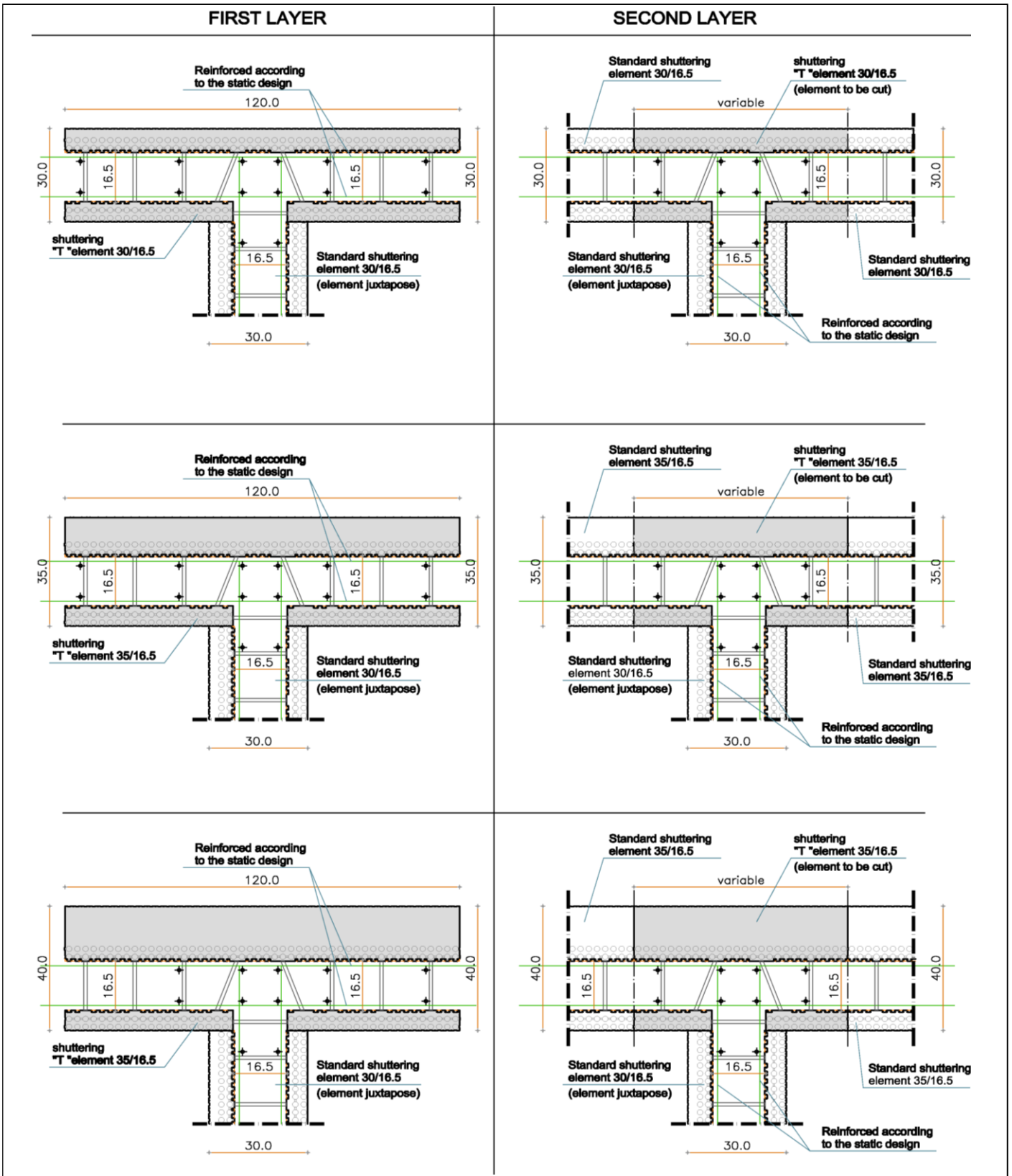

all dimensions in cm

ARGISOL

Bond of different layers – Wall junctions
Concrete core of 16,5 cm and a thickness of the wall of 30 cm – 35 cm – 40 cm

Annex B4.2

English translation prepared by DIBt

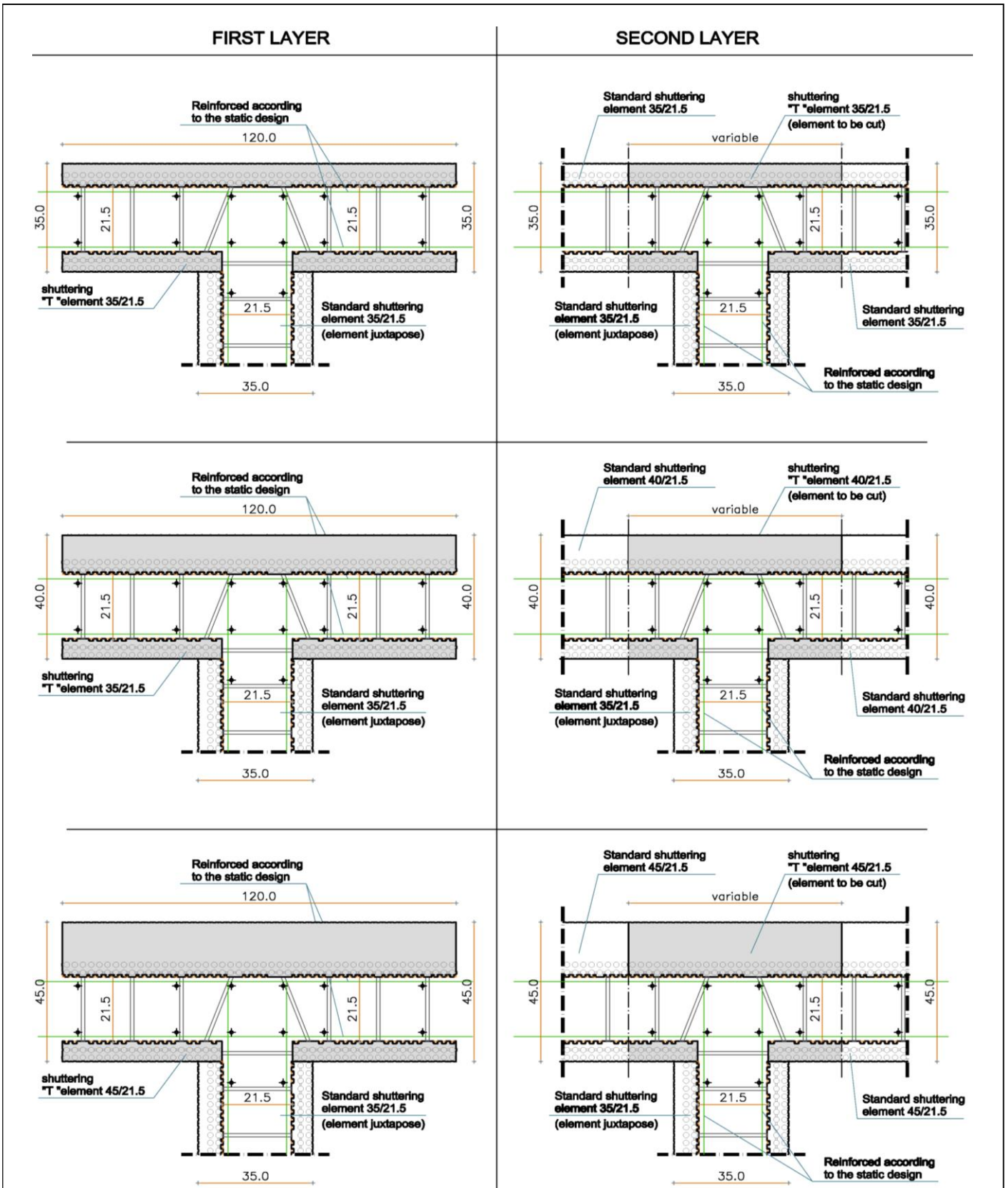

all dimensions in cm

ARGISOL

Bond of different layers – Wall junctions
Concrete core of 21,5 cm and a thickness of the wall of 35 cm – 40 cm – 45 cm

Annex B4.3

electronic copy of the eta by dibt: eta-07/0105

VERTICAL SECTION

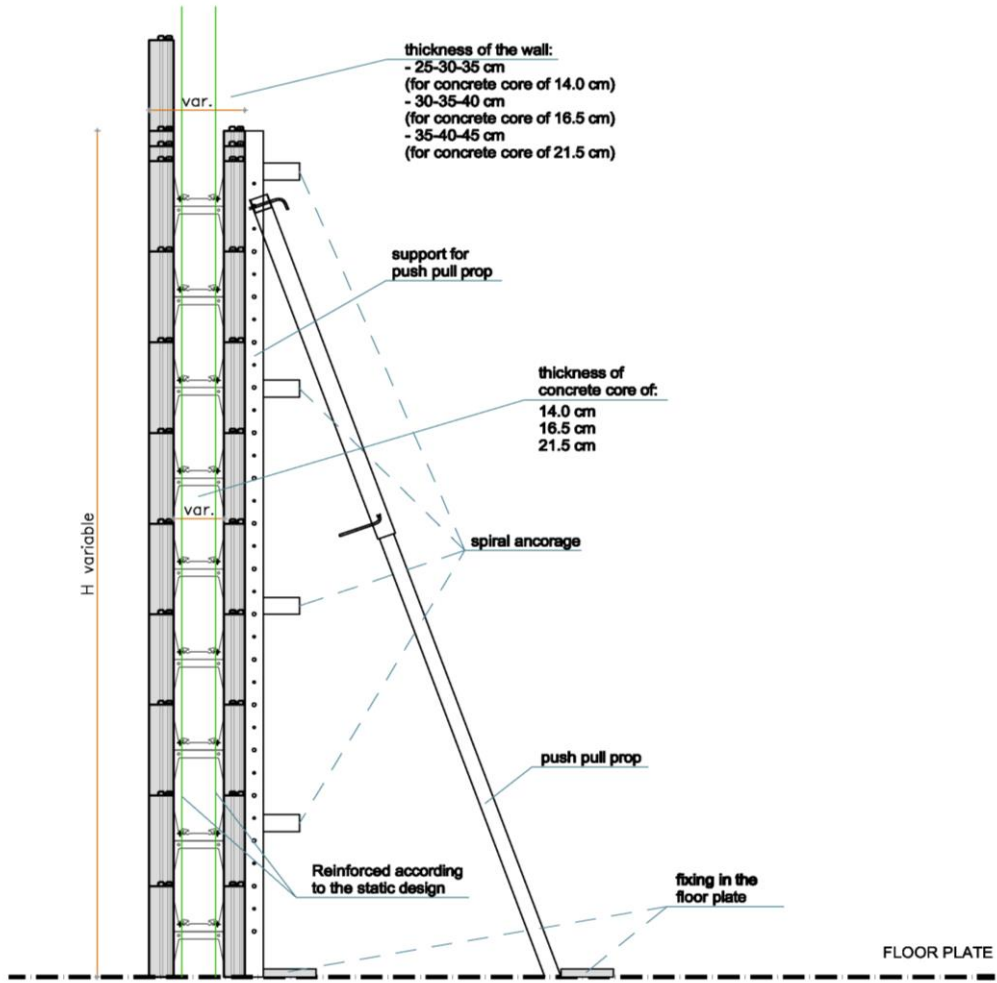

PLAN

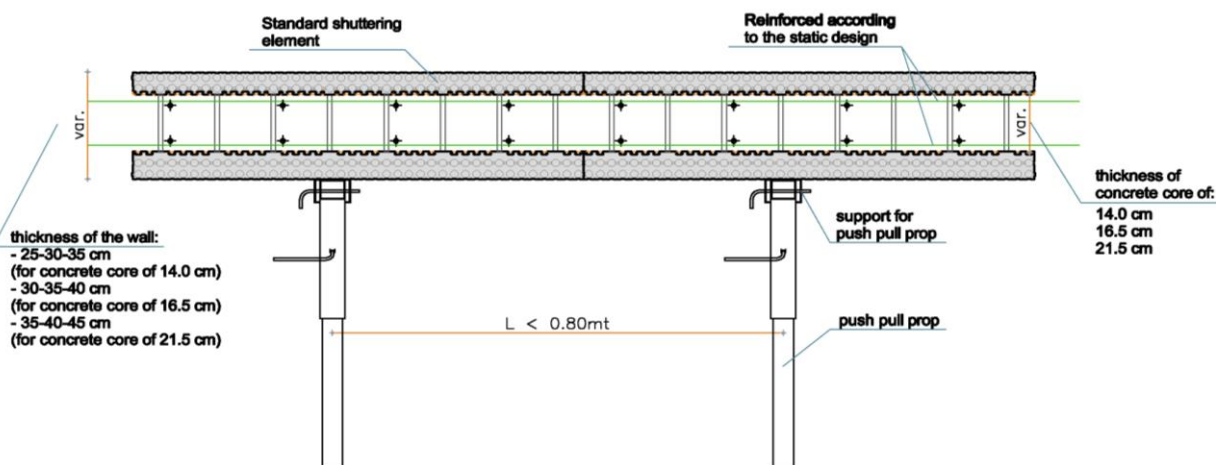

electronic copy of the eta by dibt: eta-07/0105

ARGISOL

Scaffolding when placing concrete

Annex B5

Values of wall elements for combinations of ARGISOL shuttering elements

Type of the wall	Thickness of the wall	Thickness of EPS shuttering leaves		Thickness of concrete core	Nominal value of thermal resistance of shuttering element				concrete core $R_{D,concrete}$ * [(m²xK)/W]	shuttering leaves $R_{D,EPS}$ * [(m²xK)/W]	concrete core $R_{D,concrete}$ * [(m²xK)/W]	Volume of concrete core [m³/m²]	Weight of ARGISOL parts per m² [kN/m²]	Weight of concrete at 24 kN/m³ per m² [kN/m²]
		inner [mm]	outer [mm]		$R_{D,element}$ * [(m²xK)/W]	reduction factor (clause 2.2.7.1) [-]	Including factor $R_{D,element,Factor}$ * [(m²xK)/W]							
Wall/Concrete	[mm]	[mm]	[mm]	[kN/m²]	3,604	0,800	2,884	3,548	0,056	0,140	0,052	3,36	3,36	
25/14.0	250	48	62	140	3,604	0,800	2,884	3,548	0,056	0,140	0,052	3,36	3,36	
30/14.0	300	48	112	140	5,217	0,800	4,174	5,161	0,056	0,140	0,062	3,36	3,36	
35/14.0	350	48	162	140	6,830	0,900	6,147	6,774	0,056	0,140	0,072	3,36	3,36	
30/16.5	300	62	73	165	4,421	0,800	3,537	4,355	0,066	0,165	0,063	3,96	3,96	
35/16.5	350	62	123	165	6,034	0,800	4,827	5,968	0,066	0,165	0,074	3,96	3,96	
40/16.5	400	62	173	165	7,647	0,900	6,882	7,581	0,066	0,165	0,086	3,96	3,96	
35/21.5	300	62	73	165	4,421	0,800	3,537	4,355	0,066	0,215	0,063	5,16	5,16	
40/21.5	350	62	123	165	6,034	0,800	4,827	5,968	0,066	0,215	0,074	5,16	5,16	
45/21.5	400	62	173	165	7,647	0,900	6,882	7,581	0,066	0,215	0,086	5,16	5,16	

Nominal value of thermal conductivity λ [W/mxK]

Type	Shuttering elements	Concrete core
λ [W/mxK]	0,031	2,5

* The nominal value of thermal resistance of the shuttering elements, the shuttering leaves and the concrete core is calculated in accordance with clause 2.2.7.1 with following factors:

ARGISOL

Thicknesses of walls and concrete core
Nominal values of thermal resistance R_D
Geometry, volumes and weights

Annex B6