

Public-law institution jointly founded by the federal states and the Federation

European Technical Assessment Body  
for construction products



## European Technical Assessment

**ETA-18/0878**  
**of 16 October 2024**

English translation prepared by DIBt - Original version in German language

### General Part

Technical Assessment Body issuing the European Technical Assessment:

Deutsches Institut für Bautechnik

Trade name of the construction product

PFEIFER Tension Rod System UMIX

Product family to which the construction product belongs

Prefabricated tension rod system with special end connectors

Manufacturer

PFEIFER Steel Production Poland  
ul. Wroclawska 68  
PL-55330 KREPICE K/WROCLAWIA  
POLEN

Manufacturing plant

T1  
T2

This European Technical Assessment contains

34 pages including 29 annexes which form an integral part of this assessment

This European Technical Assessment is issued in accordance with Regulation (EU) No 305/2011, on the basis of

EAD 200032-00-0602

This version replaces

ETA-18/0878 issued on 22 September 2023

The European Technical Assessment is issued by the Technical Assessment Body in its official language. Translations of this European Technical Assessment in other languages shall fully correspond to the original issued document and shall be identified as such.

Communication of this European Technical Assessment, including transmission by electronic means, shall be in full. However, partial reproduction may only be made with the written consent of the issuing Technical Assessment Body. Any partial reproduction shall be identified as such.

This European Technical Assessment may be withdrawn by the issuing Technical Assessment Body, in particular pursuant to information by the Commission in accordance with Article 25(3) of Regulation (EU) No 305/2011.

## Specific part

### 1 Technical description of the product

The construction product is a prefabricated tension rod system of different system sizes made of steel and stainless steel and is used as a kit (see Annexes A1 and A2). The tension rod system consists of tension rods with external threads which are connected to each other and to the corresponding structure by special connecting devices. The tension rods are connected to the corresponding structure by fork end connectors with two eye loops and internal thread. The fork end connectors are connected by double shear pin connections to corresponding connecting plates or intersection plates. The tension rods can be connected to each other by couplers, connectors, intersection couplers or by a double shear pin with a spade end connection.

The tension rod system comprises tension rods, fork end connectors, pins, connecting plates, intersection plates, couplers, connectors, intersection couplers, spade end connectors and adapters with metric ISO threads M 8 to M 120.

Drawings of the tension rod system and the components as well as the essential dimensions of the components are given in the Annexes to this ETA.

Dimensions and tolerances not indicated in the Annexes shall correspond to the indications laid down in the technical documentation<sup>1</sup> to this European Technical Assessment.

### 2 Specification of the intended use in accordance with the applicable European Assessment Document

The tension rod system is intended for the use in structures with static or quasi-static loads according to EN 1990:2002, where no verification of fatigue relating to EN 1993-1-9:2005 is necessary.

The intended use comprises for instance the suspension of roof structures or vertical glazings as well as bracings and truss structures.

The tension rod system is not subjected to systematic bending.

The fork end connectors may also be connected to compression struts. The compression struts themselves are not part of the ETA.

The performances given in Section 3 are only valid if the tension rod system is used in compliance with the specifications and conditions given the Annexes.

The verifications and assessment methods on which this European Technical Assessment is based lead to the assumption of a working life of the tension rod system of at least 25 years. The indications given on the working life cannot be interpreted as a guarantee given by the producer, but are to be regarded only as a means for choosing the right products in relation to the expected economically reasonable working life of the works.

<sup>1</sup> The technical documentation to this European Technical Assessment is deposited with Deutsches Institut für Bautechnik and, as far as relevant for the tasks of the approved bodies involved in the attestation of conformity procedure is handed over to the approved bodies.

### 3 Performance of the product and references to the methods used for its assessment

#### 3.1 Mechanical resistance and stability (BWR 1)

##### 3.1.1 Fork end connector, pin, connecting plate, intersection plate, coupler, connector, intersection coupler, spade end connector and adapter

Essential characteristic	Performance
Geometry incl. tolerances	See Annexes A3, A4, A6 to A12 and A14 to A18
Dimensions incl. tolerances	
Thread incl. tolerances	
Material	See Annex A19 and A20
Load bearing capacity	See Annex B1, B2 and C1 to C6
Resistance to corrosion	

##### 3.1.2 Tension rod

Essential characteristic	Performance
Nominal rod diameter	See Annexes A5 and A13
Thread incl. tolerances	
Yield strength	See Annex A19 and A20
Tensile strength	
Material	
Tension resistance	See Annex B1, B2 and C1 to C6
Compression force	
Resistance to corrosion	

#### 3.2 Safety in case of fire (BWR 2)

Tension rod, fork end connector, pin, connecting plate, intersection plate, coupler, connector, intersection coupler, spade end connector and adapter

Essential characteristic	Performance
Reaction to fire	Class A1 according to EN 13501-1:2007+A1:2009

The components of the tension rod system satisfy the requirements for performance class A1 of the characteristic reaction to fire, in accordance with the provisions of EC decision 96/603/EC (as amended).

#### 3.3 Safety and accessibility in use (BWR 4)

Same as BWR 1.

**4 Assessment and verification of constancy of performance (AVCP) system applied, with reference to its legal base**

In accordance with European Assessment Document EAD No. 200032-00-0602, the applicable European legal act is: 98/214/EC.

The system to be applied is: 2+

**5 Technical details necessary for the implementation of the AVCP system, as provided for in the applicable EAD**

Technical details necessary for the implementation of the AVCP system are laid down in the control plan deposited with Deutsches Institut für Bautechnik.

Issued in Berlin on 16 October 2024 by Deutsches Institut für Bautechnik

Dr.-Ing. Ronald Schwuchow  
Head of Section

*beglaubigt:*  
Bertram

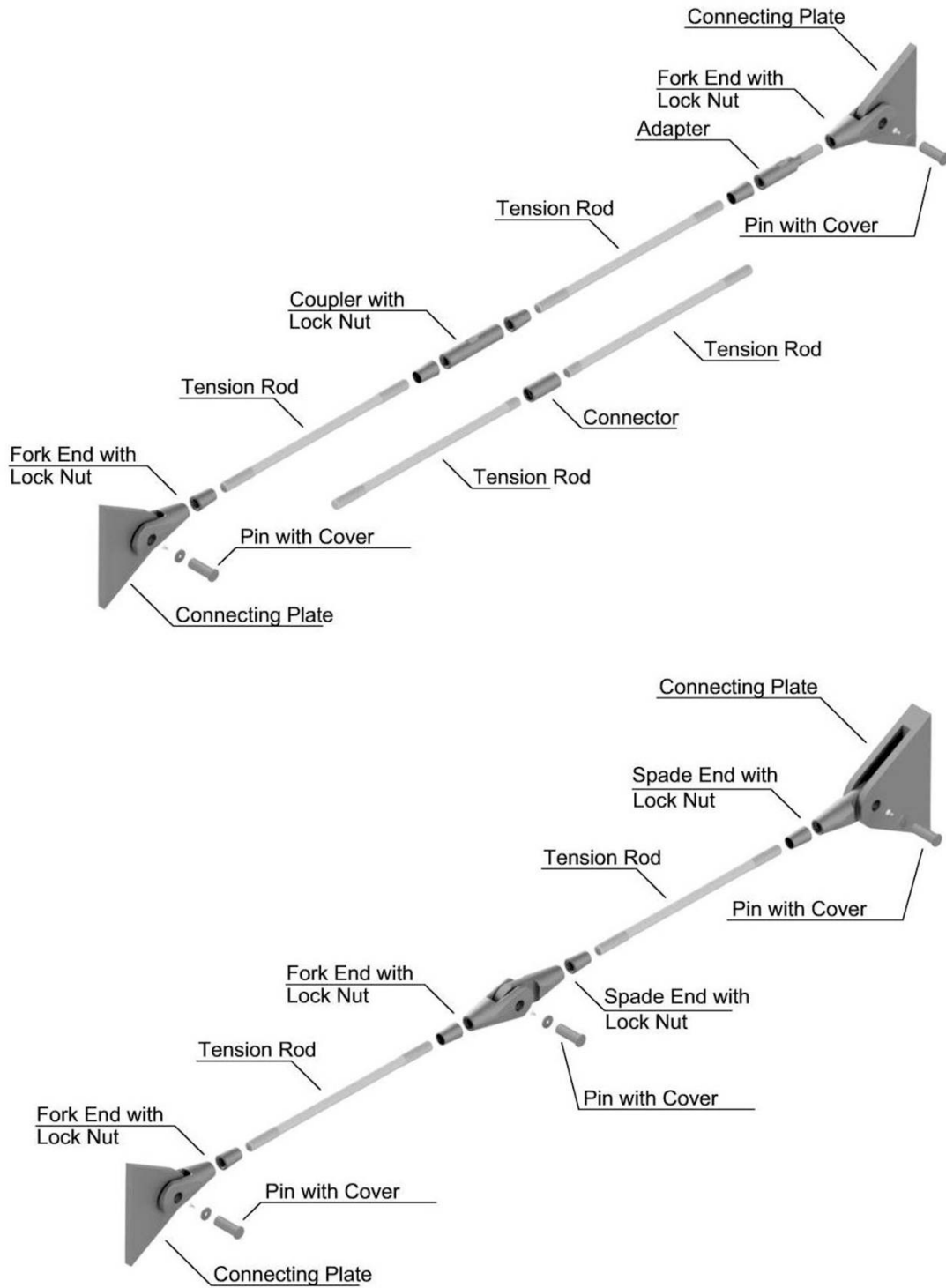

**PFEIFER-Tension Rod System UMIX**

**Product Description**  
Overview, Components

**Annex A1**

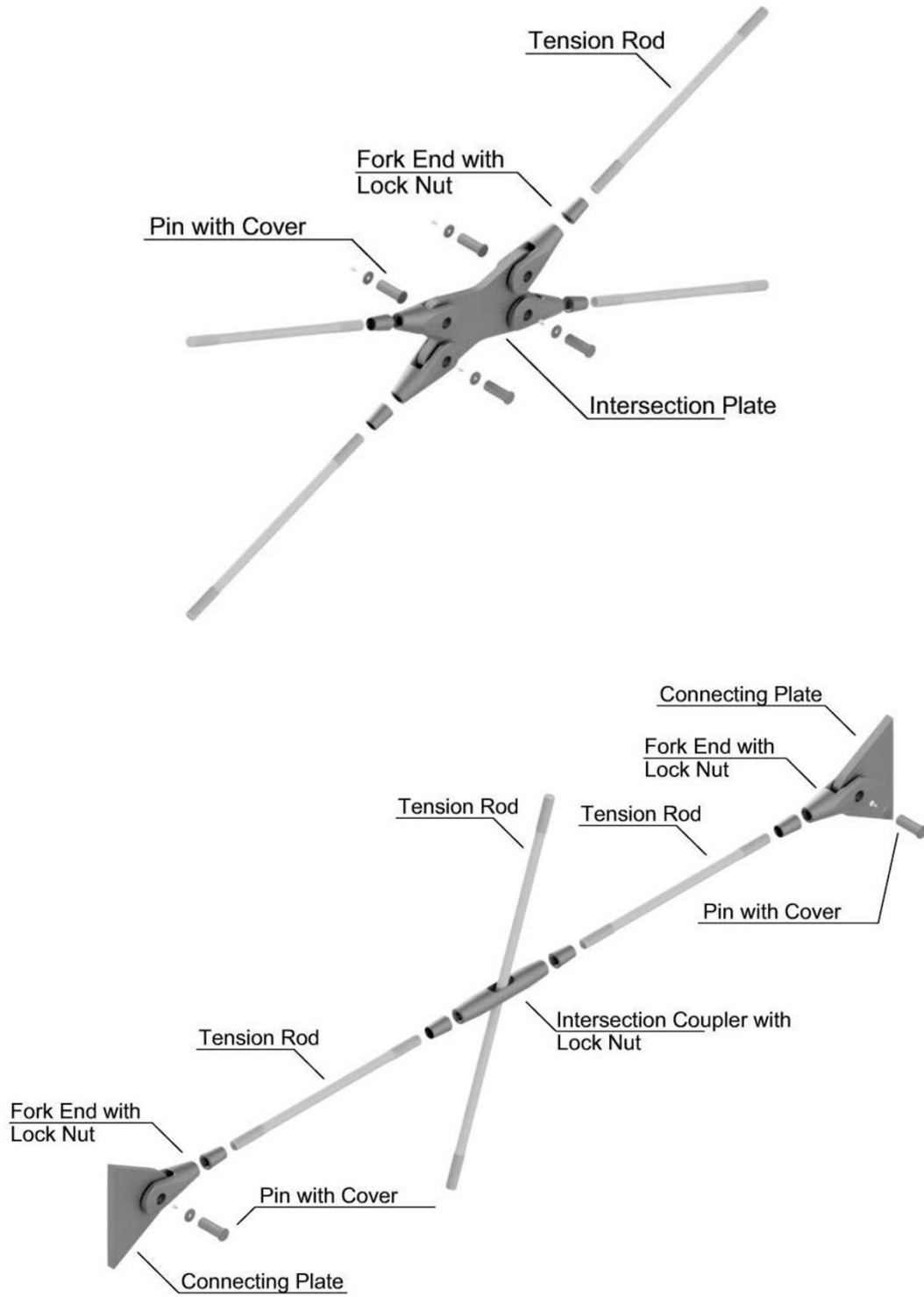

**PFEIFER-Tension Rod System UMIK**

**Product Description**  
Overview, Components

**Annex A2**

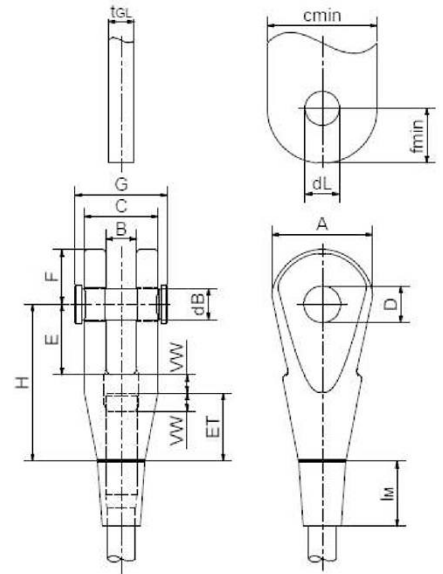

Table A1: **Dimensions Fork End STEEL**

Size M [mm]	Fork End									Pin		Lock Nut	Connecting Plate			
	A [mm]	B [mm]	C [mm]	D [mm]	E [mm]	F [mm]	H [mm]	ET [mm]	±VW [mm]	dB [mm]	G [mm]	l <sub>M</sub> [mm]	t <sub>GL</sub> [mm]	f <sub>min</sub> [mm]	c <sub>min</sub> [mm]	d <sub>L</sub> [mm]
8	26	10	21	9	18,5	14,5	40,5	17,5	4,5	8	29	17	8	14,5	25	9
10	32	12	25,6	11	22,5	17,5	50	22	5,5	10	34,5	21	10	17,5	31	11
12	38,5	14	31	13,5	27,5	21,5	60,5	26	6,5	12	40,5	25	12	21,5	38	13,5
14	47	17	36	16	32	26	73	32	9	14	45,5	31,5	15	26	45	16
16	53	18	40	18	37	29	80	34	9	16	52	33	15	29	53	18
20	66	23	51	22	45	35	100	43,5	11,5	20	65	42	20	35	66	22
24	77	23,5	56,5	26	54	42	120	52	14	24	70,5	50	20	42	78	26
27	87,5	23,5	61,5	30	60	48	134	58	16	27	78	55,5	20	48	88	30
30	98	28,5	70,5	33	65	53	147	64,5	17,5	30	90	62	25	53	98	33
36	115	28,5	79,5	39	76	62	174	77	21	36	99	73	25	62	115	39
42	133	34	94	45	86	72	201	90	25	42	116	86	30	72	135	45
48	151	39	108	51	96	82	227	102,5	28,5	48	130	98	35	82	153	51
52	162	45	121	55	104	88	235	100	31	52	144	105	40	88	163	55
56	176	45	126	59	111	95	252	107,5	33,5	56	149	113	40	95	175	59
60	187	50	138	63	118	100	269	115,5	35,5	60	166	119,5	45	100	186	63
64	200	50	144	67	125	107	286	123,5	37,5	64	172	127	45	107	199	67
70	220	55	157	73	138	117	314	135	41	70	187	138	50	117	217	73
80	257	65	181	83	155	133	356	153,5	47,5	80	215	155	60	133	254	83
90	289	75	210	95	177	152	406	175	55	92	244	175	70	152	288	95
100	325	80	233	109	200	174	453	193	60	106	273	190	75	174	321	109
110	367	91	258	121	222	193	498	211	65	118	300	205	85	193	371	121
120	400	101	283	132	240	210	540	230	70	129	325	220	95	210	394	132

**PFEIFER-Tension Rod System UMIX**

**Product Description**  
Fork End STEEL

**Annex A3**



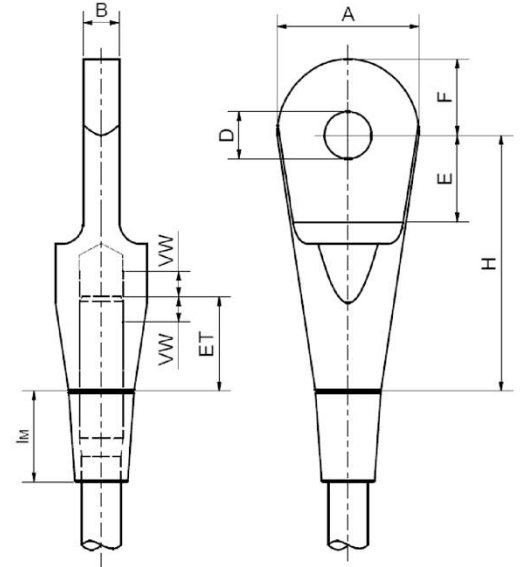

Table A2: **Dimensions Spade End STEEL**

Size	Spade End								Lock Nut
M [mm]	A [mm]	B [mm]	D [mm]	E [mm]	F [mm]	H [mm]	ET [mm]	±VW [mm]	l <sub>m</sub> [mm]
8	25	8	9	16,5	14,5	47,5	17,5	4,5	17
10	31	10	11	20,5	17,5	59	22	5,5	21
12	38	12	13,5	24,5	21,5	70,5	26	6,5	25
14	45	15	16	29	26	86	32	9	31,5
16	53	15	18	33	29	93	34	9	33
20	66	20	22	40	35	117	43,5	11,5	42
24	78	20	26	48	42	141	52	14	50
27	88	20	30	54	48	159	58	16	55,5
30	98	25	33	59	53	173	64,5	17,5	62
36	115	25	39	66	62	205	77	21	73
42	135	30	45	78	72	240	90	25	86
48	153	35	51	87	82	270	102,5	28,5	98
52	163	40	55	94	88	283	100	31	105
56	175	40	59	100	95	305	107,5	33,5	113
60	186	45	63	106	100	320	115,5	35,5	119,5
64	199	45	67	112	107	343	123,5	37,5	127
70	217	50	73	124	117	375	135	41	138
80	254	60	83	139	133	422	153,5	47,5	155
90	288	70	95	158,5	152	481,5	175	55	175
100	321	75	109	180	174	539	193	60	190
110	371	85	121	200	193	584	211	65	205
120	394	95	132	216	210	640	230	70	220

**PFEIFER-Tension Rod System UMIX**

**Product Description**  
Spade End STEEL

**Annex A4**

**Note:**

According to Annex A19 the Tension Rods are available in **different material grades**.  
Observe **the marking** of the Tension Rods due to the **different load capacities!**

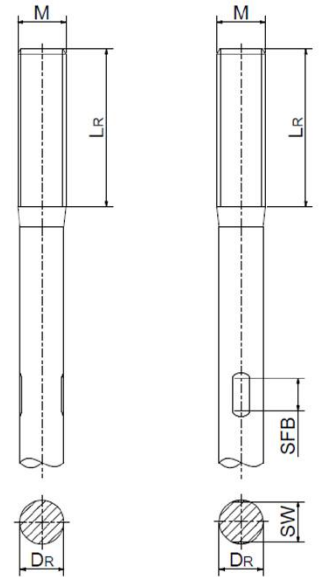
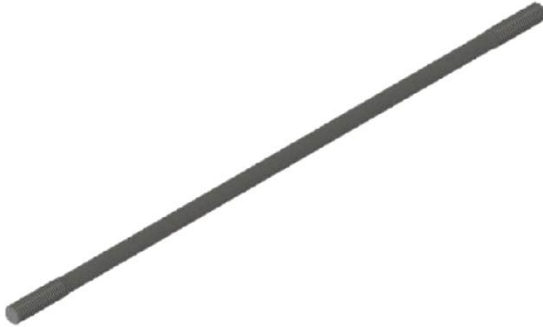

Table A3: **Dimensions Tension Rod STEEL**

Size M [mm]	Tension Rod			
	D <sub>R</sub> [mm]	L <sub>R</sub> [mm]	SFB [mm]	SW [mm]
8	7	26	12	6,3
10	9	32,5	12	8
12	10,5	38,5	12	9,5
14	12,5	48	12	11
16	14,5	51	16	13
20	18	65	16	16,5
24	22	78	16	20
27	25	87,5	16	23
30	28	97	20	25
36	33	116	20	30
42	39	136	20	36
48	45	155	20	41
52	49	157	---	---
56	52	169	---	---
60	56	181	---	---
64	60	193	---	---
70	66	212	---	---
80	76	241	---	---
90	86	275	---	---
100	96	303	---	---
110	106	331	---	---
120	116	360	---	---

**PFEIFER-Tension Rod System UMIK**

**Product Description**  
Tension Rod *STEEL*

**Annex A5**

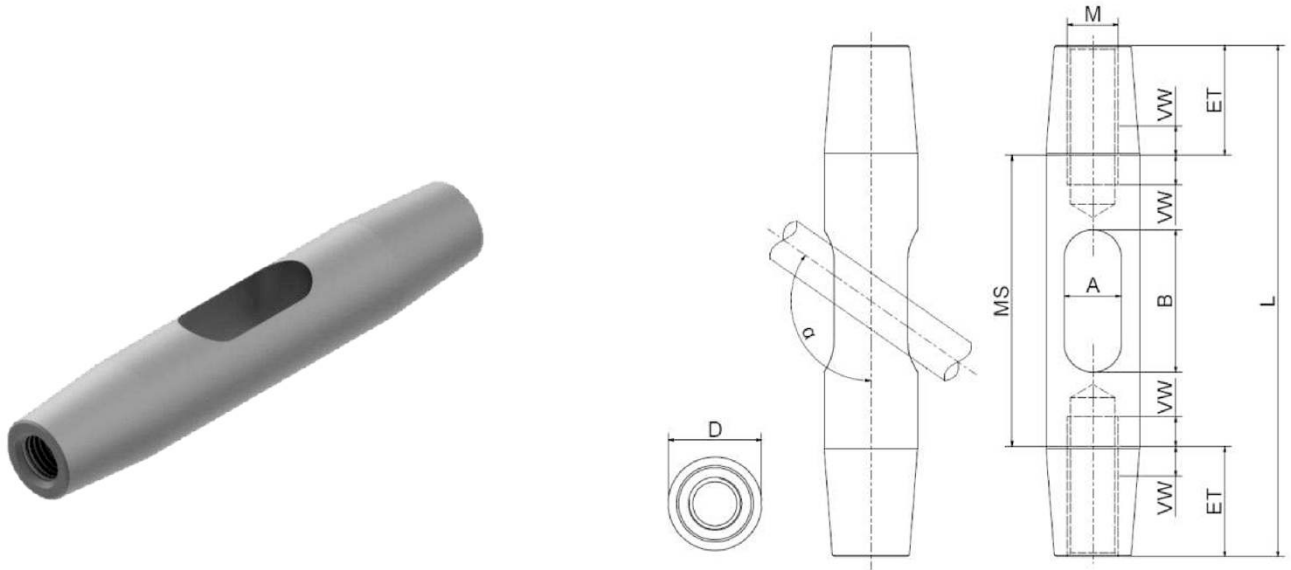

Table A4: **Dimensions Intersection Coupler STEEL**

Size	Intersection Coupler							
	M [mm]	L [mm]	D [mm]	MS [mm]	A [mm]	B [mm]	$\alpha$ [°]	ET [mm]
8	86	16	51	10,5	26	125	17,5	4,5
10	106	20	62	13	31	125	22	5,5
12	126	23	74	15	36	125	26	6,5
14	149	27	85	17	41	125	32	9
16	162	30	94	19	48	125	34	9
20	203	37	116	23	57	125	43,5	11,5
24	241	44	137	27	67	125	52	14
27	271	49	155	30	78	125	58	16
30	300	55	171	34	84	125	64,5	17,5
36	332	65	178	40	100	125	77	21
42	389	76	209	46	117	125	90	25
48	443	86	238	52	133	125	102,5	28,5
52	460	94	260	57	146	125	100	31
56	497	101	282	61	159	125	107,5	33,5
60	534	108	303	65	172	125	115,5	35,5
64	563	115	316	69	177	125	123,5	37,5
70	614	126	344	76	192	125	135	41
80	704	144	397	86	222	125	153,5	47,5
90	800	162	450	96	250	125	175	55
100	884	180	498	106	278	125	193	60
110	968	198	546	116	306	125	211	65
120	1055	216	595	126	335	125	230	70

**PFEIFER-Tension Rod System UMIX**

**Product Description**  
Intersection Coupler *STEEL*

**Annex A6**

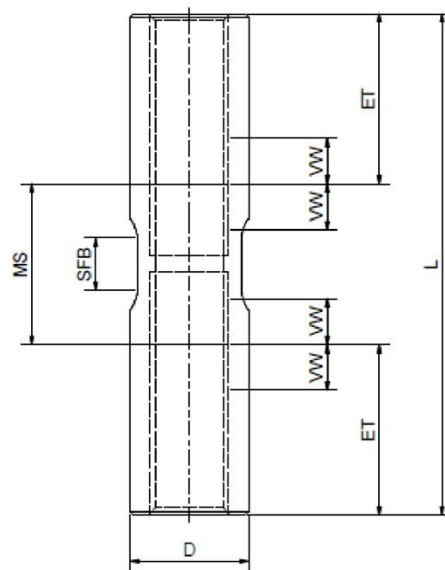
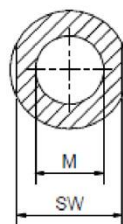

Table A5: **Dimensions Coupler STEEL**

Size	Coupler						
M [mm]	L [mm]	D [mm]	MS [mm]	SFB [mm]	SW [mm]	ET [mm]	±VW [mm]
8	56	12	21	12	11	17,5	4,5
10	68	15	24	12	13	22	5,5
12	80	18	28	12	16	26	6,5
14	92	21	28	12	19	32	9
16	104	24	36	16	22	34	9
20	129	30	42	16	27	43,5	11,5
24	153	36	49	16	32	52	14
27	171	40,5	55	16	36	58	16
30	196	45	67	20	40	64,5	17,5
36	232	54	78	20	49	77	21
42	269	63	89	20	57	90	25
48	306	72	101	20	65	102,5	28,5
52	266	78	66	---	---	100	31
56	288	84	73	---	---	107,5	33,5
60	308	90	77	---	---	115,5	35,5
64	327	96	80	---	---	123,5	37,5
70	358	105	88	---	---	135	41
80	408	120	101	---	---	153,5	47,5
90	466	135	116	---	---	175	55
100	512	150	126	---	---	193	60
110	558	165	136	---	---	211	65
120	606	180	146	---	---	230	70

**PFEIFER-Tension Rod System UMIK**

**Product Description**  
Coupler *STEEL*

**Annex A7**

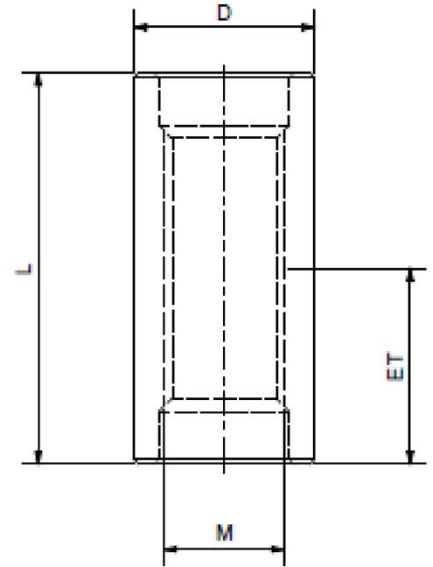

Table A6: **Dimensions Connector STEEL**

Size M [mm]	Connector		
	D [mm]	L [mm]	ET [mm]
8	12	28	14
10	15	35	17,5
12	18	41	20,5
14	21	47	23,5
16	24	52	26
20	30	66	33
24	36	78	39
27	40,5	85	42,5
30	42	97	48,5
36	50	114	57
42	59	132	66
48	67	150	75
52	73	159	79,5
56	79	173	86,5
60	84	183	91,5
64	89	195	97,5
70	98	210	105
80	116	234	117
90	130	258	129
100	145	282	141
110	160	306	153
120	174	330	165

**PFEIFER-Tension Rod System UMIX**

**Product Description**  
Connector *STEEL*

**Annex A8**



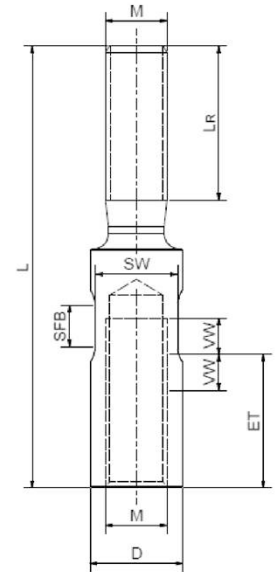

Table A7: **Dimensions Adapter STEEL**

Size M [mm]	Adapter						
	L [mm]	D [mm]	L <sub>R</sub> [mm]	SFB [mm]	SW [mm]	ET [mm]	±VW [mm]
8	60	12	20	12	11	17,5	4,5
10	74	15	25	12	13	22	5,5
12	89	18	30	12	16	26	6,5
14	107	21	37	12	19	32	9
16	113,5	24	39	16	22	34	9
20	144	30	50	16	27	43,5	11,5
24	172	36	60	16	32	52	14
27	191	40,5	68	16	36	58	16
30	214	45	75	20	40	64,5	17,5
36	242	54	90	20	49	77	21
42	283	63	106	20	57	90	25
48	322	72	121	20	65	102,5	28,5
52	336	78	131	---	---	100	31
56	362	84	141	---	---	107,5	33,5
60	380	90	151	---	---	115,5	35,5
64	412	96	161	---	---	123,5	37,5
70	459	105	176	---	---	135	41
80	520	120	201	---	---	153,5	47,5
90	586	135	230	---	---	175	55
100	643	150	253	---	---	193	60
110	691	165	276	---	---	211	65
120	750	180	300	---	---	230	70

**PFEIFER-Tension Rod System UMIX**

**Product Description**  
Adapter *STEEL*

**Annex A9**

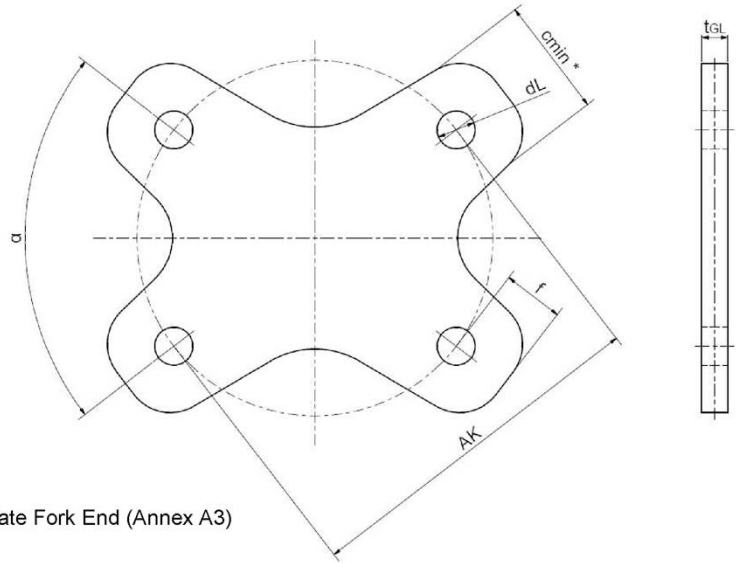
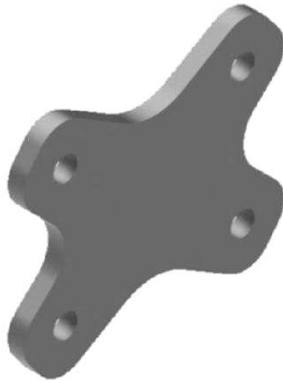

$c_{min}^* \geq c_{min}$  Connecting Plate Fork End (Annex A3)

Table A8: **Dimensions Intersection Plate STEEL**

Size M [mm]	Intersection Plate				
	$t_{GL}$ [mm]	$dL$ [mm]	$f$ [mm]	AK [mm]	$\alpha$ [°]
8	8	9	14,5	83	40-90
10	10	11	17,5	103	40-90
12	12	13,5	21,5	125	40-90
14	15	16	26	148	40-90
16	15	18	29	165	40-90
20	20	22	35	205	40-90
24	20	26	42	245	40-90
27	20	30	48	270	40-90
30	25	33	53	309	40-90
36	25	39	65	356	40-90
42	30	45	72	410	40-90
48	35	51	82	475	40-90
52	40	55	88	509	40-90
56	40	59	95	551	40-90
60	45	63	100	585	40-90
64	45	67	107	626	40-90
70	50	73	117	683	40-90
80	60	83	133	784	40-90
90	70	95	152	885	40-90
100	75	109	174	971	40-90
110	85	121	193	1080	40-90
120	95	132	210	1180	40-90

**PFEIFER-Tension Rod System UMIK**

**Product Description**  
Intersection Plate *STEEL*

**Annex A10**

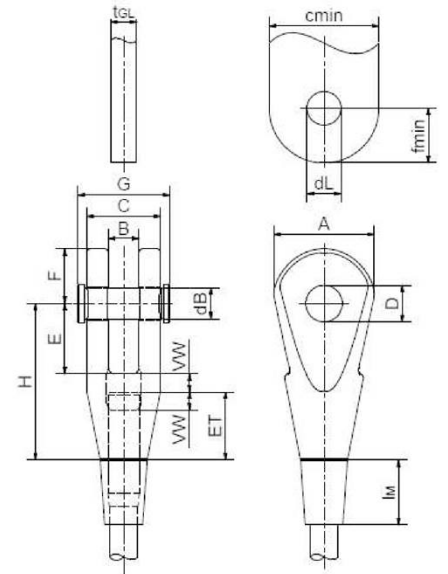

Table A9: **Dimensions Fork End STAINLESS STEEL**

Size M [mm]	Fork End									Pin		Lock Nut	Connecting Plate			
	A [mm]	B [mm]	C [mm]	D [mm]	E [mm]	F [mm]	H [mm]	ET [mm]	±VW [mm]	dB [mm]	G [mm]	l <sub>M</sub> [mm]	t <sub>GL</sub> [mm]	fmin [mm]	cmin [mm]	dL [mm]
8	26	10	21	9	18,5	14,5	40,5	17,5	4,5	8	29	17	8	14,5	25	9
10	32	12	25,6	11	22,5	17,5	50	22	5,5	10	34,5	21	10	17,5	31	11
12	38,5	14	31	13,5	27,5	21,5	60,5	26	6,5	12	40,5	25	12	21,5	38	13,5
14	47	17	36	16	32	26	73	32	9	14	45,5	31,5	15	26	45	16
16	53	18	40	18	37	29	80	34	9	16	52	33	15	29	53	18
20	66	23	51	22	45	35	100	43,5	11,5	20	65	42	20	35	66	22
24	77	23,5	56,5	26	54	42	120	52	14	24	70,5	50	20	42	78	26
27	87,5	23,5	61,5	30	60	48	134	58	16	27	78	55,5	20	48	88	30
30	98	28,5	70,5	33	65	53	147	64,5	17,5	30	90	62	25	53	98	33
36	115	28,5	79,5	39	76	62	174	77	21	36	99	73	25	62	115	39
42	133	34	94	45	86	72	201	90	25	42	116	86	30	72	135	45
48	151	39	108	51	96	82	227	102,5	28,5	48	130	98	35	82	153	51
52	162	45	121	55	104	88	235	100	31	52	144	105	40	88	163	55
56	176	45	126	59	111	95	252	107,5	33,5	56	149	113	40	95	175	59
60	187	50	138	63	118	100	269	115,5	35,5	60	166	119,5	45	100	186	63
64	200	50	144	67	125	107	286	123,5	37,5	64	172	127	45	107	199	67
70	220	55	157	73	138	117	314	135	41	70	187	138	50	117	217	73
80	257	65	181	83	155	133	356	153,5	47,5	80	215	155	60	133	254	83
90	289	75	210	95	177	152	406	175	55	92	244	175	70	152	288	95
100	325	80	233	109	200	174	453	193	60	106	273	190	75	174	321	109
110	367	91	258	121	222	193	498	211	65	118	300	205	85	193	371	121
120	400	101	283	132	240	210	540	230	70	129	325	220	95	210	394	132

**PFEIFER-Tension Rod System UMIX**

**Product Description**  
Fork End *STAINLESS STEEL*

**Annex A11**



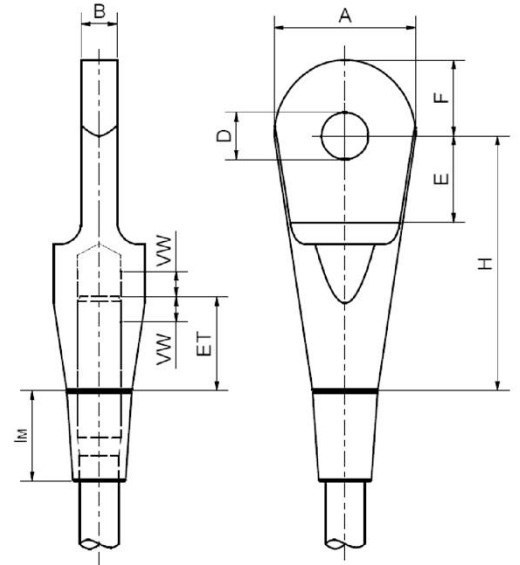

Table A10: **Dimensions Spade End STAINLESS STEEL**

Size	Spade End								Lock Nut
M [mm]	A [mm]	B [mm]	D [mm]	E [mm]	F [mm]	H [mm]	ET [mm]	±VW [mm]	l <sub>M</sub> [mm]
8	25	8	9	16,5	14,5	47,5	17,5	4,5	17
10	31	10	11	20,5	17,5	59	22	5,5	21
12	38	12	13,5	24,5	21,5	70,5	26	6,5	25
14	45	15	16	29	26	86	32	9	31,5
16	53	15	18	33	29	93	34	9	33
20	66	20	22	40	35	117	43,5	11,5	42
24	78	20	26	48	42	141	52	14	50
27	88	20	30	54	48	159	58	16	55,5
30	98	25	33	59	53	173	64,5	17,5	62
36	115	25	39	66	62	205	77	21	73
42	135	30	45	78	72	240	90	25	86
48	153	35	51	87	82	270	102,5	28,5	98
52	163	40	55	94	88	283	100	31	105
56	175	40	59	100	95	305	107,5	33,5	113
60	186	45	63	106	100	320	115,5	35,5	119,5
64	199	45	67	112	107	343	123,5	37,5	127
70	217	50	73	124	117	375	135	41	138
80	254	60	83	139	133	422	153,5	47,5	155
90	288	70	95	158,5	152	481,5	175	55	175
100	321	75	109	180	174	539	193	60	190
110	371	85	121	200	193	584	211	65	205
120	394	95	132	216	210	640	230	70	220

**PFEIFER-Tension Rod System UMIX**

**Product Description**  
Spade End *STAINLESS STEEL*

**Annex A12**

Note:

According to Annex A20 the Tension Rods are available in **different material grades**.  
Observe **the marking** of the Tension Rods due to the **different load capacities!**

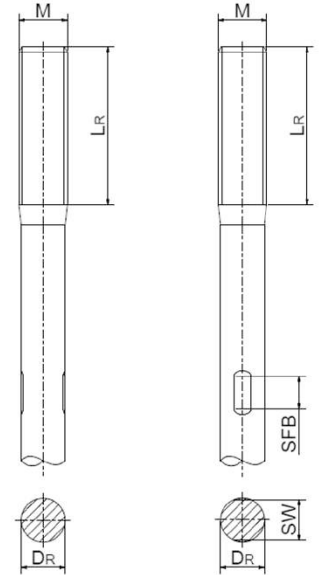
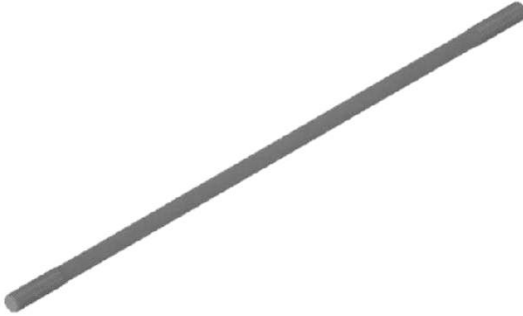

Table A11: **Dimensions Tension Rod STAINLESS STEEL**

Size M [mm]	Tension Rod			
	D <sub>R</sub> [mm]	L <sub>R</sub> [mm]	SFB [mm]	SW [mm]
8	7	26	12	6,3
10	9	32,5	12	8
12	10,5	38,5	12	9,5
14	12,5	48	12	11
16	14,5	51	16	13
20	18	65	16	16,5
24	22	78	16	20
27	25	87,5	16	23
30	28	97	20	25
36	33	116	20	30
42	39	136	20	36
48	45	155	20	41
52	49	157	---	---
56	52	169	---	---
60	56	181	---	---
64	60	193	---	---
70	66	212	---	---
80	76	241	---	---
90	86	275	---	---
100	96	303	---	---
110	106	331	---	---
120	116	360	---	---

**PFEIFER-Tension Rod System UMIK**

**Product Description**  
Tension Rod *STAINLESS STEEL*

**Annex A13**

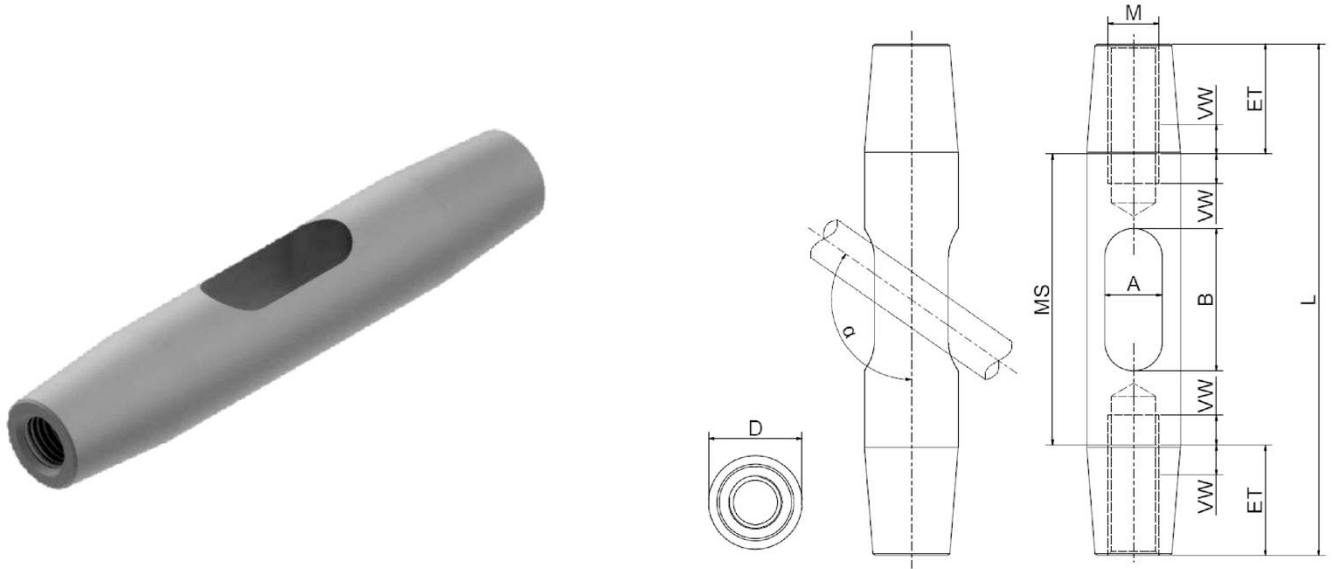

Table A12: **Dimensions Intersection Coupler STAINLESS STEEL**

Size M [mm]	Intersection Coupler							
	L [mm]	D [mm]	MS [mm]	A [mm]	B [mm]	$\alpha$ [°]	ET [mm]	$\pm$ VW [mm]
8	86	16	51	10,5	26	125	17,5	4,5
10	106	20	62	13	31	125	22	5,5
12	126	23	74	15	36	125	26	6,5
14	149	27	85	17	41	125	32	9
16	162	30	94	19	48	125	34	9
20	203	37	116	23	57	125	43,5	11,5
24	241	44	137	27	67	125	52	14
27	271	49	155	30	78	125	58	16
30	300	55	171	34	84	125	64,5	17,5
36	332	65	178	40	100	125	77	21
42	389	76	209	46	117	125	90	25
48	443	86	238	52	133	125	102,5	28,5
52	460	94	260	57	146	125	100	31
56	497	101	282	61	159	125	107,5	33,5
60	534	108	303	65	172	125	115,5	35,5
64	563	115	316	69	177	125	123,5	37,5
70	614	126	344	76	192	125	135	41
80	704	144	397	86	222	125	153,5	47,5
90	800	162	450	96	250	125	175	55
100	884	180	498	106	278	125	193	60
110	968	198	546	116	306	125	211	65
120	1055	216	595	126	335	125	230	70

**PFEIFER-Tension Rod System UMIX**

**Product Description**  
Intersection Coupler *STAINLESS STEEL*

**Annex A14**

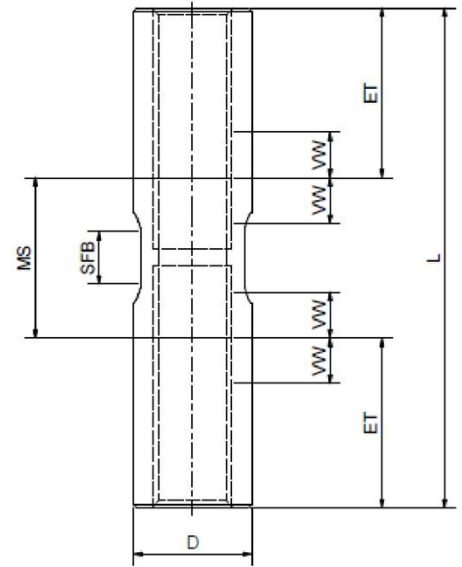
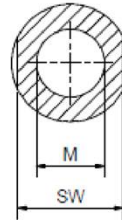

Table A13: **Dimensions Coupler STAINLESS STEEL**

Size	Coupler						
M [mm]	L [mm]	D [mm]	MS [mm]	SFB [mm]	SW [mm]	ET [mm]	±VW [mm]
8	56	12	21	12	11	17,5	4,5
10	68	15	24	12	13	22	5,5
12	80	18	28	12	16	26	6,5
14	92	21	28	12	19	32	9
16	104	24	36	16	22	34	9
20	129	30	42	16	27	43,5	11,5
24	153	36	49	16	32	52	14
27	171	40,5	55	16	36	58	16
30	196	45	67	20	40	64,5	17,5
36	232	54	78	20	49	77	21
42	269	63	89	20	57	90	25
48	306	72	101	20	65	102,5	28,5
52	266	78	66	---	---	100	31
56	288	84	73	---	---	107,5	33,5
60	308	90	77	---	---	115,5	35,5
64	327	96	80	---	---	123,5	37,5
70	358	105	88	---	---	135	41
80	408	120	101	---	---	153,5	47,5
90	466	135	116	---	---	175	55
100	512	150	126	---	---	193	60
110	558	165	136	---	---	211	65
120	606	180	146	---	---	230	70

**PFEIFER-Tension Rod System UMIK**

**Product Description**  
Coupler *STAINLESS STEEL*

**Annex A15**

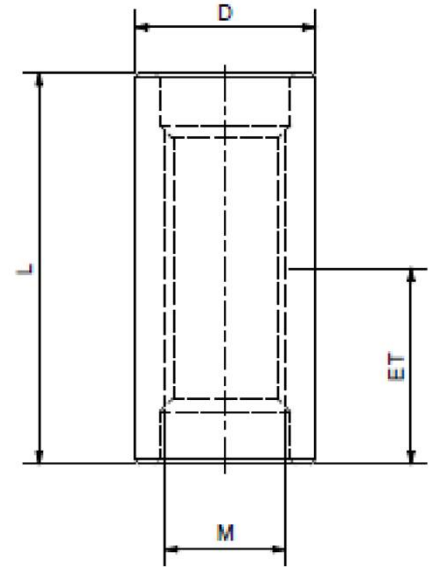

Table A14: **Dimensions Connector STAINLESS STEEL**

Size	Connector		
M [mm]	D [mm]	L [mm]	ET [mm]
8	12	28	14
10	15	35	17,5
12	18	41	20,5
14	21	47	23,5
16	24	52	26
20	30	66	33
24	36	78	39
27	40,5	85	42,5
30	42	97	48,5
36	50	114	57
42	59	132	66
48	67	150	75
52	73	159	79,5
56	79	173	86,5
60	84	183	91,5
64	89	195	97,5
70	98	210	105
80	116	234	117
90	130	258	129
100	145	282	141
110	160	306	153
120	174	330	165

**PFEIFER-Tension Rod System UMIK**

**Product Description**  
Connector *STAINLESS STEEL*

**Annex A16**



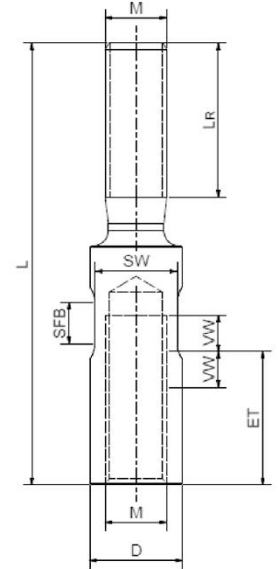

Table A15: **Dimensions Adapter STAINLESS STEEL**

Size	Adapter						
M [mm]	L [mm]	D [mm]	L <sub>R</sub> [mm]	SFB [mm]	SW [mm]	ET [mm]	±VW [mm]
8	60	12	20	12	11	17,5	4,5
10	74	15	25	12	13	22	5,5
12	89	18	30	12	16	26	6,5
14	107	21	37	12	19	32	9
16	113,5	24	39	16	22	34	9
20	144	30	50	16	27	43,5	11,5
24	172	36	60	16	32	52	14
27	191	40,5	68	16	36	58	16
30	214	45	75	20	40	64,5	17,5
36	242	54	90	20	49	77	21
42	283	63	106	20	57	90	25
48	322	72	121	20	65	102,5	28,5
52	336	78	131	---	---	100	31
56	362	84	141	---	---	107,5	33,5
60	380	90	151	---	---	115,5	35,5
64	412	96	161	---	---	123,5	37,5
70	459	105	176	---	---	135	41
80	520	120	201	---	---	153,5	47,5
90	586	135	230	---	---	175	55
100	643	150	253	---	---	193	60
110	691	165	276	---	---	211	65
120	750	180	300	---	---	230	70

**PFEIFER-Tension Rod System UMIK**

**Product Description**  
Adapter *STAINLESS STEEL*

**Annex A17**

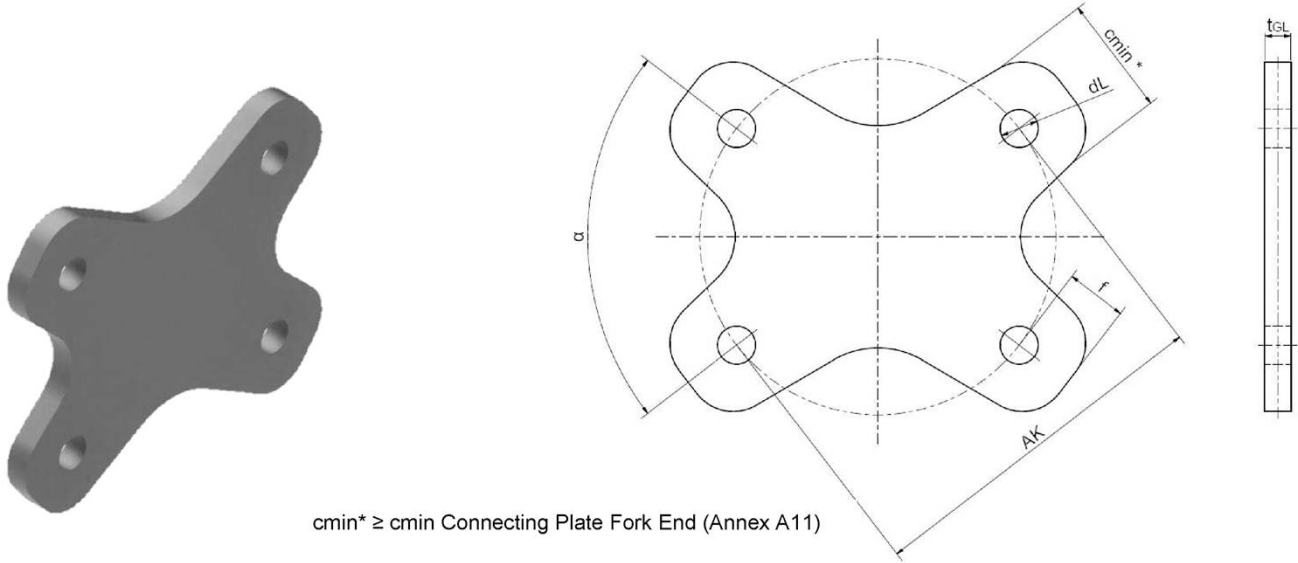

Table A16: **Dimensions Intersection Plate *STAINLESS STEEL***

Size M [mm]	Intersection Plate				
	t <sub>GL</sub> [mm]	d <sub>L</sub> [mm]	f [mm]	AK [mm]	α [°]
8	8	9	14,5	83	40-90
10	10	11	17,5	103	40-90
12	12	13,5	21,5	125	40-90
14	15	16	26	148	40-90
16	15	18	29	165	40-90
20	20	22	35	205	40-90
24	20	26	42	245	40-90
27	20	30	48	270	40-90
30	25	33	53	309	40-90
36	25	39	65	356	40-90
42	30	45	72	410	40-90
48	35	51	82	475	40-90
52	40	55	88	509	40-90
56	40	59	95	551	40-90
60	45	63	100	585	40-90
64	45	67	107	626	40-90
70	50	73	117	683	40-90
80	60	83	133	784	40-90
90	70	95	152	885	40-90
100	75	109	174	971	40-90
110	85	121	193	1080	40-90
120	95	132	210	1180	40-90

**PFEIFER-Tension Rod System UMIX**

**Product Description**  
Intersection Plate *STAINLESS STEEL*

**Annex A18**

Table A17: **Material Definition STEEL (minimum values)**

Component	Annex	Material		Yield strength $R_{p0,2}$ [N/mm <sup>2</sup> ]	Tensile strength $R_m$ [N/mm <sup>2</sup> ]	Ultimate elongation $A_s$ [%]	Impact work (ISO-V) $\alpha_k$ [J/°C]	
		Short name	Number					
Fork End	A3	EN-GJS-400-18-LT	5.3103	according EN 1563:2018				
		S355J2	1.0577	according EN 10025-2:2019				
Spade End	A4	S355J2	1.0577	according EN 10025-2:2019				
Pin	A3	34CrNiMo6+QT <sup>3)</sup>	1.6582 <sup>3)</sup>	according EN ISO 683-2:2018			27/-20	
Lock Nut	A3	S185 <sup>1)</sup>	--	--	340	--	--	
Tension Rod	Grade 3 S355	S355J2	1.0577	according EN 10025-2:2019				
		S460N	1.8901	according EN 10025-3:2019				
	Grade 2 S460	S460NL	1.8903	according EN 10025-3:2019				
		Grade 1 S530	S530 <sup>2)</sup>	--	530	710	17	27/-20
			34CrNiMo6+QT <sup>3)</sup>	1.6582 <sup>3)</sup>	530	710	12	27/-20
			42CrMo4+QT <sup>3)</sup>	1.7225 <sup>3)</sup>	530	710	12	27/-20
			42CrMoS4+QT <sup>3)</sup>	1.7227 <sup>3)</sup>	530	710	12	27/-20
			ANSI / AISI 4140 <sup>3)</sup>	--	530	710	12	27/-20
ANSI / AISI 4340 <sup>3)</sup>	--		530	710	12	27/-20		
Connecting Plate Intersection Plate	A3 A10	S355J2 <sup>1)</sup>	1.0577	according EN 10025-2/3:2019				
Intersection Coupler Coupler Connector Adapter	A6 A7 A8 A9	S530/S600 <sup>2)</sup>	--	530	710	17	27/-20	
		34CrNiMo6+QT <sup>3)</sup>	1.6582 <sup>3)</sup>	acc. to EN ISO 683-2:2018		12	27/-20	
		42CrMo4+QT <sup>3)</sup>	1.7225 <sup>3)</sup>	530	710	12	27/-20	
		42CrMoS4+QT <sup>3)</sup>	1.7227 <sup>3)</sup>	530	710	12	27/-20	

<sup>1)</sup> or higher quality

<sup>2)</sup> similar to EN 10025-3:2019

<sup>3)</sup> similar to EN ISO 683-2:2018 respectively ASTM A29/A29M

**PFEIFER-Tension Rod System UMIX**

**Product Description**  
Material Definition *STEEL* (minimum values)

**Annex A19**



Table A18: **Material Definition STAINLESS STEEL (minimum values)**

Component	Annex	Material		Yield strength $R_{p0,2}$ [N/mm <sup>2</sup> ]	Tensile strength $R_m$ [N/mm <sup>2</sup> ]	Ultimate elongation $A_s$ [%]	Impact work (ISO-V) $\alpha_k$ [J/°C]
		Short name	Number				
Fork End	A11	GX2CrNiMoN22-5-3 <sup>2)</sup>	1.4470 <sup>2)</sup>	according EN 10283:2019			30/20 or 27/-20
Spade End	A12	GX2CrNiMoN22-5-3 <sup>2)</sup>	1.4470 <sup>2)</sup>	according EN 10283:2019			30/20 or 27/-20
Pin	A11	X5CrNiCuNb16-4	1.4542	according EN 10088-5:2009			
Lock Nut	A11	X2CrNiMo17-12-2	1.4404	according EN 10088-5:2009			
Tension Rod	Grade 3 VA400	X2CrNiN23-4	1.4362	according EN 10088-3:2014			
		X2CrNiN23-4 <sup>2)</sup>	1.4362 <sup>2)</sup>	450	620	25	100/20 or 40/-40
	Grade 2 VA450	X2CrNiMoN29-7-2	1.4477	according EN 10088-3:2014			
		X2CrNiMoCuWN25-7-4	1.4501	according EN 10088-3:2014			
		X2CrNiMoN25-7-4	1.4410	according EN 10088-3:2014			
		X2CrNiMoCuN25-6-3	1.4507	according EN 10088-3:2014			
		X2CrNiMnMoCuN24-4-3-2	1.4662	according EN 10088-3:2014			
		X3CrNiMoN27-5-2	1.4460	according EN 10088-3:2014			
		X2CrNiMoN22-5-3	1.4462	according EN 10088-3:2014			
		Grade 1 VA560	X2CrNiMoN29-7-2 <sup>2)</sup>	1.4477 <sup>2)</sup>	560	710	17
	X2CrNiMoCuWN25-7-4 <sup>2)</sup>		1.4501 <sup>2)</sup>	560	710	17	100/20 or 40/-40
	X2CrNiMoN25-7-4 <sup>2)</sup>		1.4410 <sup>2)</sup>	560	710	17	100/20 or 40/-40
	X2CrNiMoCuN25-6-3 <sup>2)</sup>		1.4507 <sup>2)</sup>	560	710	17	100/20 or 40/-40
	X2CrNiMnMoCuN24-4-3-2 <sup>2)</sup>		1.4662 <sup>2)</sup>	560	710	17	100/20 or 40/-40
	X3CrNiMoN27-5-2 <sup>2)</sup>		1.4460 <sup>2)</sup>	560	710	17	100/20 or 40/-40
			X2CrNiMoN22-5-3 <sup>2)</sup>	1.4462 <sup>2)</sup>	560	710	17
Connecting Plate Intersection Plate	A11 A18	S355J2 <sup>1)</sup>	1.0577	according EN 10025-2:2019			
Intersection Coupler Coupler Connector Adapter	A14 A15 A16 A17	X2CrNiMoN29-7-2 <sup>2)</sup>	1.4477 <sup>2)</sup>	580	790	17	100/20 or 40/-40
		X2CrNiMoCuWN25-7-4 <sup>2)</sup>	1.4501 <sup>2)</sup>	580	790	17	100/20 or 40/-40
		X2CrNiMoN22-5-3 <sup>2)</sup>	1.4462 <sup>2)</sup>	580	790	17	100/20 or 40/-40

<sup>1)</sup> Alternative material similar to S355J2 considering the partial safety factor  $\gamma_{MO} = 1,1$  for stainless steel

<sup>2)</sup> similar to EN 10088-3/-5:2014

**PFEIFER-Tension Rod System UMIX**

**Product Description**  
Material Definition *STAINLESS STEEL* (minimum values)

**Annex A20**

## Intended Use

### Design assumptions

- Static or quasi-static loading
- The Tension Rod System is not allowed to be used if structures are susceptible to vibration under wind loads or wind-induced transverse vibrations of the entire structure can occur. In this context, reference is made to any applicable national regulations of the member state at the installation site.
- Bending stress in the Tension Rod System is excluded
- Observance and compliance with the dimensions, material properties and minimum engagement depths according to Annex A.
- The verification of the load-bearing capacity is based on the safety concept according to EN 1990:2002 and the resistances according to Annex C1 to C6.
- The rules given in EN 1090-2:2018 and EN ISO 12944:1998 are observed.
- The verification of the structural safety is carried out by a structural engineer experienced in the field of steel construction.

### Verification of tensile loading

The relevant design resistance  $F_{t,Rd}$  of the Tension Rod System under tensile loading is the minimum of the design resistances of the individual cross-sectional areas of the shaft or thread of the Tension Rod:

$$F_{t,Rd} = \min \left\{ \frac{F_{t,k,sch}}{\gamma_{M0}}; \frac{F_{t,k,G}}{\gamma_{M2}} \right\}$$

- Characteristic resistance  $F_{t,k,sch}$  or  $F_{t,k,G}$  according Annex C1 to C6
- The partial safety factor  $\gamma_{M0}$  and  $\gamma_{M2}$  are recommended minimum values according to EN 1993-1-1:2005+AC:2009, clause 6.1 or EN 1993-1-4:2006+A1:2015, clause 5.1. National regulations shall be observed.

### Verification of compression loading

The relevant design resistance  $F_{c,Rd}$  of the Compression Rod System with Fork Ends made of *STEEL* according to Annex A3 or A11 under compression loading is the minimum of the design resistance of the individual cross-section of the shaft respectively of the thread:

$$F_{c,Rd} = \min \{ F_{c,d,sch}; F_{c,d,G} \}$$

- Design resistance  $F_{c,d,sch}$  of the Compression Rod Systems under compression loading in the area of the shaft:  
EN 1993-1-1:2005+AC:2009

**PFEIFER-Tension Rod System UMIK**

**Annex B1**

**Intended Use**  
Design

- Design resistance  $F_{c,d,G}$  of the Compression Rod System under compression loading in the area of the thread:

$$F_{c,d,G} = \left[ \frac{\gamma_{M2}}{A_S \cdot f_{u,c,G}} + \frac{\left( \frac{B - T_{Gl}}{2} + \frac{H}{50} \right) \cdot \gamma_{M0}}{W_{pl,G} \cdot f_{y,c}} \right]^{-1}$$

mit:

$A_S$             tensile stress area of the thread

$W_{pl,G}$         plastic section modulus of the core cross section

$f_{y,c}$             characteristic value of the yield strength of the strut, where  $f_{y,c} = R_{eH}$   
 $R_{eH}$  = characteristic value of the yield strength of the strut according to product standard

$f_{u,c,G}$         characteristic value of the tension resistance of the strut, where  $f_{u,c,G} = R_m$   
 $R_m$  = characteristic value of the tensile strength of the strut according to product standard

$B, T_{Gl}, H$     see annexes A3, A11

The following partial safety factors  $\gamma_{M0}$  and  $\gamma_{M2}$  are recommended minimum values. National regulations must be observed.

$\gamma_{M0}$             = 1,00 for carbon steel according EN 1993-1-1:2005+AC:2009, clause 6.1

$\gamma_{M0}$             = 1,10 for stainless steel according EN 1993-1-4:2006+A1:2015, clause 5.1

$\gamma_{M2}$             = 1,25 according EN 1993-1-1:2005+AC:2009, clause 6.1

- Determination of the limiting compression loading according to EN 1993-1-1:2005 taking into account the bending stress due to the one-sided contact of the Connection Plates.
- Proof of the bending buckling resistance in compliance with the provisions of EN 1993-1-1:2005.

**PFEIFER-Tension Rod System UMIK**

**Annex B2**

**Intended Use  
Design**

### Tasks of the manufacturer (PFEIFER)

- Provision of an European Technical Assessment ETA for the Tension Rod System
- Provision of assembly instructions for the professional assembly of the Tension Rod System
- Packaging and delivery of the prefabricated Tension Rod System as a complete unit consisting of:
  - Tension Rod
  - components according to Annex A
  - assembly instructions
- Fork Ends for the connection of Compression Rods may be supplied separately.

### Installation instructions

- The installation is carried out exclusively in accordance with the manufacturer's specifications. The manufacturer shall hand over the corresponding installation instructions to the company carrying out the construction work.
- The delivered Tension Rod System and all components have to be checked for perfect condition. It is not allowed to use damaged components.
- It is not allowed to claim Fork Ends by sudden stresses (e.g. by hammering in the bolt).
- The minimum engagement depth of the Tension Rod has to be marked before the assembly according to Annex A and the assembly instructions by the company carrying out the construction.
- The minimum engagement depth of the Tension Rod after installation has to be verified according to Annex A and the installation instructions by the company carrying out the installation.
- A written confirmation of the minimum engagement depth according to Annex A and the installation instructions has to be established and provided by the company carrying out the construction.

### Verification

- After installation:  
The company which is responsible for carrying out the construction has to confirm that the installation was carried out in accordance with the regulations defined in this ETA.
- At regular intervals:  
Examination and inspection of the Tension Rod System incl. the individual components with regard to corrosion and completeness. The inspections must be recorded.

**PFEIFER-Tension Rod System UMIK**

#### Intended Use

Tasks of the manufactures, Installation instructions, Control

**Annex B3**

Table C1: Resistance and Partial Safety Factors ZSS Grade 1 (STEEL S530)

Type	Characteristic Resistance	Recommended Partial safety factor	Characteristic Resistance	Recommended Partial safety factor
ZSS Grade 1	Cross-sectional area shaft		Cross-sectional area thread	
[--]	$F_{t,k,sch}$ [kN]	$\gamma_{M0}$ [--]	$F_{t,k,G}$ [kN]	$\gamma_{M2}$ [--]
008	19,1	1,0	23,4	1,25
010	30,5		37,0	
012	44,3		53,8	
014	60,6		73,7	
016	82,1		100,1	
020	130,1		156,3	
024	189,6		225,1	
027	247,4		293,4	
030	301,7		358,0	
036	438,6		521,6	
042	608,8		715,9	
048	798,0		940,9	
052	972,3		1122,7	
056	1125,6		1296,5	
060	1305,4		1508,6	
064	1482,6		1709,1	
070	1795,7		2078,5	
080	2384,1		2774,4	
090	3055,8		3570,7	
100	3810,7		4467,3	
110	4648,9	5464,2		
120	5570,3	6561,5		

The relevant design resistance is the minimum of the design resistances of the individual cross-sectional areas of the shaft / thread:

$$F_{t,Rd} = \min \left\{ \frac{F_{t,k,sch}}{\gamma_{M0}}; \frac{F_{t,k,G}}{\gamma_{M2}} \right\}$$

The partial safety factors  $\gamma_{M0}$  and  $\gamma_{M2}$  are recommended minimum values according to EN 1993-1-1:2005+AC:2009, clause 6.1 and EN 1993-1-4:2006+A1:2015, clause 5.1. National regulations must be observed.

**PFEIFER-Tension Rod System UMIX**

**Performance**  
Resistances and Partial Safety Factors ZSS Grade 1 (STEEL S530)

**Annex C1**

Table C2: Resistance and Partial Safety Factors ZSS Grade 2 (STEEL S460)

Type	Characteristic Resistance	Recommended Partial safety factor	Characteristic Resistance	Recommended Partial safety factor
ZSS Grade 2	Cross-sectional area shaft		Cross-sectional area thread	
[--]	$F_{t,k,sch}$ [kN]	$\gamma_{M0}$ [--]	$F_{t,k,G}$ [kN]	$\gamma_{M2}$ [--]
008	16,6	1,0	17,8	1,25
010	26,5		28,2	
012	38,4		40,9	
014	52,6		56,1	
016	71,3		76,1	
020	108,0		118,9	
024	157,4		171,2	
027	205,4		223,2	
030	250,5		272,3	
036	364,1		396,7	
042	505,4		544,5	
048	647,5		715,6	
052	788,8		853,9	
056	913,2		986,1	
060	1059,1		1147,4	
064	1202,9		1299,9	
070	1389,1		1580,8	
080	1844,3		2110,1	
090	2306,3		2715,8	
100	2876,0		3397,7	
110	3333,2	4078,9		
120	3993,8	4898,0		

The relevant design resistance is the minimum of the design resistances of the individual cross-sectional areas of the shaft / thread:

$$F_{t,Rd} = \min \left\{ \frac{F_{t,k,sch}}{\gamma_{M0}}; \frac{F_{t,k,G}}{\gamma_{M2}} \right\}$$

The partial safety factors  $\gamma_{M0}$  and  $\gamma_{M2}$  are recommended minimum values according to EN 1993-1-1:2005+AC:2009, clause 6.1 and EN 1993-1-4:2006+A1:2015, clause 5.1. National regulations must be observed.

**PFEIFER-Tension Rod System UMIX**

**Performance**

Resistances and Partial Safety Factors ZSS Grade 2 (STEEL S460)

**Annex C2**



Table C3: Resistance and Partial Safety Factors ZSS Grade 3 (STEEL S355)

Type	Characteristic Resistance	Recommended Partial safety factor	Characteristic Resistance	Recommended Partial safety factor
ZSS Grade 3	Cross-sectional area shaft		Cross-sectional area thread	
[--]	$F_{t,k,sch}$ [kN]	$\gamma_{M0}$ [--]	$F_{t,k,G}$ [kN]	$\gamma_{M2}$ [--]
008	12,8	1,0	15,5	1,25
010	20,4		24,5	
012	29,7		35,6	
014	40,6		48,8	
016	55,0		66,2	
020	84,7		103,5	
024	123,4		149,0	
027	161,0		194,2	
030	196,4		237,0	
036	285,5		345,3	
042	396,3		473,9	
048	504,4		622,8	
052	614,6		743,2	
056	711,4		858,3	
060	825,1		998,6	
064	937,1		1131,4	
070	1101,1		1375,9	
080	1462,0		1836,6	
090	1816,2		2363,7	
100	2264,9		2957,2	
110	2587,6	3463,2		
120	3100,5	4158,7		

The relevant design resistance is the minimum of the design resistances of the individual cross-sectional areas of the shaft / thread:

$$F_{t,Rd} = \min \left\{ \frac{F_{t,k,sch}}{\gamma_{M0}}; \frac{F_{t,k,G}}{\gamma_{M2}} \right\}$$

The partial safety factors  $\gamma_{M0}$  and  $\gamma_{M2}$  are recommended minimum values according to EN 1993-1-1:2005+AC:2009, clause 6.1 and EN 1993-1-4:2006+A1:2015, clause 5.1. National regulations must be observed.

**PFEIFER-Tension Rod System UMIX**

**Performance**  
Resistances and Partial Safety Factors ZSS Grade 3 (STEEL S355)

**Annex C3**

Table C4: Resistance and Partial Safety Factors ZSE Grade 1 (STAINLESS STEEL VA560)

Type	Characteristic Resistance	Recommended Partial safety factor	Characteristic Resistance	Recommended Partial safety factor
ZSE Grade 1	Cross-sectional area shaft		Cross-sectional area thread	
[--]	$F_{t,k,sch}$ [kN]	$\gamma_{M0}$ [--]	$F_{t,k,G}$ [kN]	$\gamma_{M2}$ [--]
008	20,9	1,1	23,4	1,25
010	33,3		37,0	
012	47,8		53,8	
014	65,2		73,7	
016	88,7		100,1	
020	140,2		156,3	
024	202,7		225,1	
027	263,7		293,4	
030	320,8		358,0	
036	465,7		521,6	
042	646,4		715,9	
048	845,2		940,9	
052	1030,3		1122,7	
056	1192,5		1296,5	
060	1382,7		1508,6	
064	1569,7		1709,1	
070	1900,8		2078,5	
080	2523,1		2774,4	
090	3233,3		3570,7	
100	4031,5		4467,3	
110	4913,0	5464,2		
120	5886,7	6561,5		

The relevant design resistance is the minimum of the design resistances of the individual cross-sectional areas of the shaft / thread:

$$F_{t,Rd} = \min \left\{ \frac{F_{t,k,sch}}{\gamma_{M0}}; \frac{F_{t,k,G}}{\gamma_{M2}} \right\}$$

The partial safety factors  $\gamma_{M0}$  and  $\gamma_{M2}$  are recommended minimum values according to EN 1993-1-1:2005+AC:2009, clause 6.1 and EN 1993-1-4:2006+A1:2015, clause 5.1. National regulations must be observed.

**PFEIFER-Tension Rod System UMIX**

**Performance**

Resistances and Partial Safety Factors ZSE Grade 1 (STAINLESS STEEL VA560)

**Annex C4**



Table C5: Resistance and Partial Safety Factors ZSE Grade 2 (STAINLESS STEEL VA450)

Type	Characteristic Resistance	Recommended Partial safety factor	Characteristic Resistance	Recommended Partial safety factor
ZSE Grade 2	Cross-sectional area shaft		Cross-sectional area thread	
[--]	$F_{t,k,sch}$ [kN]	$\gamma_{M0}$ [--]	$F_{t,k,G}$ [kN]	$\gamma_{M2}$ [--]
008	16,8	1,1	20,4	1,25
010	26,8		32,3	
012	38,4		47,0	
014	52,4		64,4	
016	71,2		87,4	
020	112,6		136,5	
024	162,9		196,6	
027	211,9		256,2	
030	257,8		312,6	
036	374,3		455,5	
042	519,4		625,1	
048	679,2		821,6	
052	827,9		980,4	
056	958,2		1132,2	
060	1111,1		1317,3	
064	1261,3		1492,4	
070	1527,4		1815,0	
080	2027,5		2422,8	
090	2598,2		3118,1	
100	3239,6		3901,0	
110	3947,9	4771,6		
120	4730,4	5729,7		

The relevant design resistance is the minimum of the design resistances of the individual cross-sectional areas of the shaft / thread:

$$F_{t,Rd} = \min \left\{ \frac{F_{t,k,sch}}{\gamma_{M0}}; \frac{F_{t,k,G}}{\gamma_{M2}} \right\}$$

The partial safety factors  $\gamma_{M0}$  and  $\gamma_{M2}$  are recommended minimum values according to EN 1993-1-1:2005+AC:2009, clause 6.1 and EN 1993-1-4:2006+A1:2015, clause 5.1. National regulations must be observed.

**PFEIFER-Tension Rod System UMIX**

**Performance**

Resistances and Partial Safety Factors ZSE Grade 2 (STAINLESS STEEL VA450)

**Annex C5**

Table C6: Resistance and Partial Safety Factors ZSE Grade 3 (STAINLESS STEEL VA400)

Type	Characteristic Resistance	Recommended Partial safety factor	Characteristic Resistance	Recommended Partial safety factor
ZSE Grade 3	Cross-sectional area shaft		Cross-sectional area thread	
[--]	$F_{t,k,sch}$ [kN]	$\gamma_{M0}$ [--]	$F_{t,k,G}$ [kN]	$\gamma_{M2}$ [--]
008	14,9	1,1	19,8	1,25
010	23,8		31,3	
012	34,1		45,5	
014	46,6		62,3	
016	63,3		84,6	
020	100,1		132,1	
024	144,8		190,3	
027	188,4		248,0	
030	229,1		302,6	
036	332,7		440,8	
042	461,7		605,0	
048	603,7		795,1	
052	735,9		948,7	
056	851,8		1095,7	
060	987,7		1274,8	
064	1121,2		1444,3	
070	1357,7		1756,5	
080	1802,2		2344,6	
090	2309,5		3017,5	
100	2879,6		3775,2	
110	3509,3	4617,7		
120	4204,8	5544,9		

The relevant design resistance is the minimum of the design resistances of the individual cross-sectional areas of the shaft / thread:

$$F_{t,Rd} = \min \left\{ \frac{F_{t,k,sch}}{\gamma_{M0}}; \frac{F_{t,k,G}}{\gamma_{M2}} \right\}$$

The partial safety factors  $\gamma_{M0}$  and  $\gamma_{M2}$  are recommended minimum values according to EN 1993-1-1:2005+AC:2009, clause 6.1 and EN 1993-1-4:2006+A1:2015, clause 5.1. National regulations must be observed.

**PFEIFER-Tension Rod System UMIX**

**Performance**

Resistances and Partial Safety Factors ZSE Grade 3 (STAINLESS STEEL VA400)

**Annex C6**