

Approval body for construction products
and types of construction

Bautechnisches Prüfamt

An institution established by the Federal and
Laender Governments



European Technical Assessment

ETA-19/0730 of

English translation prepared by DIBt - Original version in German language

General Part

Technical Assessment Body issuing the
European Technical Assessment:

Deutsches Institut für Bautechnik

Trade name of the construction product

HENSOTHERM RM30
HENSOTHERM RM50

Product family
to which the construction product belongs

Construction Product for use in Penetration Seals - Pipe
Collar

Manufacturer

Rudolf Hensel GmbH
Lauenburger Landstraße 11
21039 Börnsen
DEUTSCHLAND

Manufacturing plant

H01¹

This European Technical Assessment
contains

9 pages including 5 annexes which form an integral part
of this assessment

This European Technical Assessment is
issued in accordance with Regulation (EU)
No 305/2011, on the basis of

350454-00-1104

This version replaces

ETA-19/0730 of 30/01/2020

¹ Address known at DIBt

The European Technical Assessment is issued by the Technical Assessment Body in its official language. Translations of this European Technical Assessment in other languages shall fully correspond to the original issued document and shall be identified as such.

Communication of this European Technical Assessment, including transmission by electronic means, shall be in full. However, partial reproduction may only be made with the written consent of the issuing Technical Assessment Body. Any partial reproduction shall be identified as such.

This European Technical Assessment may be withdrawn by the issuing Technical Assessment Body, in particular pursuant to information by the Commission in accordance with Article 25(3) of Regulation (EU) No 305/2011.

Specific Part

1 Technical description of the product

"HENSOTHERM RM30" and "HENSOTHERM RM50" are pipe collars consisting of a pipe collar enclosure and a fire-protective inlay.

The pipe collar enclosure is made of sheet steel and needs to be sufficiently protected against corrosion. The fire-protective inlay is made of a multi-layer fire-protective inlay made of an intumescent material, which expands under heat exposure.

The pipe collar has the dimensions given in Annexes 2 and 3.

A detailed technical description of the fire safety related performance criteria for the construction products is given in Annexes 1 to 5. Detailed information on the construction products' components is deposited with Deutsches Institut für Bautechnik.

NOTE:

The characteristics listed are suitable both for identifying the construction products as well as for performing the manufacturer's factory production control.

2 Specification of the intended use in accordance with the applicable European Assessment Document

The pipe collars "HENSOTHERM RM30" and "HENSOTHERM RM50" are intended for use as a component of a pipe penetration seal for plastic pipes.

Pipe penetration seals are used to seal openings in fire-resistant walls and floors, which are penetrated by pipes. Their aim is to preserve the walls' or floors' fire resistance in the area of the penetrations.

This ETA has served to verify the resistance to fire of pipe penetration seals containing two pipe collars (for wall installations) or one pipe collar (for floor installations). The pipe penetration seals also consisted of a seal between the penetrating pipe and the circular edge of the surrounding building element.

More detailed information and data on the verified penetration seals are given in annexes 4 and 5.

The performances given in Section 3 apply exclusively to the penetration seals assessed as part of the ETA procedure (e.g. with respect to the design and arrangement of the penetration seals' components as well as the type and position of the services).

The verifications and assessment methods on which this European Technical Assessment is based lead to the assumption of a working life of the pipe collars of 10 years. The indications given on the working life cannot be interpreted as a guarantee given by the producer, but are to be regarded only as a means for choosing the right products in relation to the expected economically reasonable working life of the works.

3 Performance of the product and references to the methods used for its assessment

3.1 Safety in case of fire (BWR 2)

3.1.1 Reaction to fire

Component	Performance
Enclosure material: steel sheet	Class A1 in accordance with the Decision of the Commission N° 1996/603/EC (current version)

Component	Performance
Inlay material: intumescent material in acc. with ETA-16/0369	Class E in accordance with EN 13501-1 ²

3.1.2 Resistance to fire

Essential characteristic	Performance
Resistance to fire of a penetration seal containing the product	The resistance to fire depends on the design and installation of the penetration seal and on the other components that make up the penetration seal. More details on the tested penetration seals and the related fire resistance classes are given in Annexes 1 to 5.

3.2 Hygiene, health and the environment (BWR 3)

The construction product does not contain any dangerous substances³ in accordance with the regulation (EU) N° 1272/2008 of European Parliament and of the Council of 16 December 2008⁴.

The chemical composition of the product has to accord with those deposited with DIBt.

3.3 Safety and accessibility in use (BWR 4)

3.3.1 Durability

The construction products "HENSOTHERM RM30" and "HENSOTHERM RM50" may be used for penetration seals of use category type X (outdoor use – rain, UV light, frost) provided that the other components of the penetration seal, which are not the subject of this ETA, meet the durability requirements.

4 Assessment and verification of constancy of performance (AVCP) system applied, with reference to its legal base

In accordance with European Assessment Document (EAD) no. 350454-00-1104, the following legal base shall apply: 1999/454/EC.

The system to be applied is: system 1.

5 Technical details necessary for the implementation of the AVCP system, as provided for in the applicable EAD

Technical details necessary for the implementation of the AVCP system are laid down in the control plan deposited with Deutsches Institut für Bautechnik.

Issued in Berlin on 16. August 2024 by Deutsches Institut für Bautechnik

Johanna Bartling
Head of Department

beglaubigt:
Meske-Dallal

² EN 13501-1:2018 Fire classification of construction products and building elements - Part 1: Classification using test data from reaction to fire tests

³ The chemical composition shall be identical to the composition deposited with DIBt.

⁴ Official Journal of the EU N° L 353 of 31 December 2008, p. 1

The factory manufactured construction products pipe collar "HENSOTHERM RM30" and "HENSOTHERM RM50" consists of a pipe collar steel housing and an inlay of a multi-layer intumescent material which is incorporated in the pipe collar housing.

Properties and performance criteria of the components of the construction product "HENSOTHERM RM30" and "HENSOTHERM RM50"

Component	Description
"Pipe collar housing"	Dimensions: see Annexes 2 and 3 Material: sheet steel Classification of the fire behavior: Class A1 according to the commission decision 96/603/EC (current version)
"Inlay"	Dimensions: see Annexes 2 and 3 Material: Intumescent building material according to ETA-16/0369 Classification of the fire behavior according to EN 13501-1: Class E

The properties listed can be used for the identification of the construction product and for the implementation of the factory production control of the manufacturer.

Implementation details for the factory production control are included in the inspection plan.

Description of the additional components of the tested sealings

Sealing of the residual joint between pipe collar and soffit: Gypsum mortar	Classification of the fire behavior: Class A1 according to the commission decision 96/603/EC (in the current version)
--	---

Performance of penetration seals, comprising the construction product "HENSOTHERM RM30" and "HENSOTHERM RM50"

	Essential requirement	Test method	Construction of the sample	Performance
1	Resistance to fire	EN 1366-3	100 mm thick flexible wall; design and layout of the penetration seal according to Annex 4	s. Annex 4
2	Resistance to fire	EN 1366-3	150 mm thick rigid floor; design and layout of the penetration seal according to Annex 5	s. Annex 5

The tested/ illustrated seals are only examples for the use.

The illustrations on page 4 and 5 are without guarantee for completeness.

The use of the construction product "HENSOTHERM RM30" and "HENSOTHERM RM50" in penetration seals shall be in accordance with national requirements for planning, design and execution and in accordance with the installation instruction of the manufacturer.

HENSOTHERM RM30
HENSOTHERM RM50

Description of the construction products, properties and performances

Annex 1

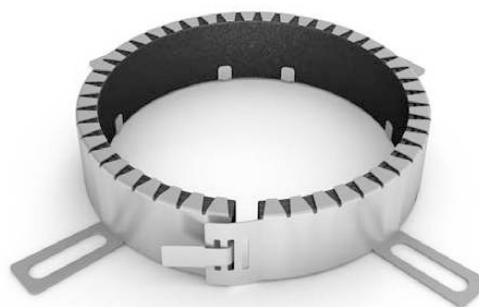
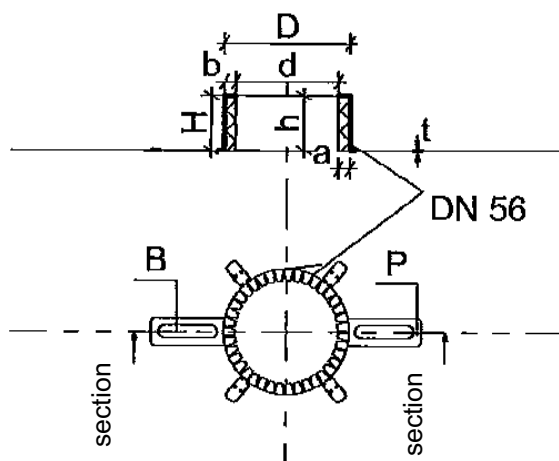

d = diameter without gap between the ends of the intumescent inlay
 d1 = diameter, if lug is fixed in slit 1
 d2 = diameter, if lug is fixed in slit 2
 d3 = diameter, if lug is fixed in slit 3

HENSOTHERM RM30

dA [mm]	d [mm]	D [mm]	b [mm]	t [mm]	H [mm]	P [number]	h [mm]	a [mm]	Layers Inlay	B [mm]	d1 [mm]	d2 [mm]	d3 [mm]
40	40,7	53,7	6,5	0,5	30	2	28	6	2	7 x 32 (R3,5)	42,6	44,2	45,8
56	56,4	69,4	6,5	0,5	30	2	28	6	2	7 x 32 (R3,5)	58,3	59,9	61,5
63	66,0	85,0	9,5	0,5	30	2	28	9	3	7 x 32 (R3,5)	73,9	75,5	77,1
75	76,9	95,9	9,5	0,5	30	3	28	9	3	7 x 32 (R3,5)	84,8	86,4	87,9
90	93,1	112,1	9,5	0,5	30	3	28	9	3	7 x 32 (R3,5)	101,0	102,6	104,2
110	113,8	132,8	9,5	0,5	30	4	28	9	3	7 x 32 (R3,5)	121,7	123,3	124,9
125	125,6	150,6	12,5	0,5	30	4	28	12	4	7 x 32 (R3,5)	139,5	141,1	142,7

HENSOTHERM RM30
HENSOTHERM RM50

Design and dimensions of pipe collar "HENSOTHERM RM30"

Annex 2

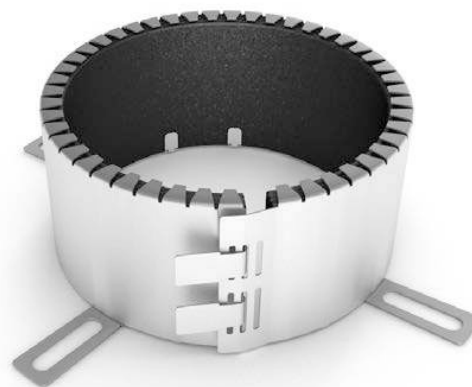
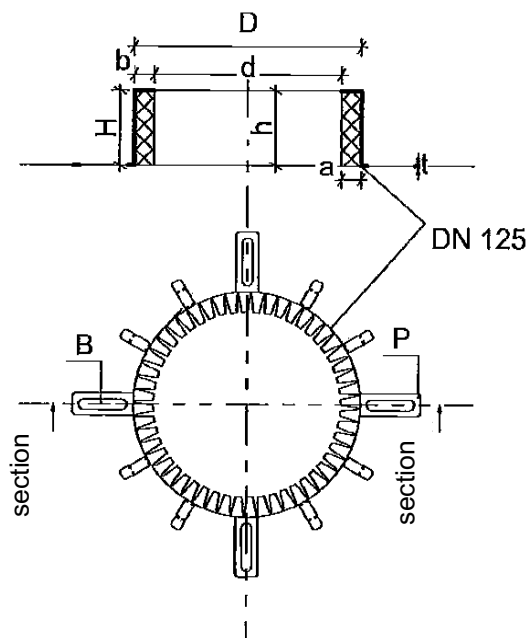

d = diameter without gap between the ends of the intumescent inlay
d1 = diameter, if lugs are fixed in slit 1
d2 = diameter, if lugs are fixed in slit 2
...
d5 = diameter, if lugs are fixed in slit 5

HENSOTHERM RM50

dA [mm]	d [mm]	D [mm]	b [mm]	t [mm]	H [mm]	P [number]	h [mm]	a [mm]	Layers Inlay	B [mm]	d1 [mm]	d2 [mm]	d3 [mm]	d4 [mm]	d5 [mm]
40	40,7	53,7	6,5	0,5	50	2	48	6	2	7 x 32 (R3,5)	42,6	44,2	45,8		
56	56,4	69,4	6,5	0,5	50	2	48	6	2	7 x 32 (R3,5)	58,3	59,9	61,5		
63	66,0	85,0	9,5	0,5	50	2	48	9	3	7 x 32 (R3,5)	73,9	75,5	77,1		
75	76,9	95,9	9,5	0,5	50	3	48	9	3	7 x 32 (R3,5)	84,8	86,4	87,9		
90	93,1	112,1	9,5	0,5	50	3	48	9	3	7 x 32 (R3,5)	101,0	102,6	104,2		
110	113,8	132,8	9,5	0,5	50	4	48	9	3	7 x 32 (R3,5)	121,7	123,3	124,9		
125	125,6	150,6	12,5	0,5	50	4	48	12	4	7 x 32 (R3,5)	139,5	141,1	142,7		
140	143,9	169,5	12,8	0,8	50	4	48	12	4	7 x 32 (R3,5)	157,8	159,4	161,0		
160	162,1	193,7	15,8	0,8	50	5	48	15	5	7 x 32 (R3,5)	182,0	183,6	185,2		
180	181,8	213,4	15,8	0,8	50	5	48	15	5	7 x 32 (R3,5)	183,7	185,3	186,9		
200	202,7	240,3	18,8	0,8	50	5	48	18	6	7 x 32 (R3,5)	204,6	206,2	207,8		
225	228,2	271,8	21,8	0,8	50	6	48	21	7	7 x 32 (R3,5)	234,9	236,5	238,1	239,7	241,3
250	251,9	301,5	24,8	0,8	50	7	48	24	8	7 x 32 (R3,5)	262,7	264,3	265,9	267,4	269

HENSOTHERM RM30
HENSOTHERM RM50

Design and dimensions of pipe collar "HENSOTHERM RM50"

Annex 3

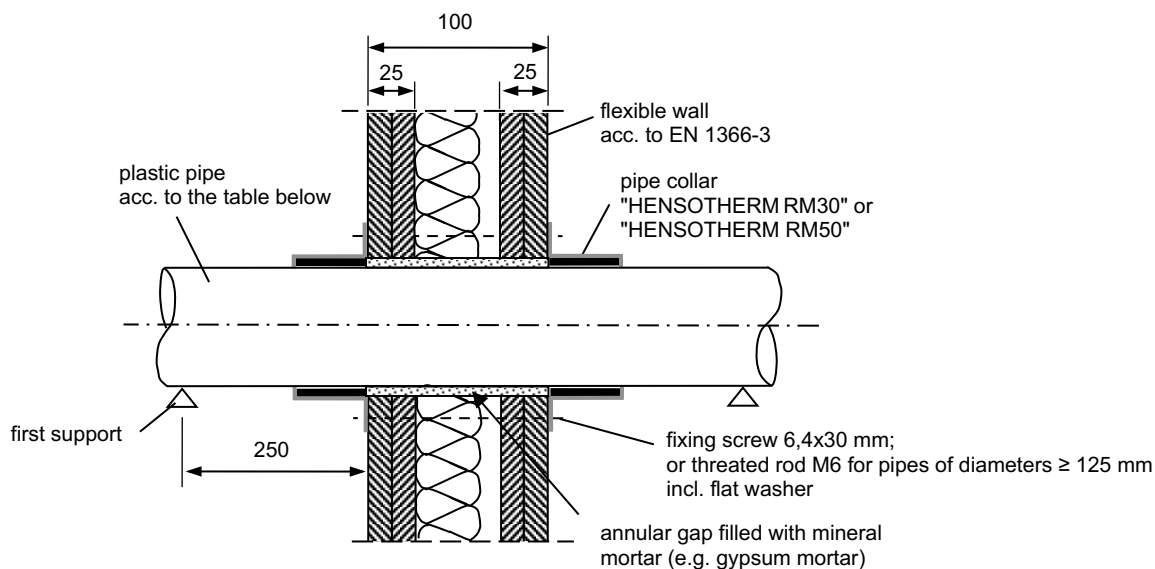

Test	Pipe N°	Type of pipe	Dimensions	Pipe collar	Classification
R000283	11	PVC-U	50 x 1,8	RM 30	EI 180-U/U
	12	PVC-U	50 x 5,6	RM 30	EI 120-U/U
	13	PVC-U	110 x 2,2	RM 30	EI 90-U/U
	14	PVC-U	110 x 8,1	RM 30	EI 90-U/C
	15	PVC-U	125 x 2,5	RM 30	EI 120-U/U
	16	PVC-U	125 x 9,3	RM 30	EI 90-U/C
R002353	4	"Geberit Silent PP"	50 x 1,8	RM 30	EI 180-U/U
	5	"Geberit Silent PP"	110 x 3,6	RM 30	EI 120-U/U
	6	"Geberit Silent PP"	125 x 4,2	RM 30	EI 180-U/U
	7	"Geberit Silent PP"	160 x 5,2	RM 50	EI 180-U/U
R002353	21	"Pipelife Master 3"	50 x 1,8	RM 30	EI 180-U/U
	22	"Pipelife Master 3"	110 x 3,6	RM 30	EI 120-U/U
	23	"Pipelife Master 3"	125 x 4,2	RM 30	EI 120-U/U

dimensions in mm

HENSOTHERM RM30
HENSOTHERM RM50

Examples for pipe penetration seals of a fire resistance class EI 90 resp. EI 120 resp. EI 180 using pipe collar "HENSOTHERM RM30" or "HENSOTHERM RM50"

Annex 4

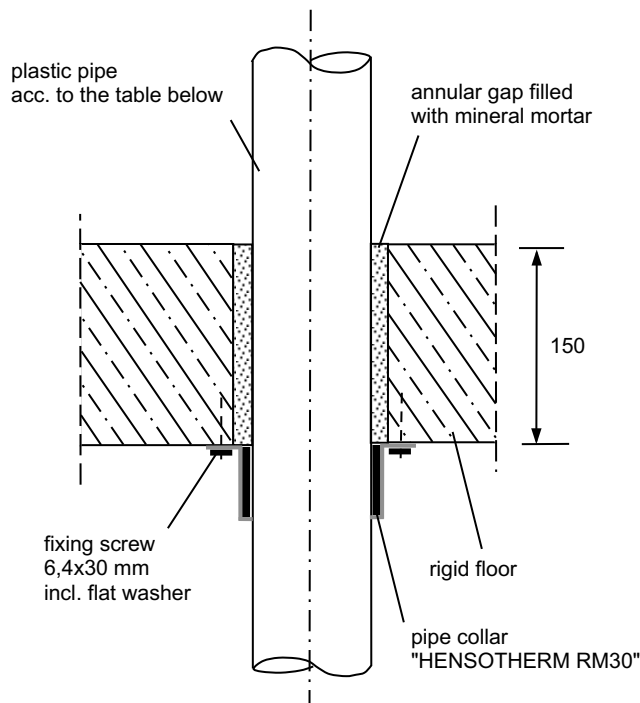

Test	Pipe N°	Type of pipe	Dimensions	Pipe collar	Classification
R000256	20	PVC-U	50 x 1,8	RM 30	EI 120-U/U
	21	PVC-U	50 x 5,6	RM 30	EI 60-U/U
	22	PVC-U	110 x 2,2	RM 30	EI 120-U/U
	23	PVC-U	110 x 8,1	RM 30	EI 120-U/C
	24	PVC-U	125 x 2,5	RM 30	EI 120-U/U
	25	PVC-U	125 x 9,3	RM 30	EI 120-U/C
	4	"Geberit Silent PP"	110 x 3,6	RM 30	EI 90-U/U
	5	"Geberit Silent PP"	125 x 4,2	RM 30	EI 120-U/U
	15	"Pipelife Master 3"	50 x 1,8	RM 30	EI 120-U/U
	16	"Pipelife Master 3"	110 x 3,6	RM 30	EI 120-U/U
17	"Pipelife Master 3"	125 x 4,2	RM 30	EI 120-U/U	

dimensions in mm

HENSOTHERM RM30
HENSOTHERM RM50

Examples for pipe penetration seals of a fire resistance class EI 60 resp. EI 90 resp. EI 120 using pipe collar "HENSOTHERM RM30"

Annex 5