

Public-law institution jointly founded by the federal states and the Federation

European Technical Assessment Body
for construction products



European Technical Assessment

ETA-19/0814
of 29 April 2024

English translation prepared by DIBt - Original version in German language

General Part

Technical Assessment Body issuing the European Technical Assessment:

Deutsches Institut für Bautechnik

Trade name of the construction product

Peikko PPM L Anchor Bolts

Product family to which the construction product belongs

Cast-in anchor bolt

Manufacturer

PEIKKO GROUP CORPORATION
Voimakatu 3
15101 Lahti
FINNLAND

Manufacturing plant

Peikko Herstellwerke
Peikko Manufacturing Plants

This European Technical Assessment contains

12 pages including 3 annexes which form an integral part of this assessment

This European Technical Assessment is issued in accordance with Regulation (EU) No 305/2011, on the basis of

EAD 330924-01-0601, Edition 07/2022

This version replaces

ETA-19/0814 issued on 17 August 2022

The European Technical Assessment is issued by the Technical Assessment Body in its official language. Translations of this European Technical Assessment in other languages shall fully correspond to the original issued document and shall be identified as such.

Communication of this European Technical Assessment, including transmission by electronic means, shall be in full. However, partial reproduction may only be made with the written consent of the issuing Technical Assessment Body. Any partial reproduction shall be identified as such.

This European Technical Assessment may be withdrawn by the issuing Technical Assessment Body, in particular pursuant to information by the Commission in accordance with Article 25(3) of Regulation (EU) No 305/2011.

Specific Part

1 Technical description of the product

The Peikko PPM L Anchor Bolts consists of a central threaded bar of the diameters 30, 36, 39, 45, 52 and 60 mm, two hexagon nuts and two washers. Two, three or four anchor bars made of ribbed reinforcing steel B500B are welded to one end of the central threaded bar. At the other end of the anchor bar a head is forged.

The anchor bolt is embedded in concrete up to the embedment depth.

The product description is given in Annex A.

2 Specification of the intended use in accordance with the applicable European Assessment Document

The performances given in Section 3 are only valid if the anchor is used in compliance with the specifications and conditions given in Annex B.

The verifications and assessment methods on which this European Technical Assessment is based lead to the assumption of a working life of the anchor of at least 50 years. The indications given on the working life cannot be interpreted as a guarantee given by the producer, but are to be regarded only as a means for choosing the right products in relation to the expected economically reasonable working life of the works.

3 Performance of the product and references to the methods used for its assessment

3.1 Mechanical resistance and stability (BWR 1)

Essential characteristic	Performance
Characteristic resistance under static and quasi-static tension load	See Annex B2 and C1
Characteristic resistance under static and quasi-static shear load	See Annex C2
Combined tension and shear under static and quasi-static load	See Annex C2
Displacement under static and quasi-static tension or shear load	See Annex C2

3.2 Safety in case of fire (BWR 2)

Essential characteristic	Performance
Reaction to fire	Class A1
Resistance to fire	No performance assessed

4 Assessment and verification of constancy of performance (AVCP) system applied, with reference to its legal base

In accordance with EAD No. 330924-01-0601, the applicable European legal act is: [96/582/EC].

The system to be applied is: 1

5 Technical details necessary for the implementation of the AVCP system, as provided for in the applicable EAD

Technical details necessary for the implementation of the AVCP system are laid down in the control plan deposited with Deutsches Institut für Bautechnik.

Issued in Berlin on 29 April 2024 by Deutsches Institut für Bautechnik

Dipl.-Ing. Beatrix Wittstock
Head of Section

beglaubigt:
Müller

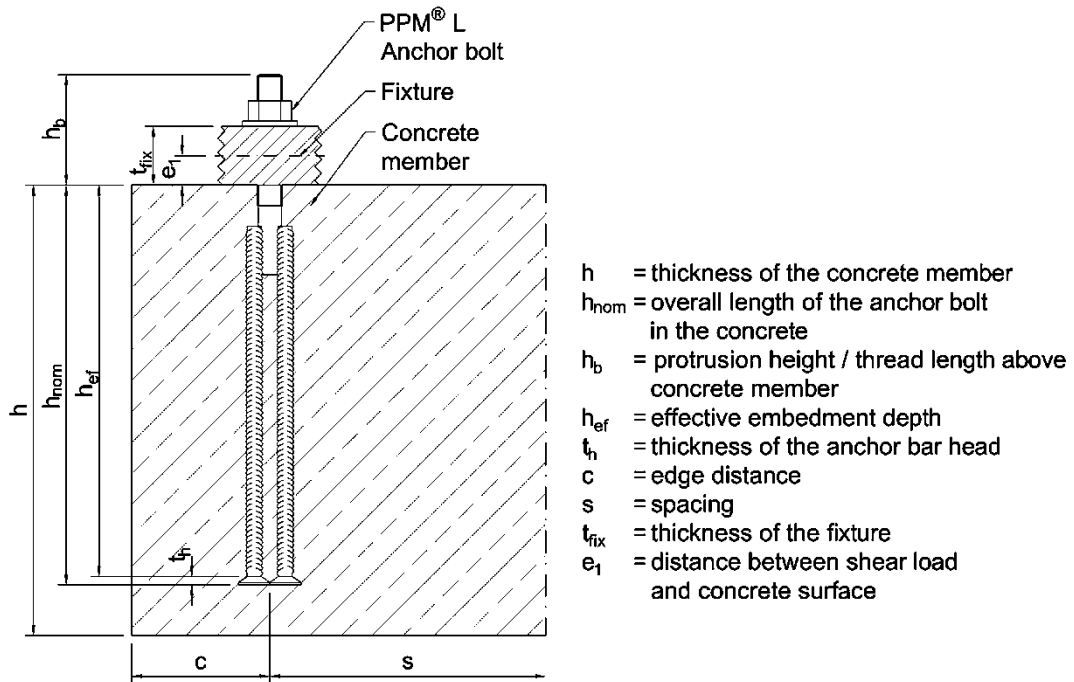

Figure 1. (a) General installation

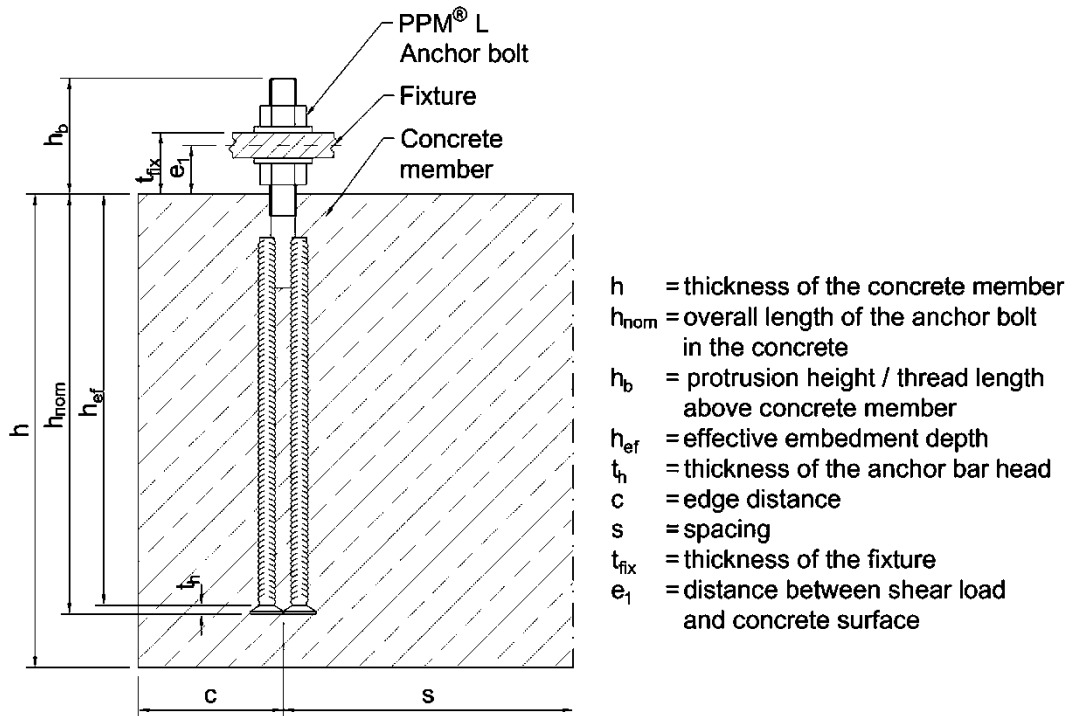

Figure 2. (b) Steel to steel contact

Peikko PPM® L Anchor Bolts	
Product description Installed conditions	Annex A1

English translation prepared by DIBt

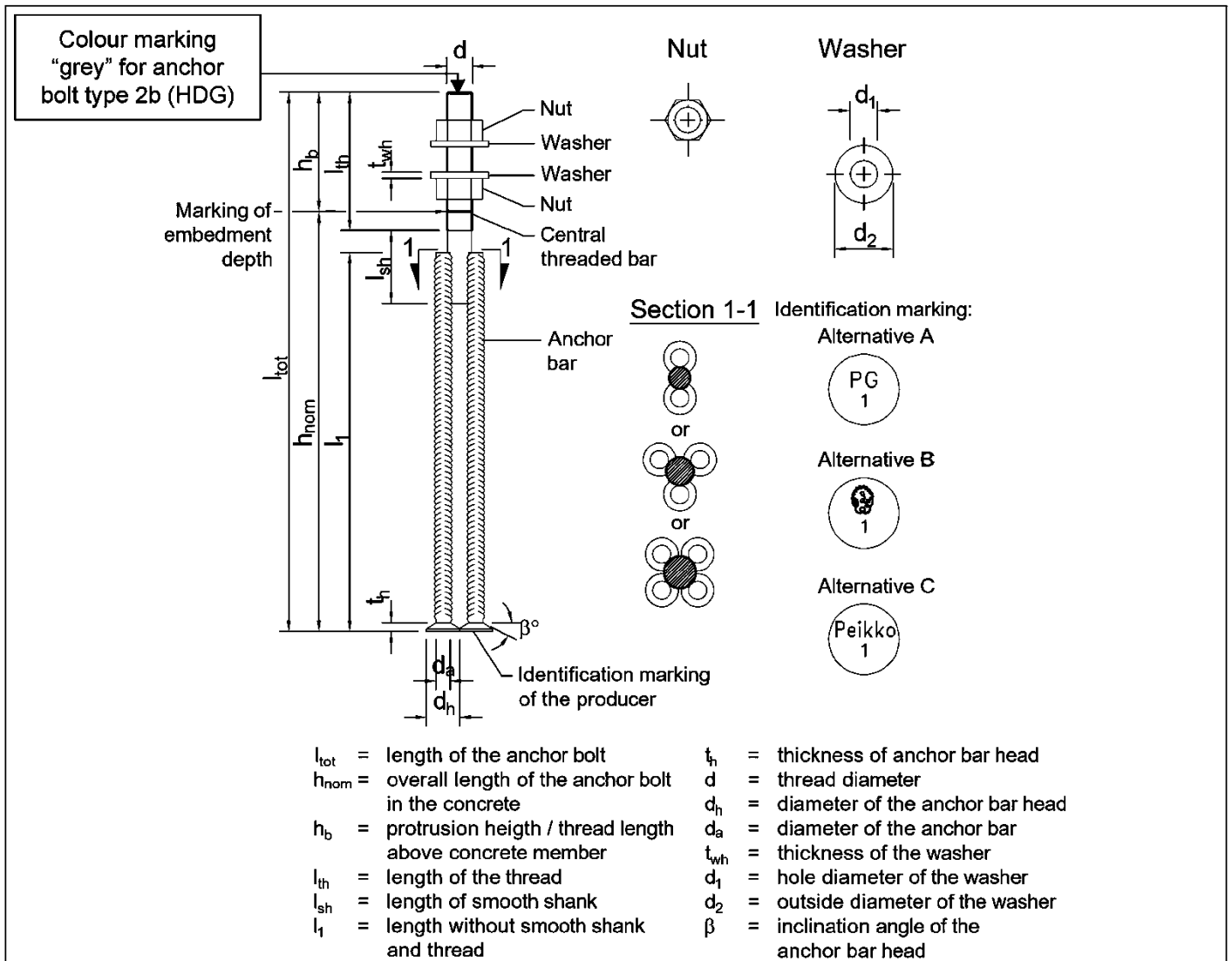

Figure 3. Dimensions of PPM® L Anchor bolts

Table 1: Dimensions

Anchor bolt	Anchor bars / Central threaded bar											Washer			Nut ¹⁾	
	n_a	d_a	d_h	d	l_{tot}	h_{nom}	h_b	l_1	$l_{th}^{2)}$	l_{sh}	t_h	A_h	d_1	d_2	t_{wh}	
	[-]	[mm]	[mm]	[mm]	[mm]	[mm]	[mm]	[mm]	[mm]	[mm]	[mm]	[mm ²]	[mm]	[mm]	[mm]	[-]
PPM® 30 L	2	25	55	30	670	535	135	515	190	100	13	3770	32	65	8	M30
PPM® 36 L	4	20	46	36	740	580	160	570	190	100	12	5391	39	80	8	M36
PPM® 39 L	3	25	55	39	880	705	175	690	190	125	13	5655	41	90	10	M39
PPM® 45 L	4	25	55	45	980	790	190	780	220	105	13	7540	47	100	10	M45
PPM® 52 L	4	32	70	52	1140	920	220	905	250	120	15	12177	54	100	12	M52
PPM® 60 L	4	32	70	60	1330	1070	260	1070	310	150	15	12177	62	115	15	M60

1) Dimensions according EN ISO 4032:2012

2) Minimum thread length l_{th} , Alternative: continuous thread

Peikko PPM® L Anchor Bolts

Product description
Dimensions, components and product marking

Annex A2

Table 2: Materials of PPM® L Anchor bolts

Part	Type	Material	Mechanical properties
Central threaded bar	2a	PPM® ** L	High strength steel, weldable $f_{uk} \geq 800 \text{ N/mm}^2$ $f_{yk} \geq 640 \text{ N/mm}^2$
	2b	PPM® ** L-HDG	High strength steel, weldable, hot dip galvanized according to EN ISO 1461:2022 or EN ISO 10684:2004 + AC:2009 $f_{uk} \geq 800 \text{ N/mm}^2$ $f_{yk} \geq 640 \text{ N/mm}^2$
Anchor bars	2a	PPM® ** L	Reinforcing steel B500B or B500C according to EN 1992-1-1:2004+AC:2010+A1:2014, Annex C $f_{uk} \geq 550 \text{ N/mm}^2$ $f_{yk} \geq 500 \text{ N/mm}^2$ according to EN 1992-1-1:2004 +AC:2010+A1:2014, Annex C
	2b	PPM® ** L-HDG	Reinforcing steel B500B or B500C according to EN 1992-1-1:2004+AC:2010+A1:2014, Annex C, hot dip galvanized according to EN ISO 1461:2022 or EN ISO 10684:2004 + AC:2009 $f_{uk} \geq 550 \text{ N/mm}^2$ $f_{yk} \geq 500 \text{ N/mm}^2$ according to EN 1992-1-1:2004 +AC:2010+A1:2014, Annex C
Hexagonal nut	2a	PPM® ** L	According to EN ISO 4032:2012 Strength class 8 according to EN ISO 898-2:2012
	2b	PPM® ** L-HDG	According to EN ISO 4032:2012, hot dip galvanized according to EN ISO 1461: 2022 or EN ISO 10684:2004 + AC:2009 Strength class 8 according to EN ISO 898-2:2012
Washer	2a	PPM® ** L	Steel S355J2 according to EN 10025:2004 According to EN 10025:2004
	2b	PPM® ** L-HDG	Steel S355J2 according to EN 10025:2004, hot dip galvanized according to EN ISO 1461:2022 or EN ISO 10684:2004 + AC:2009 According to EN 10025:2004

Peikko PPM® L Anchor Bolts

**Product description
Materials**

Annex A3

Specifications of intended use

Anchorage subject to:

- Static and quasi-static tension, shear or combination of tension and shear.

Base materials:

- Reinforced, compacted normal weight concrete without fibres according to EN 206:2013+A2:2021.
- Strength classes C20/25 to C90/105 according to EN 206:2013+A2:2021.
- Cracked or uncracked concrete.

Intended use and environmental conditions:

- Anchor bars made of ribbed reinforcing steel, central threaded bar made of weldable, high strength steel, washer and hexagonal nut are made of steel:
Anchor bolts for use in structures subject to dry internal conditions.
- Anchor bars made of ribbed reinforcing steel, central threaded bar made of weldable, high strength steel, washer and hexagonal nut are made of hot dip galvanised steel according to EN ISO 1461:2022 or EN ISO 10684:2004 + AC:2009 with at least 50 µm thickness:
Anchor bolts for use in structures subject to internal conditions with usual humidity (exceptional permanently damp conditions and applications under water).
- Anchor bars made of ribbed reinforcing steel, central threaded bar made of weldable, high strength steel, washer and hexagonal nut are made of steel with concrete cover according to EN 1992-1-1:2004 + AC:2010+A1:2014: Anchor bolts for use in structures subject to appropriate exposition relating to the concrete cover

Design:

- Anchor bolts are designed under the responsibility of an engineer experienced in anchorages and concrete work.
- Verifiable calculation notes and drawings are prepared taking account of the loads to be anchored. The position of the anchor bars are indicated on the design drawings (e.g. position of the anchor bars relative to the reinforcement or to supports).
- For static and quasi-static loading the anchor bolts are designed in accordance with EN 1992-4:2018.
- The occurring splitting forces are resisted by the reinforcement. The required cross section of the minimum reinforcement is determined according EN 1992-4:2018, section 7.2.1.7.

Peikko PPM® L Anchor Bolts

Intended use
Specifications

Annex B1

Installation:

Placing anchor bolts into concrete

- The installation of anchor bolts is carried out by appropriately qualified personnel under the supervision of the person responsible for the technical matters on site.
- Use of the product only as supplied by the manufacturer.
- Installation in accordance with the manufacturers product installation instructions given in Annex B3.
- The anchor bolts are fixed to the formwork, reinforcement or auxiliary construction such that no movement of the product will occur during the time of laying the reinforcement and of placing and compacting the concrete.
- The concrete under the anchor bar head is properly compacted.
- The max. installation torque according to table 3 may not be exceeded.

Table 3: Installation parameters of PPM® L Anchor bolts

PPM® ...			30 L	36 L	39 L	45 L	52 L	60 L
Effective embedment depth	h_{ef}	[mm]	522	568	692	777	905	1055
Minimum spacing	s_{min}	[mm]	130	160	180	200	280	280
Minimum edge distance	c_{min}	[mm]	120	140	150	160	180	180
Protrusion height / thread length above concrete member	h_b	[mm]	135	160	175	190	220	260
Min. thickness of concrete member	h_{min}	[mm]	$h_{ef} + t_h + c_{nom}^{1)}$					
Max. installation torque General installation, case (a)	T_{inst}	[Nm]	200	300	400	600	900	1200
Max. installation torque Steel to steel contact, case (b)	T_{inst}	[Nm]	700	1200	1600	2600	4000	6300

1) Required concrete cover according to EN 1992-1-1:2004 +AC:2010+A1:2014

Peikko PPM® L Anchor Bolts

**Intended use
Installation parameters**

Annex B2

Installation instruction:

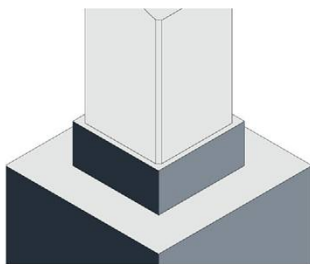
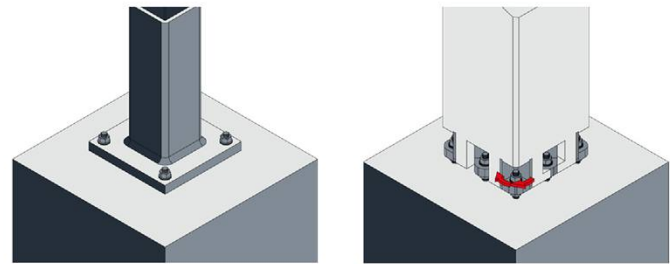
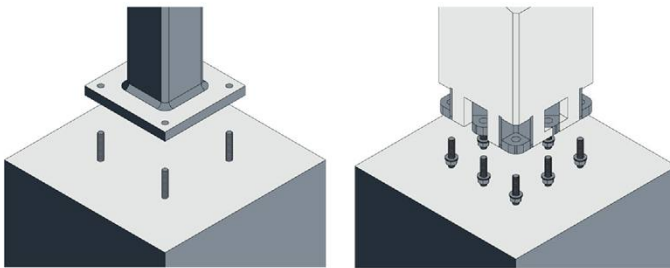
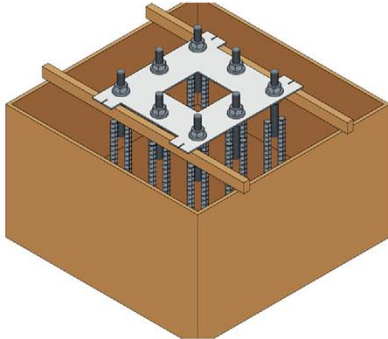

- Install the anchor bolts to the formwork by using a Peikko® installation template according design drawings to ensure the correct position, size and protrusion height (h_b) of the anchor bolts.
- Pay attention to a strong fixing of the anchor bolts to avoid moving during pouring.
- Compact concrete properly around and under the anchor bar head.
- After hardening of the concrete the installation template can be removed.
- For the installation of a steel column according to figure 1 (general installation) all nuts are removed.
- For the installation of a precast concrete column or steel column according to figure 2 (steel to steel contact) the lower levelling nuts are adjusted to the correct level.
- The connection is fixed by tightening the upper nuts.
- The installation torque T_{inst} acc. to Annex B2 may not be exceeded.
- The joint between the base structure and the column must be filled properly with non-shrinking mortar.

Peikko PPM® L Anchor Bolts

Intended use
Manufacturers product installation instructions (MPII)

Annex B3

Table 4: Characteristic resistances of PPM® L Anchor bolts under tension load

PPM® ...			30 L	36 L	39 L	45 L	52 L	60 L
Steel failure								
Characteristic resistance	$N_{Rk,s}$	[kN]	448,8	653,6	780,8	1044,8	1406,4	1769,3
Partial factor	$\gamma_{Ms}^{1)}$	[-]	1,5					1,4
Concrete pull-out failure								
Characteristic resistance in uncracked concrete C20/25	$N_{Rk,p}$	[kN]	792	1132	1188	1583	2557	2557
Characteristic resistance in cracked concrete C20/25	$N_{Rk,p}$	[kN]	566	809	848	1131	1827	1827
Increase factor for higher concrete grades for $N_{Rk,p}$ $N_{Rk,p} = N_{Rk,p(C20/25)} \cdot \psi_c$	ψ_c	C25/30	1,25					
		C30/37	1,50					
		C35/45	1,75					
		C40/50	2,00					
		C45/55	2,25					
Partial factor	$\gamma_{Mp}^{1)}$	[-]	1,5					1,5
Concrete cone failure								
Effective embedment depth	h_{ef}	[mm]	522	568	692	777	905	1055
Factor for the influence of the load transfer mechanism	$k_{ucr,N}$	[-]	12,7					
	$k_{cr,N}$	[-]	8,9					
Characteristic spacing	$s_{cr,N} = s_{cr,sp}$	[mm]	3 h_{ef}					
Characteristic edge distance	$c_{cr,N} = c_{cr,sp}$	[mm]	1,5 h_{ef}					
Partial factor	$\gamma_{Mp}^{1)}$	[-]	1,5					1,5
Concrete splitting								
A reinforcement has to be present to resist the splitting forces and limits the crack width to $w_k \leq 0,3$ mm. See EN 1992-4:2018, Section 7.2.1.7								

1) In absence of other national regulations

Peikko PPM® L Anchor Bolts

Performance
Characteristic resistances under tension load

Annex C1

Table 5: Characteristic resistances of PPM® L Anchor bolts under shear load

PPM® ...			30 L	36 L	39 L	45 L	52 L	60 L
Steel failure without lever arm								
Characteristic resistance	$V_{Rk,s}^0$	[kN]	224,4	326,8	390,4	522,4	703,2	944,8
Factor acc. EN 1992-4:2018, section 7.2.2.3.1	k_7	[-]	1,0					
Partial factor	$\gamma_{Ms}^{2)}$	[-]	1,25					
Steel failure with lever arm								
Characteristic resistance	$M_{Rk,s}^0$	[Nm]	1797	3160	4127	6391	9979	15544
Partial factor	$\gamma_{Ms}^{2)}$	[-]	1,25					
Concrete pry-out failure								
Factor acc. EN 1992-4:2018, section 7.2.2.4	$k_8^{1)}$	[-]	2,0					
Partial factor	$\gamma_{Mcp}^{2)}$	[-]	1,5					
Concrete edge failure								
Effective embedment depth under shear load	l_f	[mm]	240	288	312	360	416	480
Effective outer diameter	$d_{nom} = d$	[mm]	30	36	39	45	52	60
Partial factor	$\gamma_{Mc}^{2)}$	[-]	1,5					

1) If supplementary reinforcement is present, the factor k_8 has to be multiplied by 0,75

2) In absence of national regulations

Combined tension and shear load

Factor acc. EN 1992-4:2018, section 7.2.3	k_{11}	[-]	2/3					
--	----------	-----	-----	--	--	--	--	--

Table 6: Displacements of PPM® L Anchor bolts under tension load

PPM® ...			30 L	36 L	39 L	45 L	52 L	60 L
Tension load	N	[kN]	214	311	372	498	670	900
Short-term displacement	δ_{N0}	[mm]	0,5	0,5	0,6	0,6	0,5	0,8
Long-term displacement	$\delta_{N\infty}$	[mm]	1,0	1,0	1,2	1,2	1,0	1,6

Table 7: Displacements of PPM® L Anchor bolts under shear load

PPM® ...			30 L	36 L	39 L	45 L	52 L	60 L
Shear load	V	[kN]	107	156	186	249	335	450
Short-term displacement	δ_{V0}	[mm]	1,5	1,5	1,5	1,5	1,5	1,5
Long-term displacement	$\delta_{V\infty}$	[mm]	2,3	2,3	2,3	2,3	2,3	2,3

Peikko PPM® L Anchor Bolts

Performance
Characteristic resistances under shear load, combined tension and shear load
Displacements under tension and/ or shear load

Annex C2