

Approval body for construction products  
and types of construction

Bautechnisches Prüfamt

An institution established by the Federal and  
Laender Governments



## European Technical Assessment

**ETA-20/0670**  
**of 21 March 2024**

English translation prepared by DIBt - Original version in German language

### General Part

Technical Assessment Body issuing the  
European Technical Assessment:

Deutsches Institut für Bautechnik

Trade name of the construction product

Fasteners ejothem STR H A2, STR H E, STR H and  
EJOT HFS

Product family  
to which the construction product belongs

Fasteners for fixing external thermal insulation composite  
systems on timber constructions

Manufacturer

EJOT SE & Co. KG  
Astenbergstraße 21  
57319 Bad Berleburg  
DEUTSCHLAND

Manufacturing plant

EJOT Herstellwerke 1, 2, 3, 4 und 8

This European Technical Assessment  
contains

24 pages including 3 annexes which form an integral part  
of this assessment

This European Technical Assessment is  
issued in accordance with Regulation (EU)  
No 305/2011, on the basis of

333256-00-0603 – FASTENERS FOR FIXING  
EXTERNAL THERMAL INSULATION COMPOSITE  
SYSTEMS (ETICS) ON TIMBER CONSTRUCTIONS

This version replaces

ETA-20/0670 issued on 3 June 2022

The European Technical Assessment is issued by the Technical Assessment Body in its official language. Translations of this European Technical Assessment in other languages shall fully correspond to the original issued document and shall be identified as such.

Communication of this European Technical Assessment, including transmission by electronic means, shall be in full. However, partial reproduction may only be made with the written consent of the issuing Technical Assessment Body. Any partial reproduction shall be identified as such.

This European Technical Assessment may be withdrawn by the issuing Technical Assessment Body, in particular pursuant to information by the Commission in accordance with Article 25(3) of Regulation (EU) No 305/2011.

## Specific part

### 1 Technical description of the product

Fasteners ejotherm STR H A2, STR H E, STR H and EJOT HFS for fixing external thermal insulation composite systems (ETICS) on timber constructions (in the following referred to as fasteners) are screws made of austenitic or austenitic-ferritic stainless or carbon steel with a plastic plate for fixing external thermal insulation composite systems (ETICS).

Fasteners ejotherm STR H A2 and ejotherm STR H E are made of austenitic or austenitic-ferritic stainless steel and fasteners ejotherm STR H and EJOT HFS are made of electrogalvanized carbon steel. The outer thread diameter of the screws is  $d = 6$  mm.

The plastic plate is made of virgin material made of PA6 and fulfils the requirements of EAD 330196-01-0604 regarding durability against high alkalinity. The outer diameter of the plastic plate is 60 mm or 30 mm.

The length of the fastener is  $40 \text{ mm} \leq L_a \leq 600 \text{ mm}$ . Further dimensions are shown in Annex 1.

### 2 Specification of the intended use in accordance with the applicable European Assessment Document

The performances given in Section 3 are only valid if the fasteners ejotherm STR H A2, STR H E, STR H and EJOT HFS are used in compliance with the specifications and conditions given in Annex 3.

The verifications and assessment methods on which this European Technical Assessment is based lead to the assumption of a working life of the fasteners ejotherm STR H A2, STR H E, STR H and EJOT HFS of at least 25 years. The indications given on the working life cannot be interpreted as a guarantee given by the producer, but are to be regarded only as a means for choosing the right products in relation to the expected economically reasonable working life of the works.

### 3 Performance of the product and references to the methods used for its assessment

#### 3.1 Safety in case of fire (BWR 2)

Essential characteristic		Performance
Reaction to fire	Screw of the fastener	Class A1
	Plastic material of the anchor plate	Class E <sup>1</sup>
	Insulation plug made of polystyrene	Negligible <sup>2</sup>
	Insulation cap made of polystyrene	Class E <sup>3</sup>
	Insulation cap made of mineral wool	Class A1
<p>1 Valid for the plastic material as placed on the market, independent from the intended end-use as fastener for ETICS. Depending on the specific type of ETICS and its components surrounding the fastener, an influence of the plastic plates on the reaction to fire performance of the ETICS cannot completely be ruled out. A harmonized product specification for ETICS kits, in which the fasteners form part, may therefore prescribe, whether consideration and assessment of the reaction to fire performance of the fasteners is necessary within reaction to fire testing and classification of the kit or not.</p> <p>2 Due to its very small dimensions (see Annex 1.1 and 1.2) the insulation plug is considered as small component whose contribution to fire can be seen as negligible. Thus, testing and assessment of its reaction to fire performance is not needed.</p> <p>3 Valid for the polystyrene from which the insulation cap is made, independent from the intended end-use.</p>		

### 3.2 Safety and accessibility in use (BWR 4)

Essential characteristic	Performance
Dimensions	Annex 1
Bending angle of the screw	Annex 2.1
Characteristic tensile strength of the screw	Annex 2.1
Characteristic torsional strength	Annex 2.1
Mean insertion moment	Annex 2.1
Characteristic withdrawal capacity related to the minimum penetration length	Annex 2.2
Spacings, end and edge distances of the fasteners and minimum thickness of the timber material	Annex 2.2
Durability against corrosion of the screw	Annex 2.2
Characteristic load resistance of the anchor plate	Annex 2.3
Mean plate stiffness	Annex 2.3
High alkalinity of plastic plate	Annex 2.3

### 3.3 Energy economy and heat retention (BWR 6)

Essential characteristic	Performance
Point thermal transmittance of the screw with plate to fix the external thermal insulation	Annex 2.3

## 4 Assessment and verification of constancy of performance (AVCP) system applied, with reference to its legal base

In accordance with EAD 333256-00-0306 the applicable European legal act is: 97/176/EC, as amended by Commission Decision 2001/596/EC.

The system to be applied is: 3

## 5 Technical details necessary for the implementation of the AVCP system, as provided for in the applicable EAD

Technical details necessary for the implementation of the AVCP system are laid down in the control plan deposited with Deutsches Institut für Bautechnik.

Issued in Berlin on 21 March 2024 by Deutsches Institut für Bautechnik

Anja Dewitt  
Head of Section

*beglaubigt:*  
Blümel

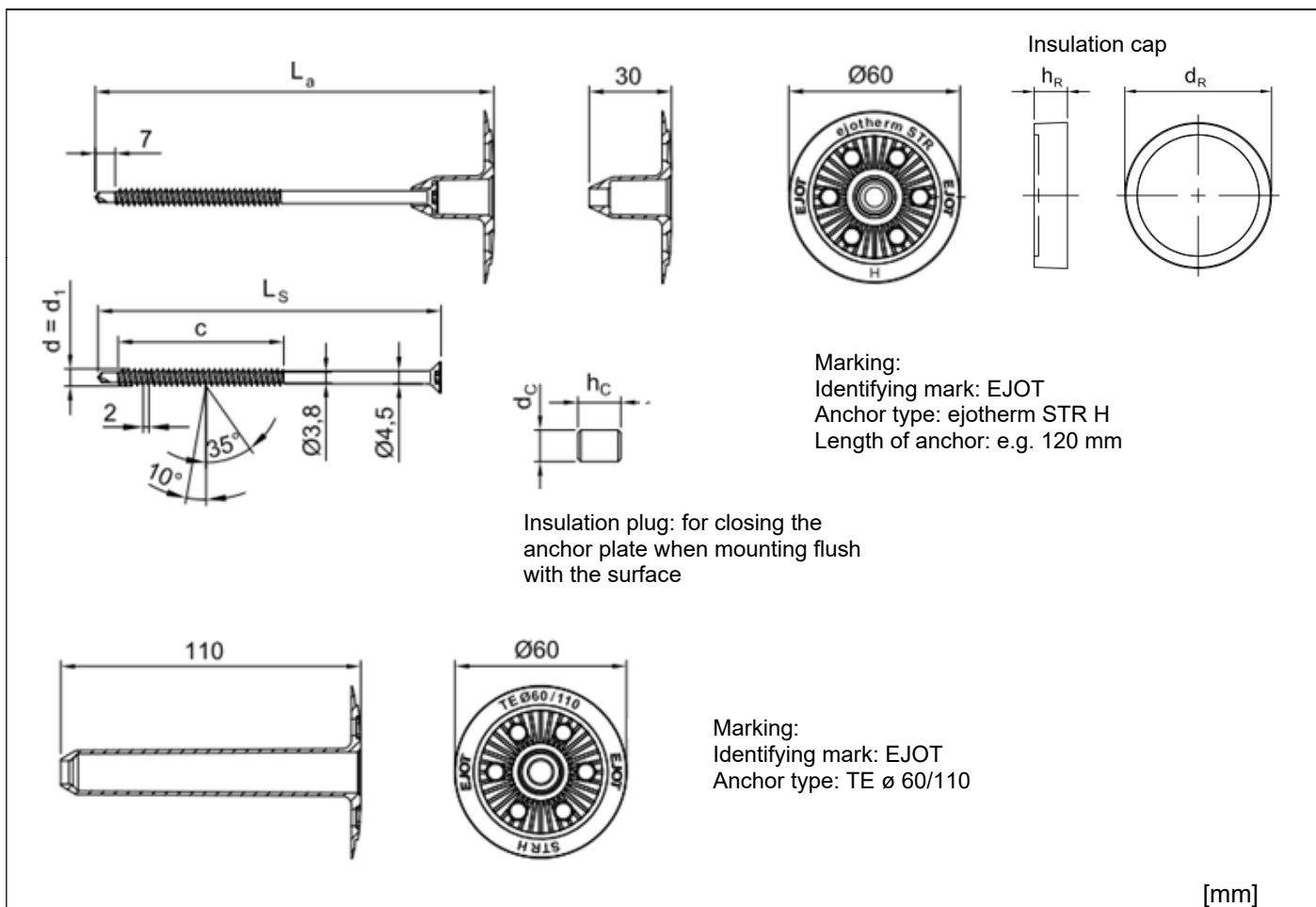

ejotherm STR H A2		anchor plate			special screw				insulation plug		insulation cap	
min La	max La	colour	plate diameter	plate length	d=d <sub>1</sub>	c	min L <sub>s</sub>	max L <sub>s</sub>	h <sub>c</sub>	d <sub>c</sub>	h <sub>R</sub>	d <sub>R</sub>
80	300	nature	60	30	6.0	60 <sup>1)</sup>	60	280	16	14	15	65
160	380	nature	60	110	6.0	60 <sup>1)</sup>	60	280	16	14	15	65

1) for screw length L<sub>a</sub> 60 mm: c = 38 mm

Fasteners ejotherm STR H A2, STR H E, STR H and EJOT HFS	Annex 1.1
Dimensions for the fastener ejotherm STR H A2	

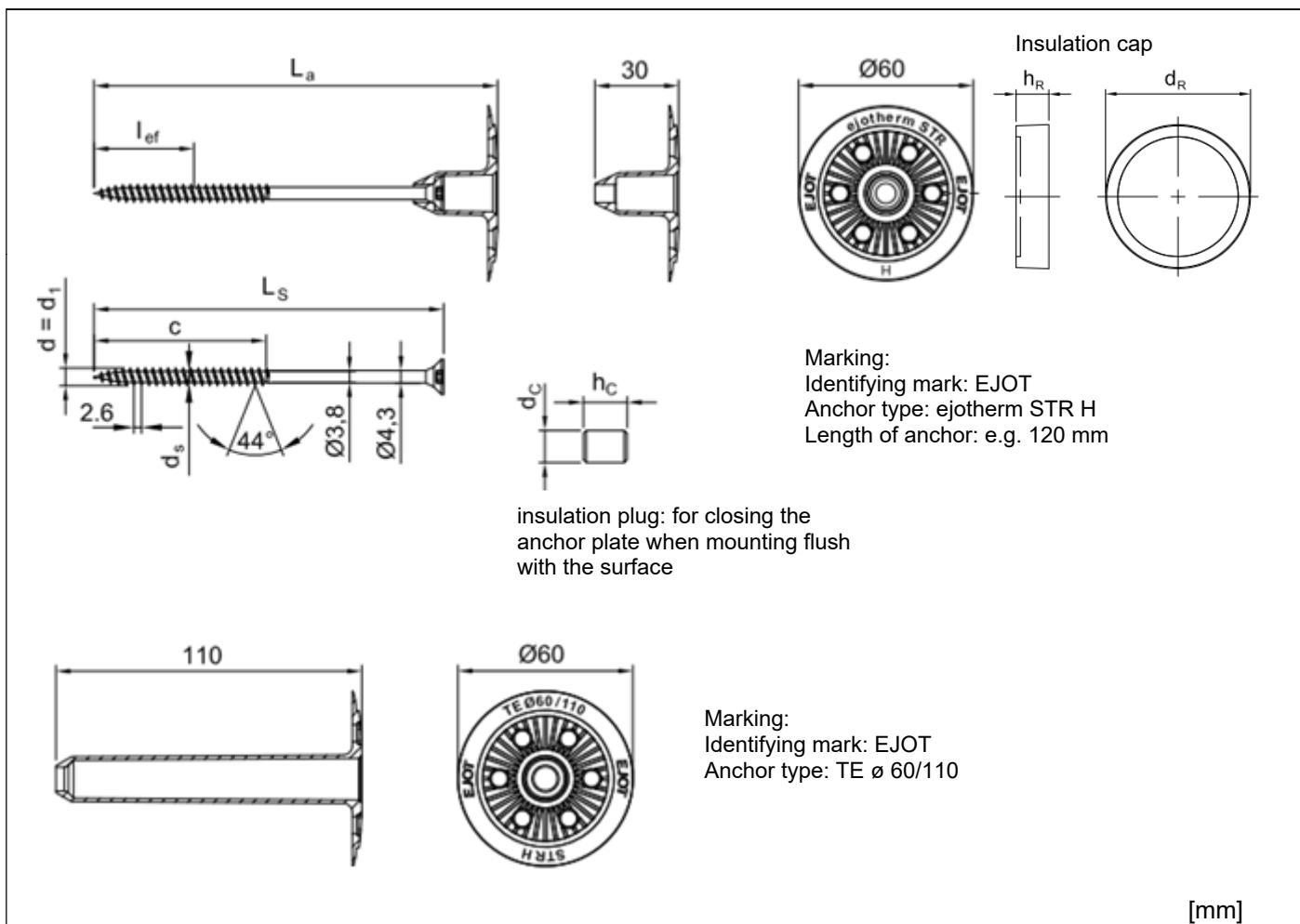

**Table A.1.2: Dimensions [mm]**

ejothem STR H / STR H E		anchor plate			special screw				insulation plug		insulation cap	
min L <sub>a</sub>	max L <sub>a</sub>	colour	plate diameter	plate length	d=d <sub>1</sub>	c	min L <sub>s</sub>	max L <sub>s</sub>	h <sub>c</sub>	d <sub>c</sub>	h <sub>R</sub>	d <sub>R</sub>
80	300	nature	60	30	6.0	60 <sup>1)</sup>	60	280	16	14	15	65
160	380	nature	60	110	6.0	60 <sup>1)</sup>	60	280	16	14	15	65

1) for screw length L<sub>a</sub> 60 mm: c = 50 mm

Fasteners ejothem STR H A2, STR H E, STR H and EJOT HFS

Dimensions for the fasteners ejothem STR H and ejothem STR H E

Annex 1.2

SBL 140 plus

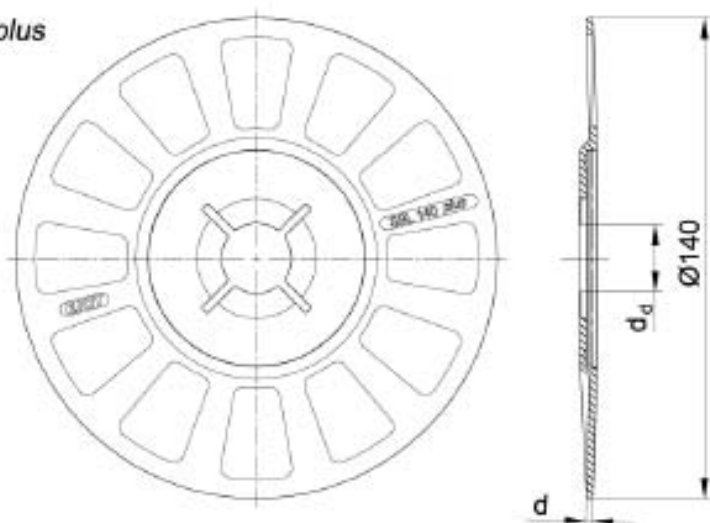

SBL 140 plus	
Farbe	nature
$d_d$ [mm]	20,0
$d$ [mm]	2,0

VT 90

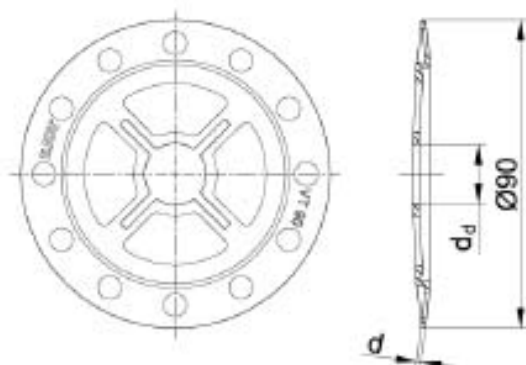

VT 90	
Farbe	nature
$d_d$ [mm]	18,5
$d$ [mm]	1,2

VT 2G

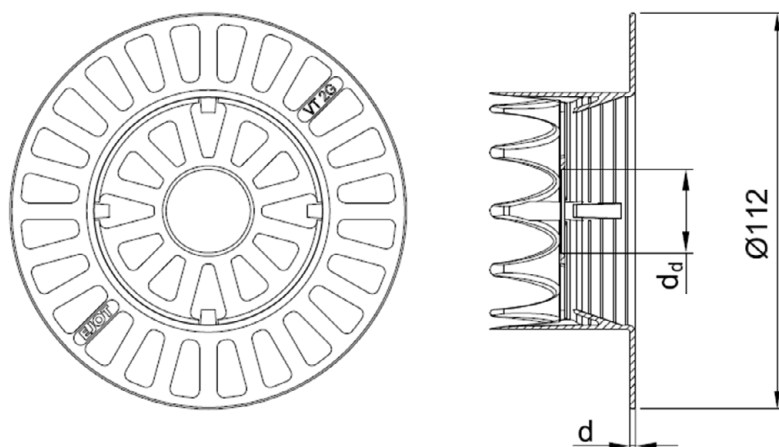

VT 2G	
Farbe	nature
$d_d$ [mm]	29,0
$d$ [mm]	1,5

[mm]

Fasteners ejotherm STR H A2, STR H E, STR H and EJOT HFS

Anchor plates in combination with fasteners ejotherm STR H A2 / STR H E / STR H

Annex 1.3

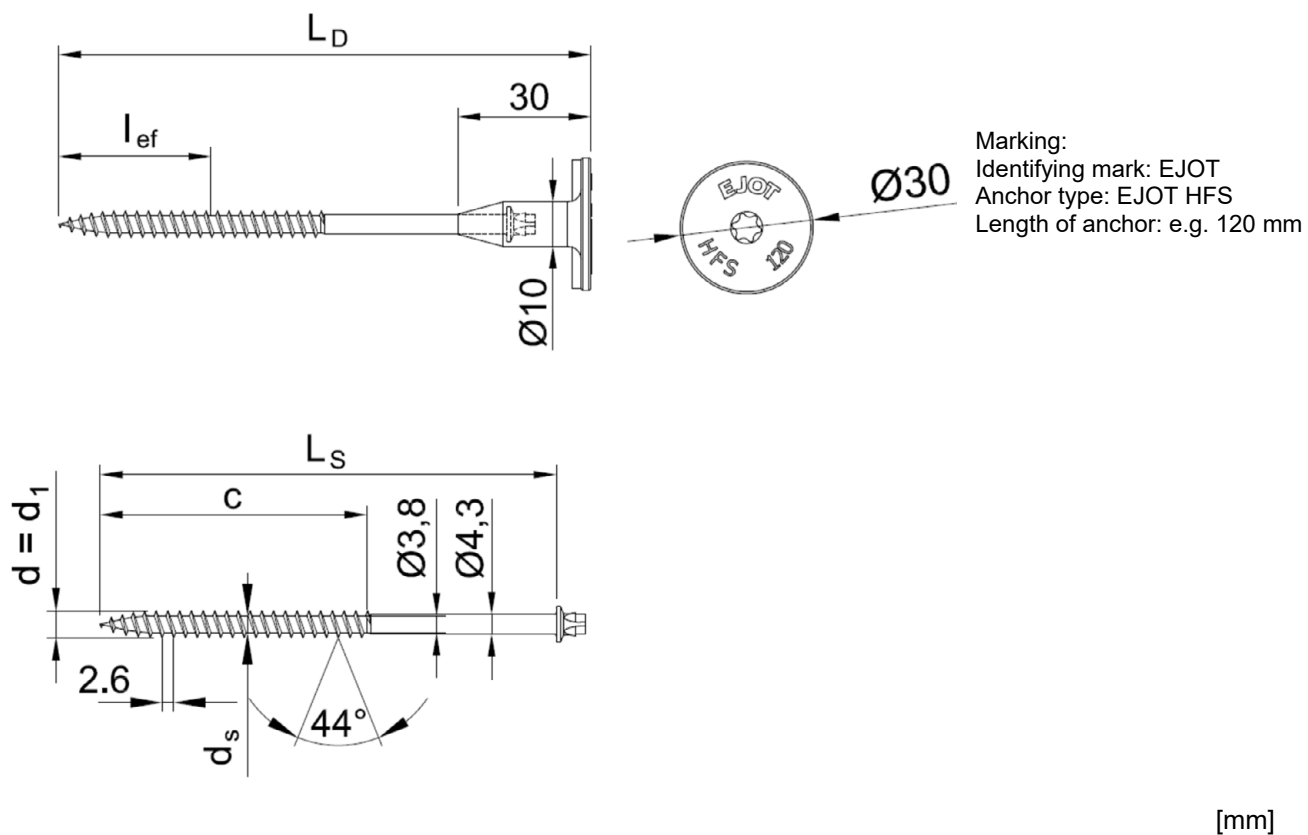

EJOT HFS		anchor plate		special screw			
min $L_D$	max $L_D$	colour	plate diameter	$d=d_1$	$c$	min $L_s$	max $L_s$
80	260	nature	30	6.0	60 <sup>1)</sup>	61	241

1) for screw length  $L_D$  80 mm:  $c = 42$  mm

Fasteners ejotherm STR H A2, STR H E, STR H and EJOT HFS

Dimensions for the fastener EJOT HFS

Annex 1.4



Table A.1.4: Materials	
Name	Materials
Anchor plate	Polyamide PA 6,GF50 Colour: nature
Insulation cap	Polystyrene PS 20 or mineral wool
Insulation plug	Polystyrene PS 30
Specific screw	Case hardening steel in accordance with EN 10263-3; zinc plated $\geq 5 \mu\text{m}$ in accordance with EN ISO 4042 blue passivated
	Stainless steel in accordance with EN ISO 3506-1 with the material number 1.4301

Table A.1.5: Anchor plate, diameter and materials				
anchor plate	$\varnothing D$ [mm]	$\varnothing d_d$ [mm]	d [mm]	materials
VT 90	90	18.5	1.2	PA 6
SBL 140 plus	140	20.0	2.0	PA 6,GF50
VT 2G	112	29.0	1.5	PA 6,GF50

Fasteners ejotherm STR H A2, STR H E, STR H and EJOT HFS	Annex 1.5
Materials	

## ANNEX 2 – Essential characteristics

### A.2.1 Safety and accessibility in use

The ETA includes the fastener resistance against axially loads resulting from wind only.

Table A.2.1 Essential characteristics of the fasteners ejotherm STR H A2, STR H E, STR H and EJOT HFS

Dimensions	See Annex 1		
Bending angle of the screw $\alpha$	$\geq 45/d^{0.7} + 20$		
Characteristic tensile strength of the screw $f_{tens,k}$ [kN]	STR H A2	STR H E	STR H and EJOT HFS
	9.1	8.6	11.0
Characteristic torsional strength $f_{tor,k}$ [Nm]	STR H A2	STR H E	STR H and EJOT HFS
	7.3	8.3	9.0
Mean insertion moment $R_{tor,mean}$	Ratio of characteristic torsional strength and mean insertion moment: $f_{tor,k} / R_{tor,mean} \geq 1.5$		
	Timber product and wood-based panel in accordance with Annex A.3.2		Maximum penetration length of the fastener EJOT HFS [mm]
	Solid wood, glued laminated timber, glued solid timber, cross laminated timber		60
	OSB, particleboards		40
	Cement-bonded particleboards Eternit Duripanel A2 <sup>b</sup>		16

Fasteners ejotherm STR H A2, STR H E, STR H and EJOT HFS	Annex 2.1
Essential characteristics	

Characteristic withdrawal capacity related to the minimum penetration length $F_{ax,90,k}$	Timber product, wood-based panel or gypsum fibreboard in accordance with Annex A.3.2	Minimum penetration length of the threaded part of the screw in the timber product, wood-based panel or gypsum fibreboard $l_{ef}$ [mm]	$F_{ax,90,k}$  [N]
	Solid timber, glued laminated timber, glued solid timber, cross laminated timber	35	1570
	Boards made of solid timber	24 <sup>a</sup>	
	OSB	12 <sup>a</sup>	760
	Particleboards	16 <sup>a</sup>	1080
	Cement-bonded particleboards Eternit Duripanel A2 <sup>b</sup>	16 <sup>a</sup>	1250
	Gypsum fibreboards in accordance with ETA-03/0050	15 <sup>a</sup>	970
	Gypsum fibreboards in accordance with ETA-08/0147	12,5 <sup>a</sup>	610
		15 <sup>a</sup>	750
		18 <sup>a</sup>	870
<sup>a</sup> The screw tip protrudes at least 10 mm outside the boards or panels. <sup>b</sup> On substructures made of cement-bonded particleboards only fastener ejothem STR H A2 are used.			
Minimum spacings, end and edge distances	<p>For ejothem STR H A2, STR H E, STR H und EJOT HFS the minimum spacings, end and edge distances for timber products, wood-based panels and gypsum fibreboards are given in EN 1995-1-1, clause 8.3.1.2 and Table 8.2 as for nails in non-predrilled holes. Here, the outer thread diameter <math>d</math> given in Annex 1.1, 1.2 and 1.4 shall be considered. The minimum distances from loaded or unloaded ends parallel to the grain shall be at least <math>15 \cdot d</math>.</p> <p>For minimum spacings, end and edge distances in timber members in accordance with European Technical Assessments the provisions in the corresponding European Technical Assessment apply.</p>		
Durability against corrosion of the screw	<p>Screws made of carbon steel are electrogalvanized. The thickness of the zinc coating of the screws is at least 5 <math>\mu</math>m.</p> <p>Steel no. 1.4301 is used for screws made from stainless steel.</p>		

Fasteners ejothem STR H A2, STR H E, STR H and EJOT HFS	Annex 2.2
Essential characteristics	

Plastic plate		
Fastener type	ejotherm STR H A2, STR H E, STR H	EJOT HFS
Material	ISO 16396 <sup>1</sup> -PA 6,GF50	
Plate diameter [mm]	60	30
Characteristic load resistance of the anchor plate [kN]	2.6	1.35 <sup>2</sup>
Mean plate stiffness [kN/mm]	2.7	1.15 <sup>2</sup>
High alkalinity of plastic plate	The limits for susceptibility to environmental stress cracking in accordance with EAD 330196-01-0604, clause 2.2.2.12 are met.	
The essential characteristics for the plastic plates for ejotherm STR H A2, STR H E and STR H were determined after accelerated conditioning in accordance with EN ISO 1110 <sup>3</sup> (70 °C and 62 % relative humidity), for the plastic plate for EJOT HFS in accordance with EAD 333256-00-0306, 2.2.5 (equilibrium water content at 23 °C and 50 % relative humidity).		

### A.2.2 Point thermal transmittance of a screw with plate to fix the external thermal insulation

The given point thermal transmittances of the fastener ejotherm STR H A2, STR H E and STR H are valid in conjunction with thermal insulations with a design value of the thermal conductivity of  $\lambda_B \geq 0.035$  W/(mK).

Table A.2.2 Point thermal transmittance  $\chi$  of the fasteners ejotherm STR H A2, STR H E and STR H

Fastener type	Type of mounting / insulation thickness	Point thermal transmittance $\chi$ [W/K]
ejotherm STR H A2 ejotherm STR H E	Flush mounting and an insulation thickness of $40 \text{ mm} \leq d \leq 260 \text{ mm}$	0.001
	Deep mounting and an insulation thickness of $60 \text{ mm} \leq d \leq 280 \text{ mm}$	0.001
ejotherm STR H	Flush mounting and an insulation thickness of $40 \text{ mm} \leq d \leq 260 \text{ mm}$	0.002
	Deep mounting and an insulation thickness of $60 \text{ mm} \leq d \leq 280 \text{ mm}$	0.001

The given point thermal transmittance of the fastener EJOT HFS is valid in conjunction with thermal insulations with a design value of the thermal conductivity of  $\lambda_B \geq 0,038$  W/(mK).

Table A.2.3 Point thermal transmittance  $\chi$  of the fastener EJOT HFS

Fastener type	Type of mounting / insulation thickness	Point thermal transmittance $\chi$ [W/K]
EJOT HFS	Flush mounting and an insulation thickness of $40 \text{ mm} \leq d \leq 260 \text{ mm}$	0.002

- <sup>1</sup> EN ISO 16396-1:2015                      Plastics – Polyamide (PA) moulding and extrusion materials – Part 1: Designation system, marking of products and basis for specifications
- <sup>2</sup> In accordance with EAD 333256-00-0306, 2.2.5 the inner diameter of the support ring D was 20 mm in the test for the plastic plate of the fastener EJOT HFS.
- <sup>3</sup> EN ISO 1110:2019                      Plastics – Polyamides – Accelerated conditioning of test specimens

Fasteners ejotherm STR H A2, STR H E, STR H and EJOT HFS	Annex 2.3
Essential characteristics	

## ANNEX 3 – Specifications of intended use

### A.3.1 General

Use of the fasteners only for:

- non-fatigue static and quasi-static loads,
- multiple fixings. Hence in the case of excessive slip or failure of a fixing point the load is transmitted to adjacent fixing points.

### A.3.2 Base materials

Fasteners ejothem STR H A2, STR H E, STR H and EJOT HFS are used for fixing ETICS on the following timber constructions made of spruce, fir or pine:

- Solid timber in accordance with EN 14081-1<sup>4</sup> at least of strength class C24 in accordance with EN 338<sup>5</sup>,
- Glued laminated timber in accordance with EN 14080<sup>6</sup>,
- Glued solid timber in accordance with EN 14080 with laminations of at least strength class C24 in accordance with EN 14081-1,
- Cross laminated timber in accordance with European Technical Assessments. Layers in that fasteners are screwed in are at least of strength class C24 in accordance with EN 388. The width of the gap between laminations in a layer is maximum 3.5 mm.

Fasteners ejothem STR H A2, STR H E, STR H and EJOT HFS are intended to be used on substructures made of the following wood-based panels in accordance with EN 13986<sup>7</sup> that are suitable for internal (or protected external) use as structural components in humid conditions as specified in EN 13986:

- Oriented strand boards, OSB/3 or OSB/4, in accordance with EN 300<sup>8</sup> and EN 13986 with a minimum density of 550 kg/m<sup>3</sup>,
- Particleboards in accordance with EN 312<sup>9</sup> and EN 13986 with a minimum density of 650 kg/m<sup>3</sup>.

Fasteners ejothem STR H E and STR H are also intended to be used on substructures made of gypsum fibreboards in accordance with EN 15283-2<sup>10</sup> with a minimum density of 1150 kg/m<sup>3</sup> (in accordance with ETA-03/0050) or 1200 kg/m<sup>3</sup> (in accordance with ETA-08/0147).

Fastener ejothem STR H A2 is also intended to be used on substructures made of

- Cement-bonded particleboards Eternit Duripanel A2 in accordance with EN 634-2<sup>11</sup> and EN 13986 with a minimum density of 1300 kg/m<sup>3</sup>.

In the case that the fasteners are driven into solid timber boards, wood-based panels or gypsum fibreboards the screws are fully screwed through boards or panels. The screw tip protrudes at least 10 mm outside the boards or panels (see Annexes 3.3 to 3.9).

Fasteners ejothem STR H and EJOT HFS are only used for fixing ETICS made of factory-made wood fibre (WF) products in accordance with EN 13171<sup>12</sup>.

Fasteners ejothem STR H A2, STR H E, STR H can be additionally combined with plastic plates VT 90, VT 2G and SBL 140 plus in accordance with Annexes 3.4, 3.5, 3.7 and 3.8.

4	EN 14081-1:2005+A1:2011	Timber structures – Strength graded structural timber with rectangular cross section – Part 1: General requirements
5	EN 338:2016	Structural timber – Strength classes
6	EN 14080:2013	Timber structures – Glued laminated timber and glued solid timber – Requirements
7	EN 13986:2004+A1:2015	Wood-based panels for use in construction – Characteristics, evaluation of conformity and marking
8	EN 300:2006	Oriented strand boards (OSB) – Definition, classification and specifications
9	EN 312:2010	Particleboards – Specifications
10	EN 15283-2:2008+A1:2009	Gypsum boards with fibrous reinforcement – Definitions, requirements and test methods – Part 2: Gypsum fibreboards
11	EN 634-2:2007	Cement-bonded particleboards – Specifications – Part 2: Requirements for OPC bonded particleboards for use in dry, humid and external conditions
12	EN 13171:2012+A1:2015	Thermal insulating products for buildings – Factory made wood fibre (WF) products – Specification

Fasteners ejothem STR H A2, STR H E, STR H and EJOT HFS	Annex 3.1
Specifications of intended use	

**A.3.3 Use Conditions (environmental conditions)**

The corrosion protection of the fasteners ejothem STR H A2, STR H E, STR H and EJOT HFS is specified in Annex 2.2.

**A.3.4 Installation provisions**

EN 1995-1-1<sup>13</sup> applies for the installation.

The fasteners are driven into the timber products, wood-based panels or gypsum fibreboards through the thermal insulation material without pre-drilling in one sequence.

The minimum penetration length of the threaded part of the screws in structural timber products is  $l_{ef} \geq 6 \cdot d$ .

The penetration length of the threaded part of the screws in wood-based panels or gypsum fibreboards is  $l_{ef} \geq 12$  mm and in solid timber boards  $l_{ef} \geq 24$  mm, whereby the screw tip protrudes at least 10 mm outside the boards or panels.

For driving the fasteners into the substructures appropriate tools in accordance with the manufacturer's instructions are used. The manufacturer's instructions in accordance with Annexes 3.10 to 3.12 should be considered.

The plastic plates are not longer than 6 weeks exposed to UV-radiation during installation, in end use they are protected by the rendering.

Countersunk installation of the fasteners ejothem STR H A2, STR H E, STR H and EJOT HFS is feasible. The provisions given in the technical specification of the respective ETICS should be considered.

<sup>13</sup> EN 1995-1-1: 2004/AC:2006 +A1:2008+A2:2014 Eurocode 5: Design of timber structures – Part 1-1: General – Common rules and rules for buildings

Fasteners ejothem STR H A2, STR H E, STR H and EJOT HFS	Annex 3.2
Use conditions and installation provisions	

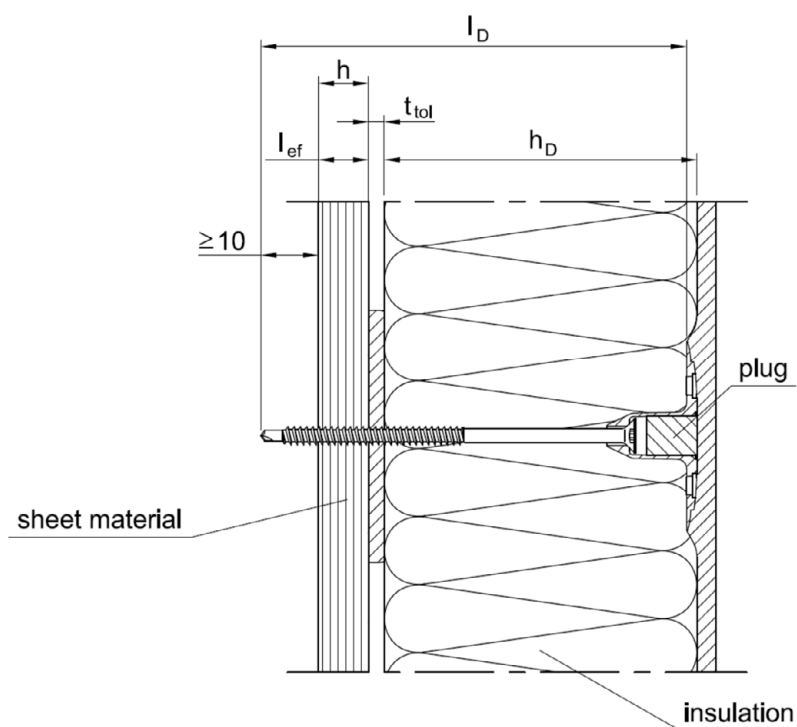
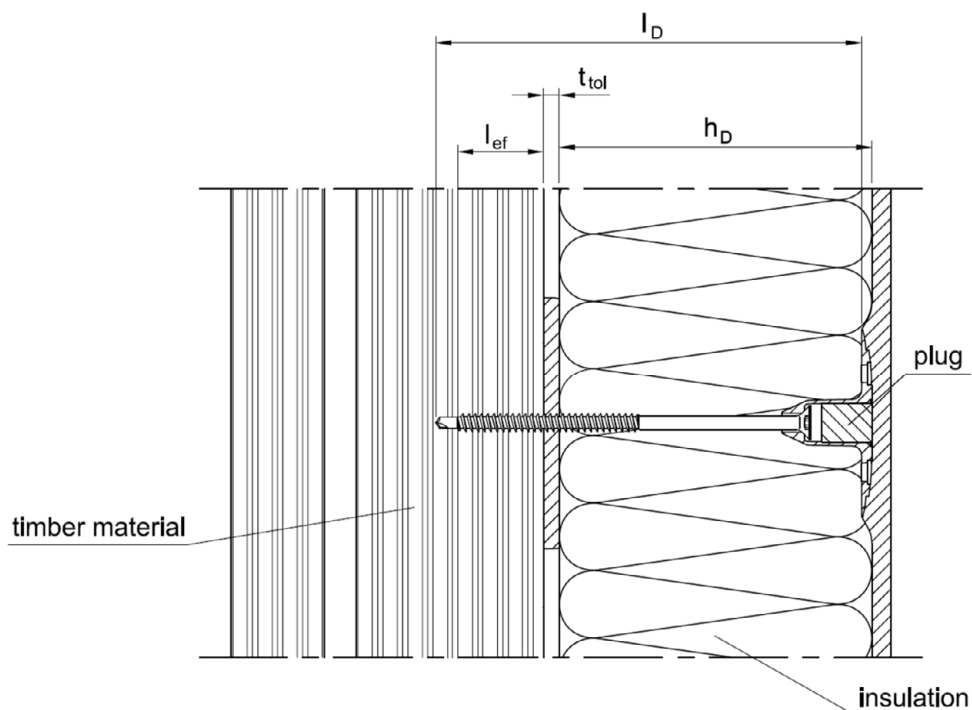

[mm]

Fasteners ejotherm STR H A2, STR H E, STR H and EJOT HFS	Annex 3.3
Installed condition ejotherm STR H A2, surface-flush installation	

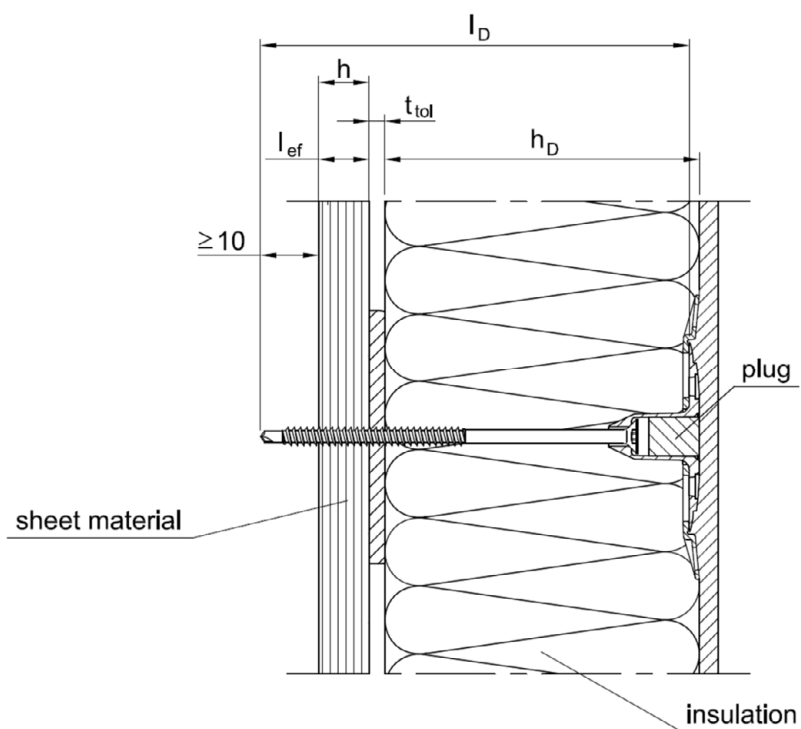
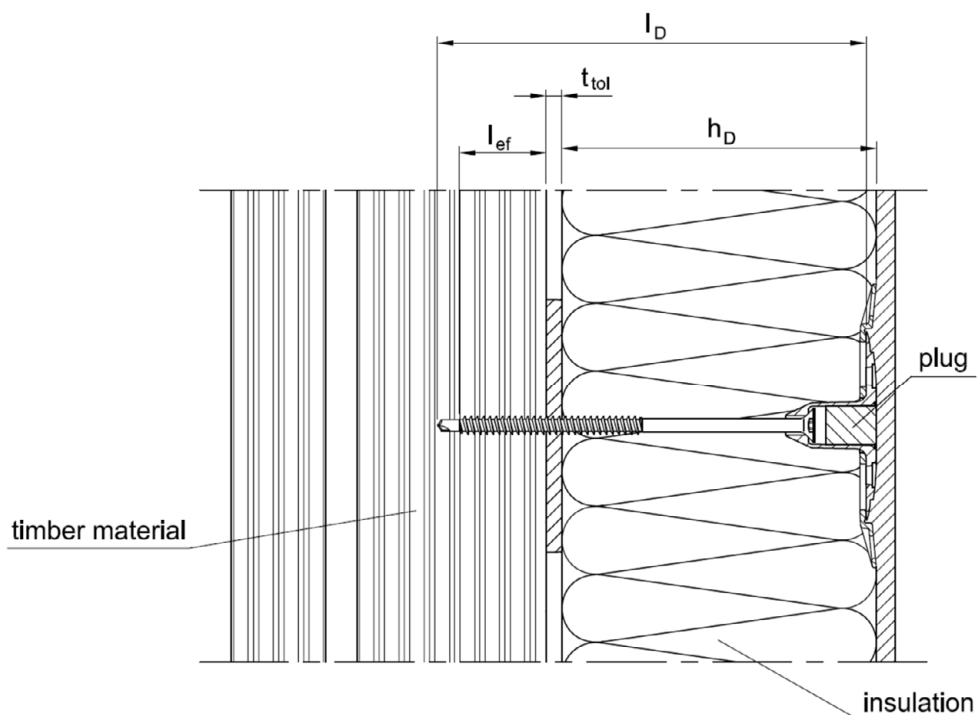

[mm]

Fasteners ejotherm STR H A2, STR H E, STR H and EJOT HFS	Annex 3.4
Installed condition ejotherm STR H A2 with anchor plate VT 90, surface-flush installation	



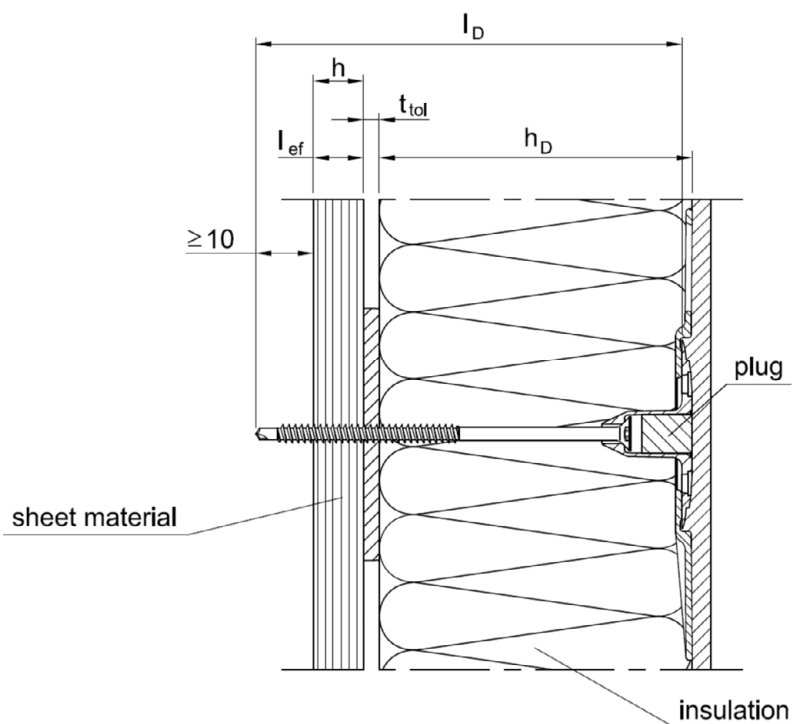
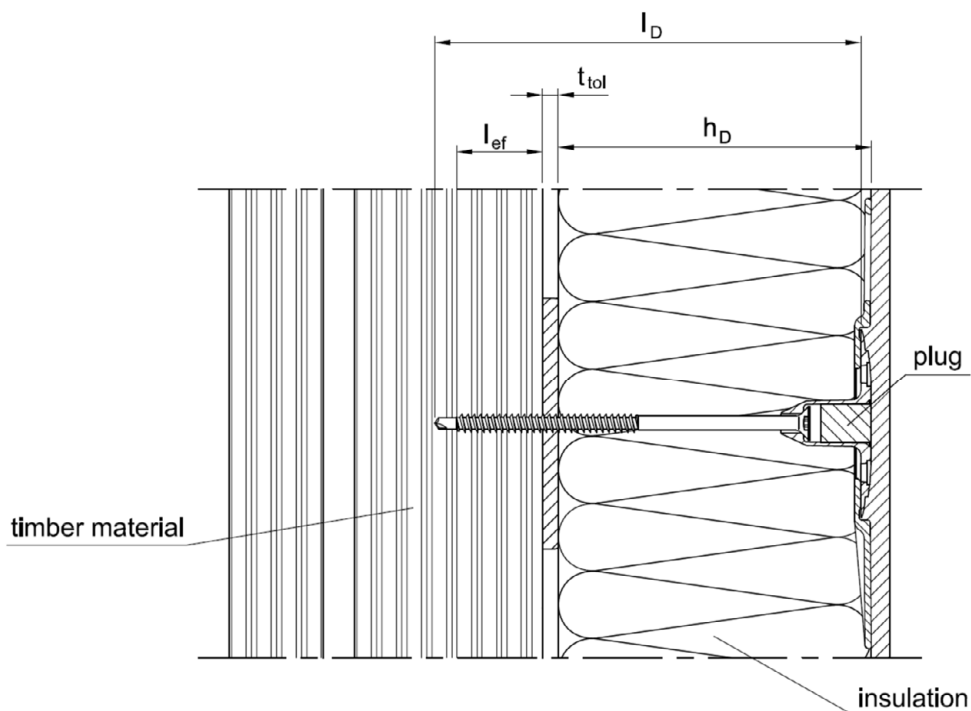

[mm]

Fasteners ejotherm STR H A2, STR H E, STR H and EJOT HFS	Annex 3.5
Installed condition ejotherm STR H A2 with anchor plate SBL 140 plus, surface-flush installation	

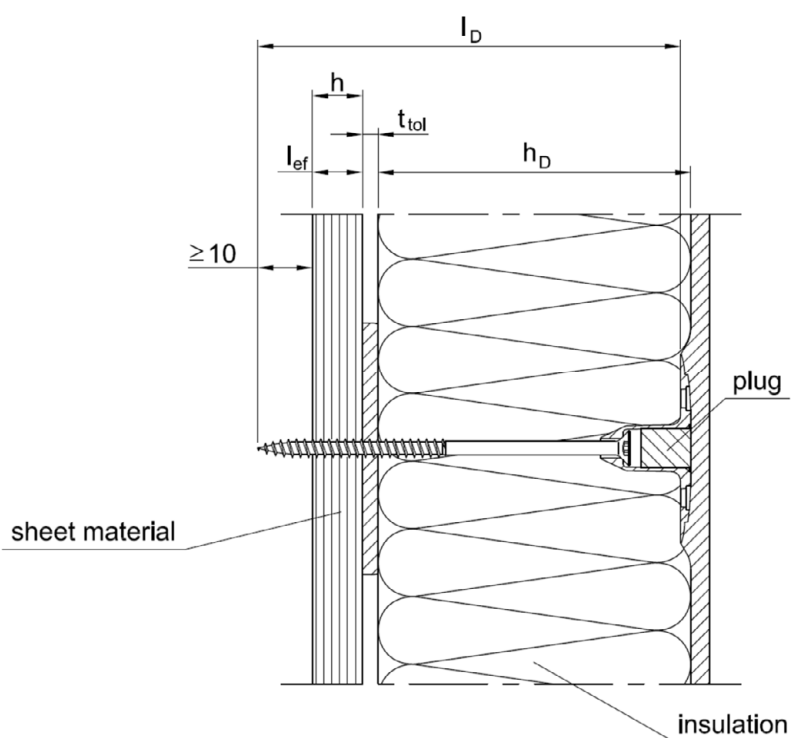
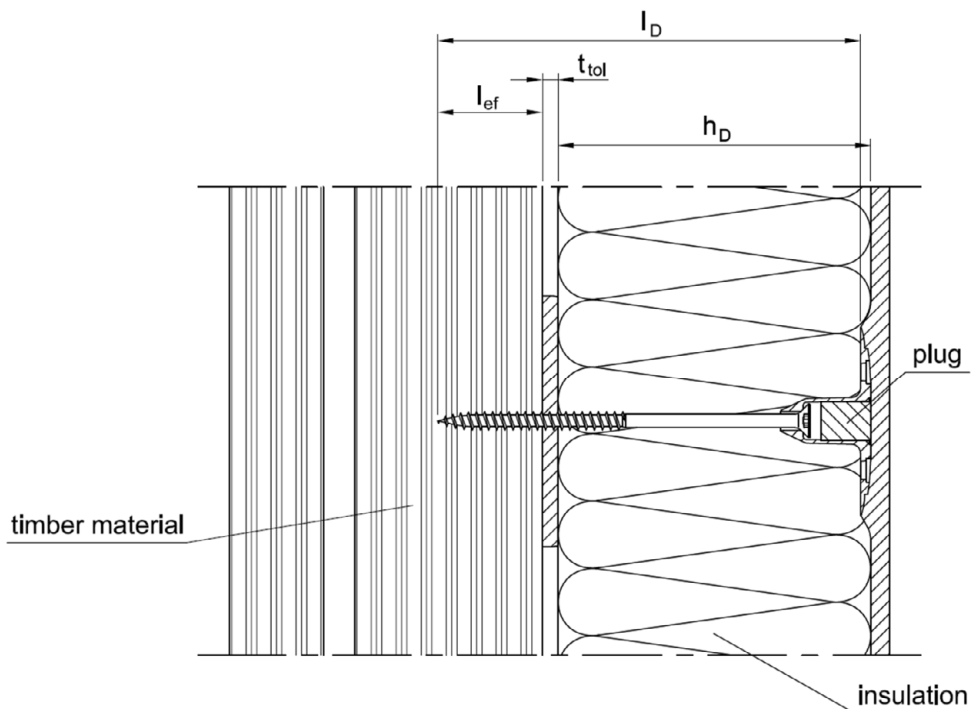

[mm]

Fasteners ejotherm STR H A2, STR H E, STR H and EJOT HFS	Annex 3.6
Installed condition ejotherm STR H and ejotherm STR H E, surface-flush installation	

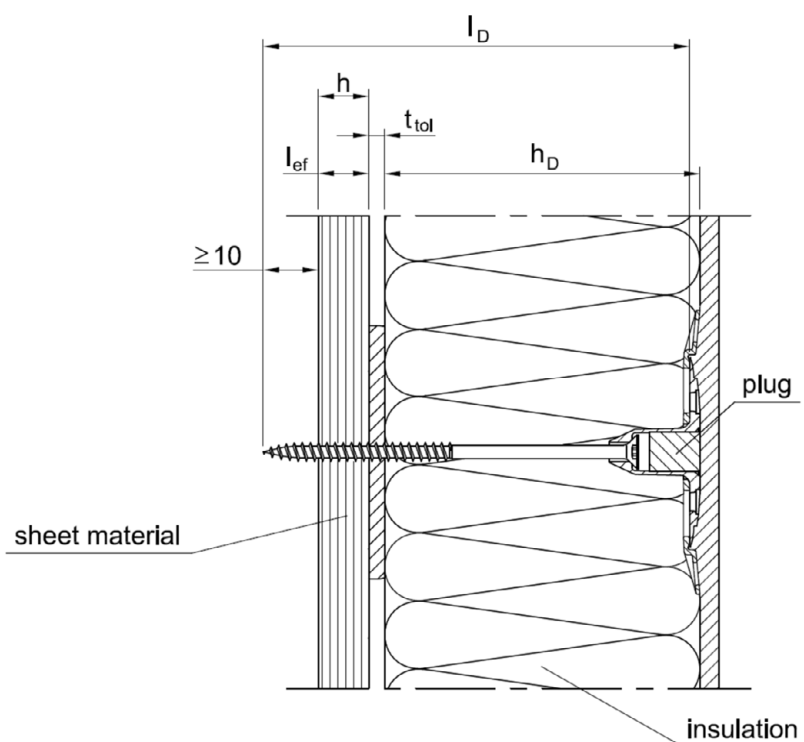
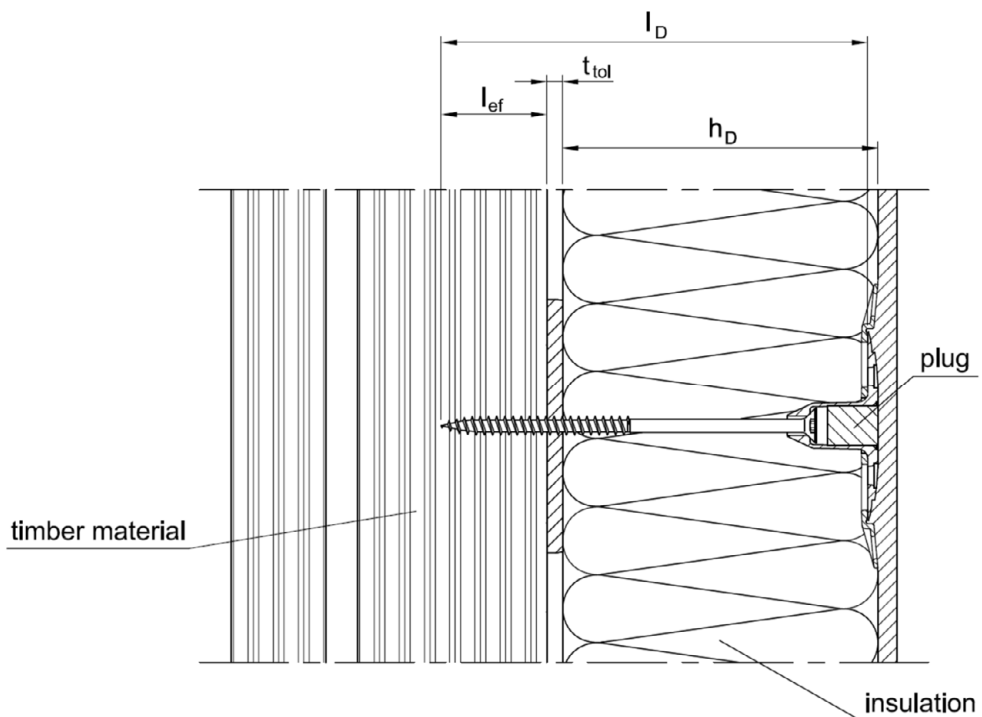

[mm]

Fasteners ejotherm STR H A2, STR H E, STR H and EJOT HFS	Annex 3.7
Installed condition ejotherm STR H and ejotherm STR H E with anchor plate VT 90, surface-flush installation	

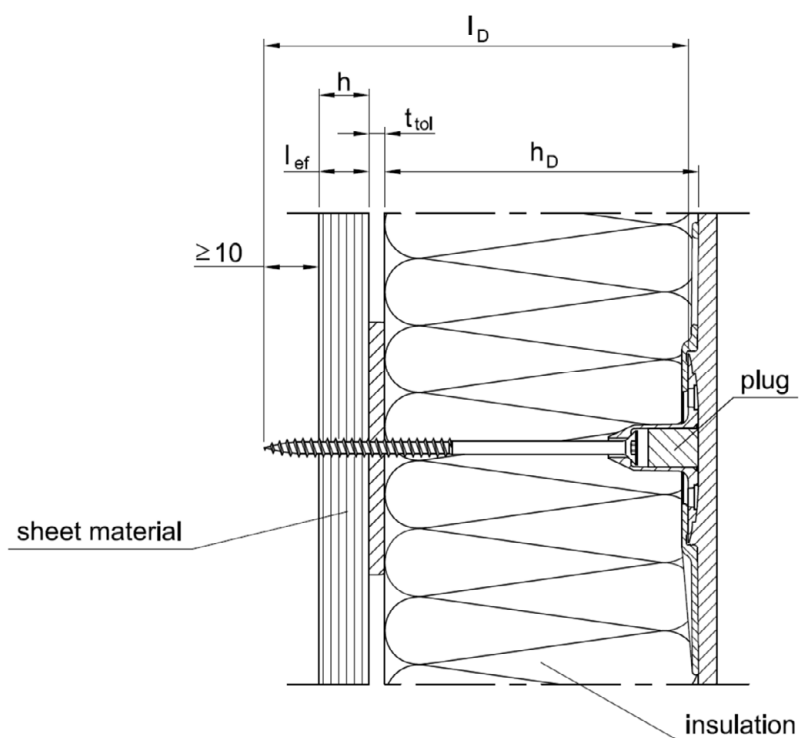
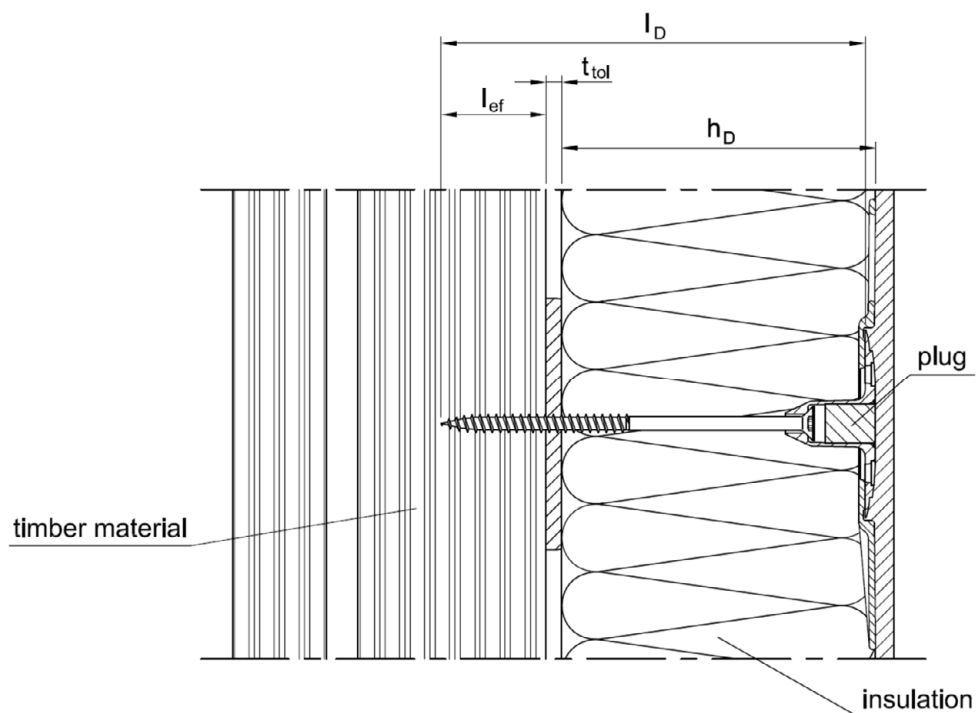

[mm]

Fasteners ejotherm STR H A2, STR H E, STR H and EJOT HFS	Annex 3.8
Installed condition ejotherm STR H and ejotherm STR H E with anchor plate SBL 140 plus, surface-flush installation	

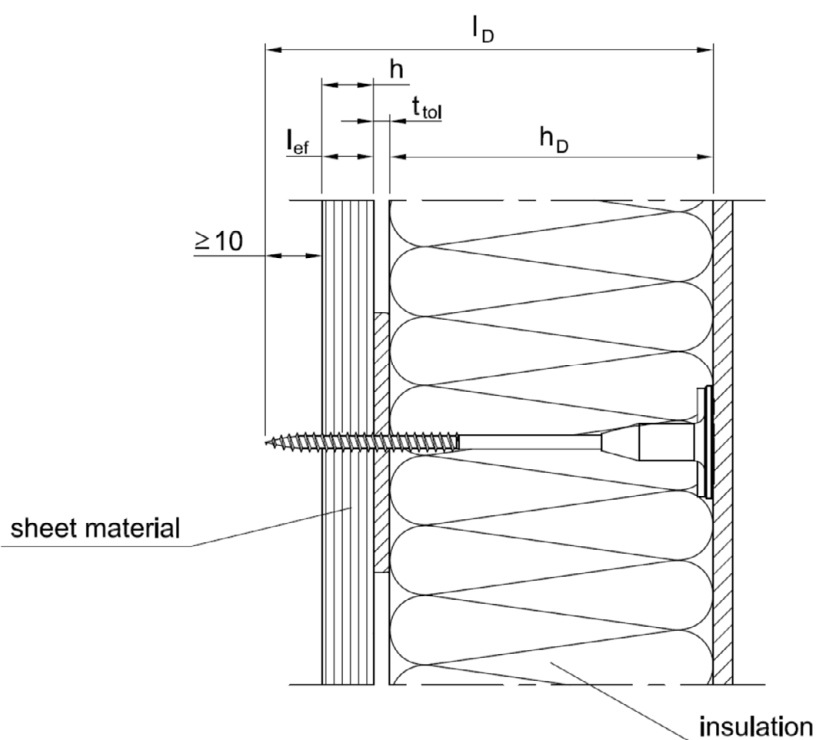
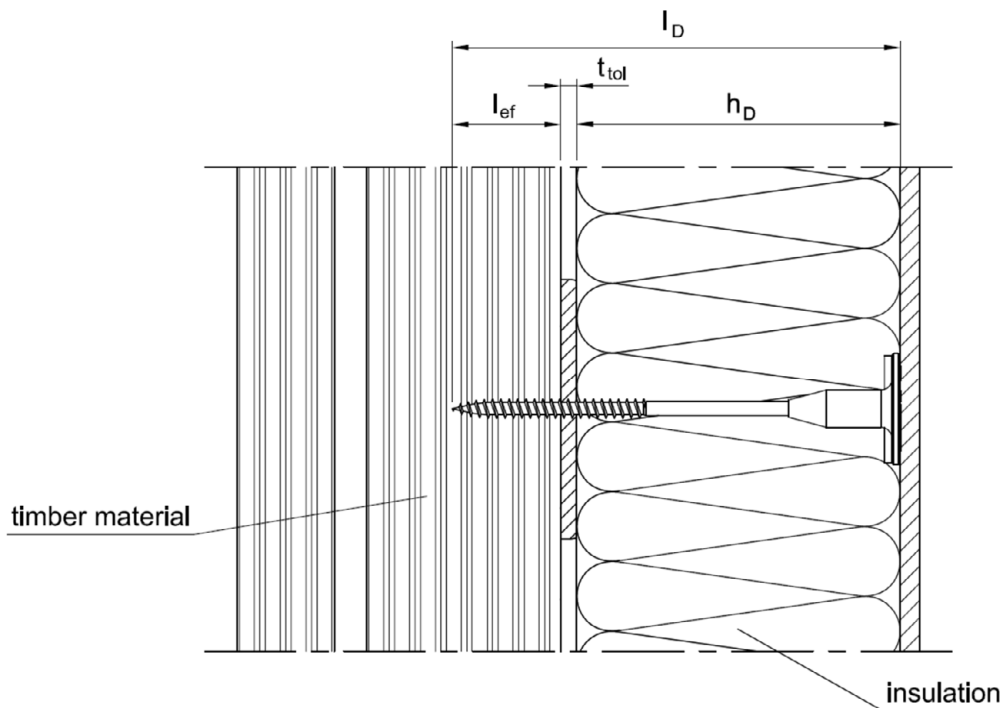

[mm]

Fasteners ejotherm STR H A2, STR H E, STR H and EJOT HFS	Annex 3.9
Installed condition EJOT HFS, surface-flush installation	

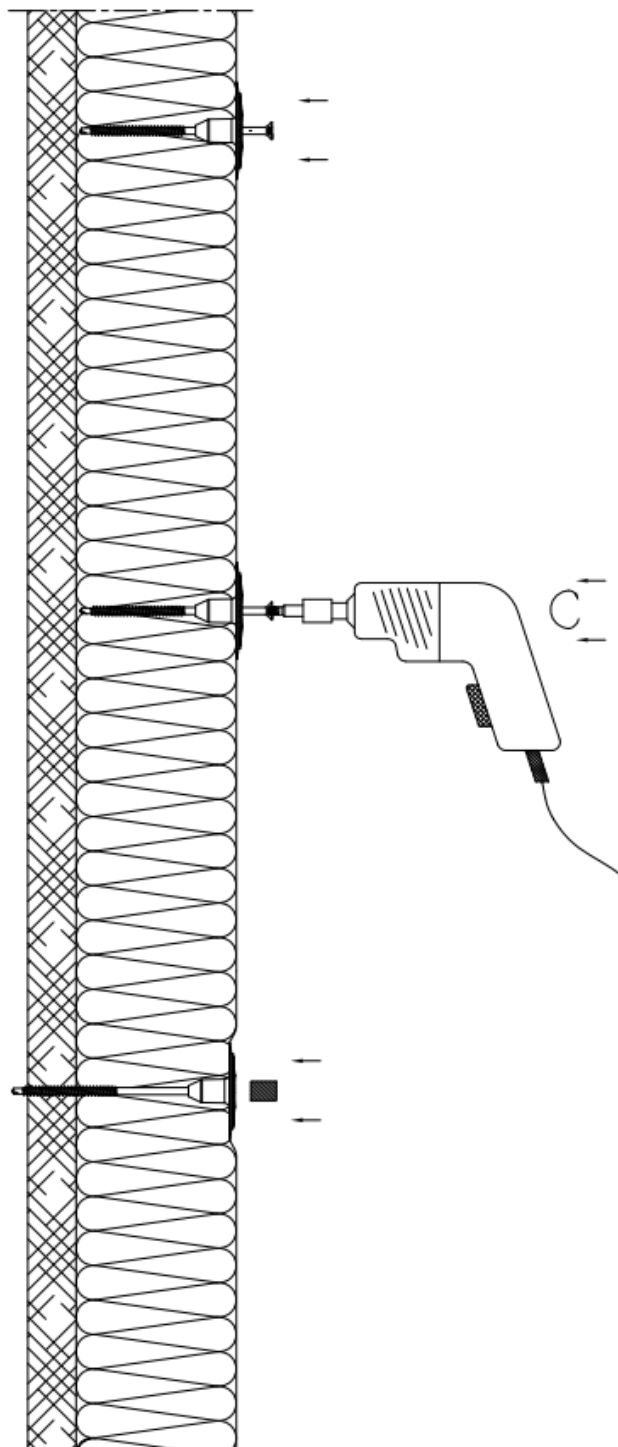

Push the anchor into the insulation material until the plate flushes with the insulation board surface.

Install the anchor screw until plate contact. The anchor plate should be inserted slightly into the insulation material.

Insert the EPS plug flush with the surface of the anchor plate.

Fasteners ejotherm STR H A2, STR H E, STR H and EJOT HFS	Annex 3.10
Installation instructions for ejotherm STR H A2, surface-flush installation	

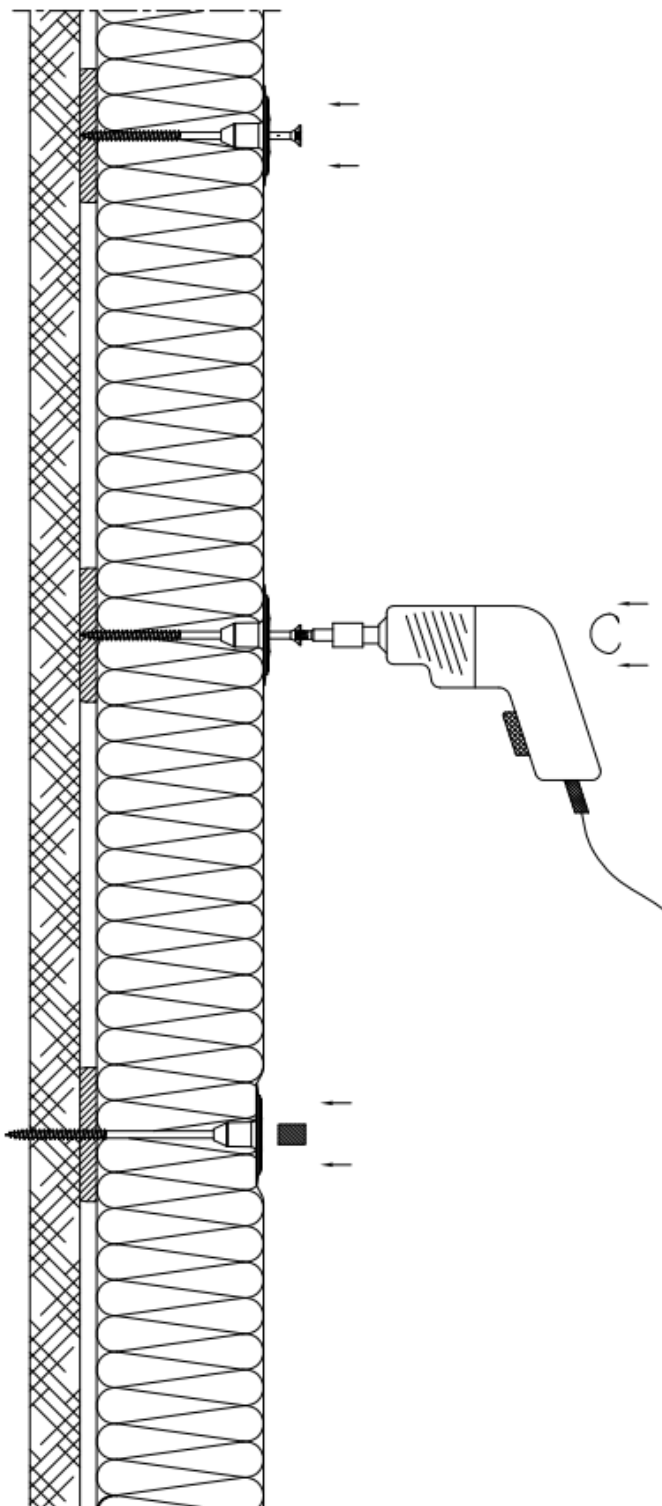

Push the anchor into the insulation material until the plate flushes with the insulation board surface.

Install the anchor screw until plate contact. The anchor plate should be inserted slightly into the insulation material.

Insert the EPS plug flush with the surface of the anchor plate.

Fasteners ejotherm STR H A2, STR H E, STR H and EJOT HFS	Annex 3.11
Installation instructions for ejotherm STR H and ejotherm STR H E, surface-flush installation	

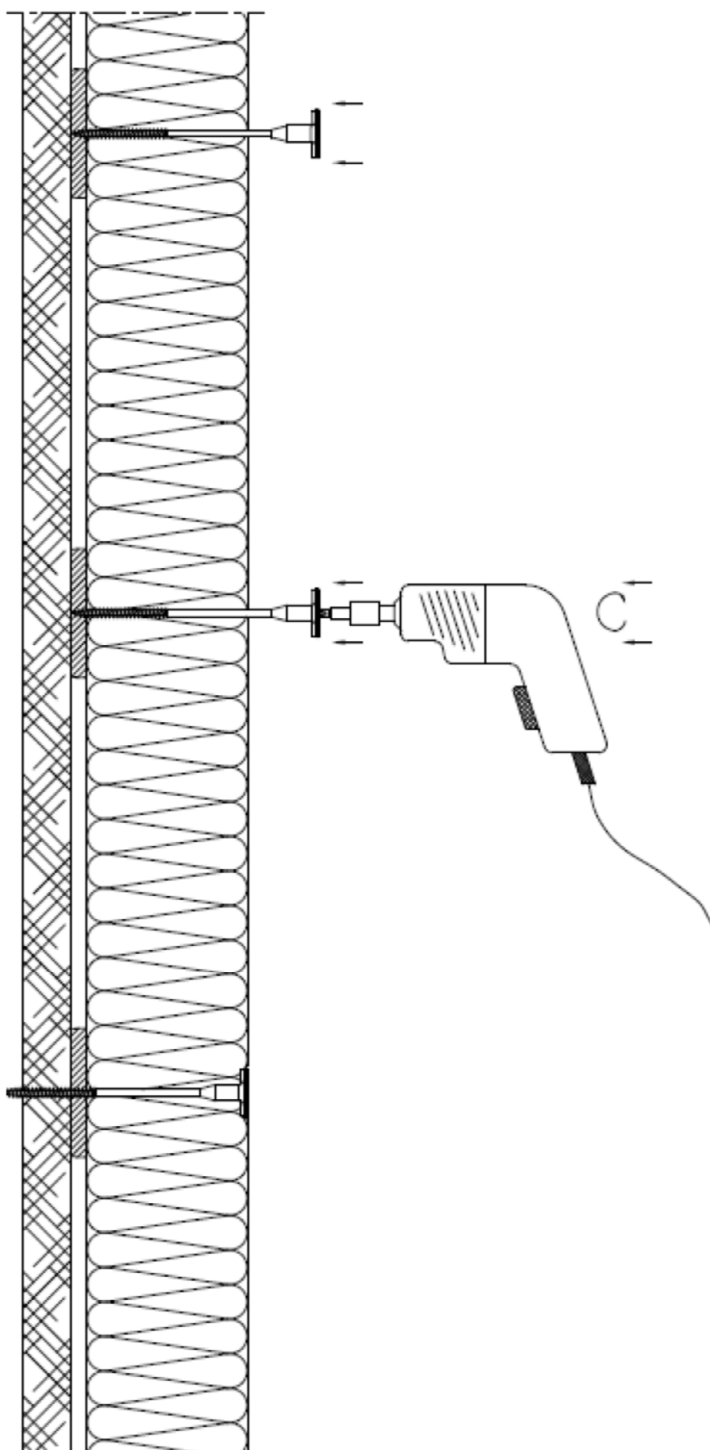

Push the anchor screw into the insulation material until the anchor screw touches the substructure.

Install the anchor screw into the substructure.

The anchor plate should be inserted slightly into the insulation material.

Fasteners ejotherm STR H A2, STR H E, STR H and EJOT HFS	Annex 3.12
Installation instructions for EJOT HFS, surface-flush installation	