

Public-law institution jointly founded by the federal states and the Federation

European Technical Assessment Body
for construction products



European Technical Assessment

ETA-24/0041
of 7 May 2024

English translation prepared by DIBt - Original version in German language

General Part

Technical Assessment Body issuing the European Technical Assessment:

Deutsches Institut für Bautechnik

Trade name of the construction product

SAFEX MULTI BD
SAFEX EASY BD
SAFEX OF BD
VARIANT BD
SAFEX LIGHT BD
SAFEX MULTI HD
VARIANT HD
VARIANT HD30

Product family
to which the construction product belongs

Anchor devices for fastening personal fall protection systems to concrete structures

Manufacturer

GRÜN GmbH
Spezialmaschinenfabrik
Siegener Straße 81-83
57234 Wilnsdorf - Niederdielfen
DEUTSCHLAND

Manufacturing plant

Plants of GRÜN GmbH

This European Technical Assessment contains

21 pages including 17 annexes which form an integral part of this assessment

This European Technical Assessment is issued in accordance with Regulation (EU) No 305/2011, on the basis of

EAD 331072-00-0601

The European Technical Assessment is issued by the Technical Assessment Body in its official language. Translations of this European Technical Assessment in other languages shall fully correspond to the original issued document and shall be identified as such.

Communication of this European Technical Assessment, including transmission by electronic means, shall be in full. However, partial reproduction may only be made with the written consent of the issuing Technical Assessment Body. Any partial reproduction shall be identified as such.

This European Technical Assessment may be withdrawn by the issuing Technical Assessment Body, in particular pursuant to information by the Commission in accordance with Article 25(3) of Regulation (EU) No 305/2011.

Specific part

1 Technical description of the product

The subject of this assessment are anchor points for protecting persons (operators) working at heights against a fall. The fall protection systems are made of stainless steel 1.4301 / 1.4307. It is fastened on reinforced concrete with minimum strength classes C20/25 according to EN 206¹. The fall protection systems are fastened to the concrete with the different fasteners which can be found in the following table 1 and the annexes.

This ETA includes the products listed in the following table 1:

Table 1: Products of this ETA

Annexes Nr.	Trade name (products of this ETA)	Fastener
2	SAFEX MULTI BD	EJOT BA-E Plus 10/10/- alternativ: Fischer FAZ II M10/10-A4
3	SAFEX EASY BD	Fischer FAZ II M16/25-A4
4	SAFEX OF BD	Injection mortar FIS-SB-390-S
5	VARIANT BD	EJOT BA-E Plus 12/10/- alternativ: Fischer FAZ II M12/10 K A4 MKT BZ plus M12-10/85 s A4
6	SAFEX LIGHT BD	EJOT Multifix SE100 Seismic Fischer Superbond FIS SB 390-S
7	SAFEX MULTI HD	Hollow-ceiling anchor FHY M10 A4
8	VARIANT HD	Hollow-ceiling anchor FHY M10 A4
9	VARIANT HD30	Hollow-ceiling anchor FHY M10 A4

The components and the system setup of the product are given in Annex (2-9).

2 Specification of the intended use in accordance with the applicable EAD 33-1072-01-0601

The fall protection systems listed in table 1 is used to protect operators working at height, by arresting them in a fall. The operators attach themselves to the eye using e.g. ropes and carabiners. In the case of a fall the fall protection systems listed in Table prevent the fall and resulting physical damage assuming the correct usage by the operator. The fall protection systems listed in table are designed for use in all areas of industry, construction and maintenance. The intended use of the fall protection systems listed in table 1 is the attachment to flat roofs or other flat surfaces made of concrete.

¹

EN 206:2013+A2:2021

Concrete - Specification, performance, production and conformity

The direction of load for the SAFEX und VARIANT protection system (In all variations) shall be parallel to the mounting level. Thus use at a (concrete-) wall is intended only when the direction of force still applies at a 90 ° angle to the fastening axis

The performances given in Section 3 are only valid if the products listed in table 1 are used in compliance with the specifications and conditions given in Annexes 2 - 9.

The verifications and assessment methods on which this European Technical Assessment is based lead to the assumption of a working life of the products listed in table 1 of at least 25 years. The indications given on the working life cannot be interpreted as a guarantee given by the producer, but are to be regarded only as a means for choosing the right products in relation to the expected economically reasonable working life of the works.

3 Performance of the product and references to the methods used for its assessment

3.1 Safety in case of fire (BWR 2)

Essential characteristic	Performance
Reaction to fire	Class A1

3.2 Safety and accessibility in use (BWR 4)

Essential characteristic	Performance
Static loading	Level (kN); see respective product in annexes
Dynamic loading	Level (No. of users); see respective product in annexes
Check of deformation capacity in case of constraining forces	see respective product in annexes
Durability	No performance assessed

4 Assessment and verification of constancy of performance (AVCP) system applied, with reference to its legal base

In accordance with EAD No. 331072-01-0601, the applicable European legal act is: Decision (EU) 2018/771.

The system to be applied is: 1+

5 Technical details necessary for the implementation of the AVCP system, as provided for in the applicable EAD

Technical details necessary for the implementation of the AVCP system are laid down in the control plan deposited with Deutsches Institut für Bautechnik.

Issued in Berlin on 7 May 2024 by Deutsches Institut für Bautechnik

Dr.-Ing. Ronald Schwuchow
Head of Section

beglaubigt:
Hahn

This ETA includes the product variants listed in Table 1:

Table 1: Product variants of the ETA

Annex	Trade name (Product in this ETA)	Fastener	Substructure
2	SAFEX MULTI BD	EJOT BA-E Plus 10/10/- ^b Fischer FAZ II 10/10 A4 ^d	Reinforced concrete C20/25 to C50/60 ^a (cracked and uncracked)
3	SAFEX EASY BD	Fischer FAZ II 16/25 A4 ^d	
4	SAFEX OF BD	Fischer FIS SB 390 S ^c	
5	VARIANT BD	EJOT BA-E Plus 12/10/- ^b Fischer FAZ II 12/10 K A4 ^d MKT BZ plus M12-10/85 s A4 ^e	
6	SAFEX LIGHT BD	Fischer FIS SB 390 S ^c ; EJOT MULTIFIX SE1000 SEISMIC ^g	
7	SAFEX MULTI HD	FHY M10 A4 ^f	Prestressed concrete - hollow core slabs min. C45/55 ^a
8	VARIANT HD	FHY M10 A4 ^f	
9	VARIANT HD30	FHY M10 A4 ^f	

Annexes 2 to 9 show the components and the system structure of the products.

Design values of the action

$$F_{Ed} = F_{Ek} \cdot \gamma_F$$

The recommended partial safety factor γ_F is 1,5

The recommended partial safety factor is used to determine the corresponding design actions, provided that no partial safety factor is given in national regulations or national annexes to EN 1990.

That leads to the following values:

Example:

For one user $F_{Ed} = F_{Ek} \cdot \gamma_F = 6 \text{ kN} \cdot 1,5 = 9 \text{ kN}$

For two users $F_{Ed} = F_{Ek} \cdot \gamma_F = (6 + 1) \text{ kN} \cdot 1,5 = 10,5 \text{ kN}$

For three users $F_{Ed} = F_{Ek} \cdot \gamma_F = (6 + 2) \text{ kN} \cdot 1,5 = 12 \text{ kN}$

For four users $F_{Ed} = F_{Ek} \cdot \gamma_F = (6 + 3) \text{ kN} \cdot 1,5 = 13,5 \text{ kN}$

^a	EN 206:2013+A1:2016	Concrete – Specifications, performance, production and conformity
^b	ETA-18/0219	EJOT Through bolt BA-E Plus
^c	ETA-12/0258	fischer Superbond; DIBt 22.07.2019
^d	ETA-05/0069	fischer Bolt anchor FAZ II, DIBt 05.08.2016
^e	ETA 99/0010	Through bolt BZ plus und BZ-IG
^f	Z-21.1.1711	fischer Hollow-ceiling anchor FHY
^g	ETA-20/1280	Injection system EJOT MULTIFIX SE1000 SEISMIC for concrete

Fall protection SAFEX and VARIANT

Overview and Design Values

Annex 1

Table 2: Substructure Reinforced concrete C20/25 to C50/60 (cracked and uncracked)

Anchor device	Bar height [mm]	Fastener	Edge distance C_{min} [mm]	Minimum substructure thickness h_{min} [mm]
SAFEX MULTI BD	300 - 1000	EJOT BA-E Plus 10/10/- or Fischer FAZ II 10/10 A4	200	100

All components of the anchorage system can be used in weathered outdoor areas.
The concrete substructure must be pre-drilled with a borehole diameter of 10mm and a borehole depth of ≥ 75 mm must be pre-drilled.

Design resistance

$$F_{R,d} = \frac{F_{R,k}}{\gamma_M} = \frac{27,7 \text{ kN}}{1.5} = 18,5 \text{ kN}$$

The recommended partial safety factor γ_F is 1,5, provided that no partial safety factor is specified in national regulations or national annexes to Eurocode 2.

Dynamic load capacity

Maximum 4 users

Deformation capacity

≤ 10 mm at 0,70kN for a free length ≤ 300 mm over roof surface.

Fall protection SAFEX and VARIANT

GRÜN SAFEX MULTI BD for concrete C20/25 to C50/60 (cracked and uncracked)

Annex 2.1

all dimensions in [mm]

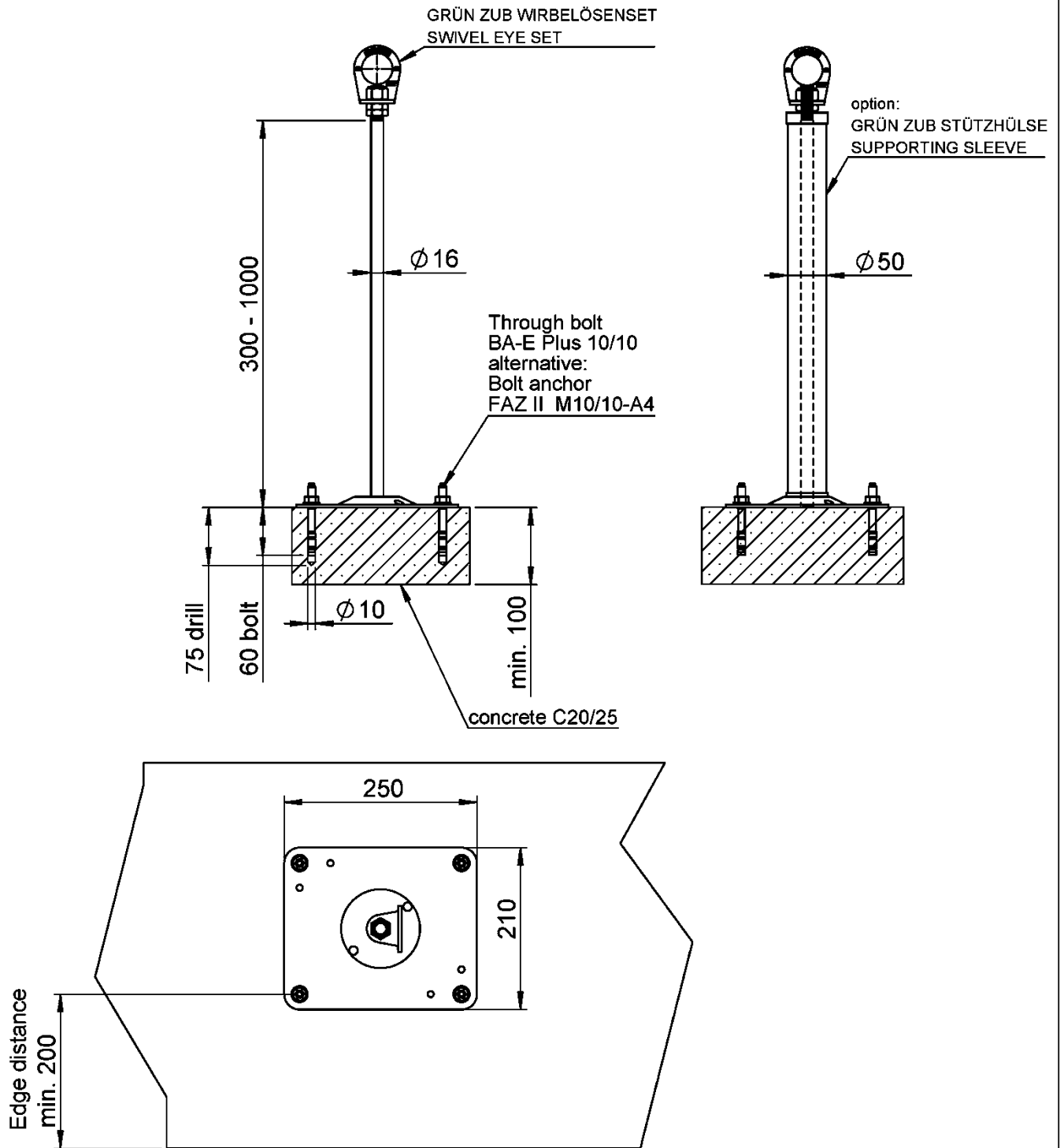

Designation in GREENLINE lifeline system
GRÜN SYS SAFEX MULTI BD Z

Fall Protection SAFEX and VARIANT

GRÜN SAFEX MULTI BD for concrete C20/25 till C50/60 (cracked and non-cracked)

Annex 2.2

Table 3: Substructure Reinforced concrete C20/25 to C50/60 (cracked and uncracked)

Anchor device	Bar height [mm]	Fastener	Edge distance C_{min} [mm]	Minimum substructure thickness h_{min} [mm]
SAFEX EASY BD	200 - 1000	Fischer FAZ II 16/25 A4	300	140

All components of the anchorage system can be used in weathered outdoor areas.
The concrete substructure must be pre-drilled with a borehole diameter of 16mm and a borehole depth of ≥ 125 mm must be pre-drilled.

Design resistance

$$F_{R,d} = \frac{F_{R,k}}{\gamma_M} = \frac{26,9kN}{1,5} = 17,9 kN$$

The recommended partial safety factor γ_F is 1,5, provided that no partial safety factor is specified in national regulations or national annexes to Eurocode 2.

Dynamic load capacity

Maximum 4 users

Deformation capacity

≤ 10 mm at 0,70kN for a free length ≤ 600 mm over roof surface.

Fall protection SAFEX and VARIANT

GRÜN SAFEX EASY BD for concrete C20/25 to C50/60 (cracked and uncracked)

Annex 3.1

all dimensions in [mm]

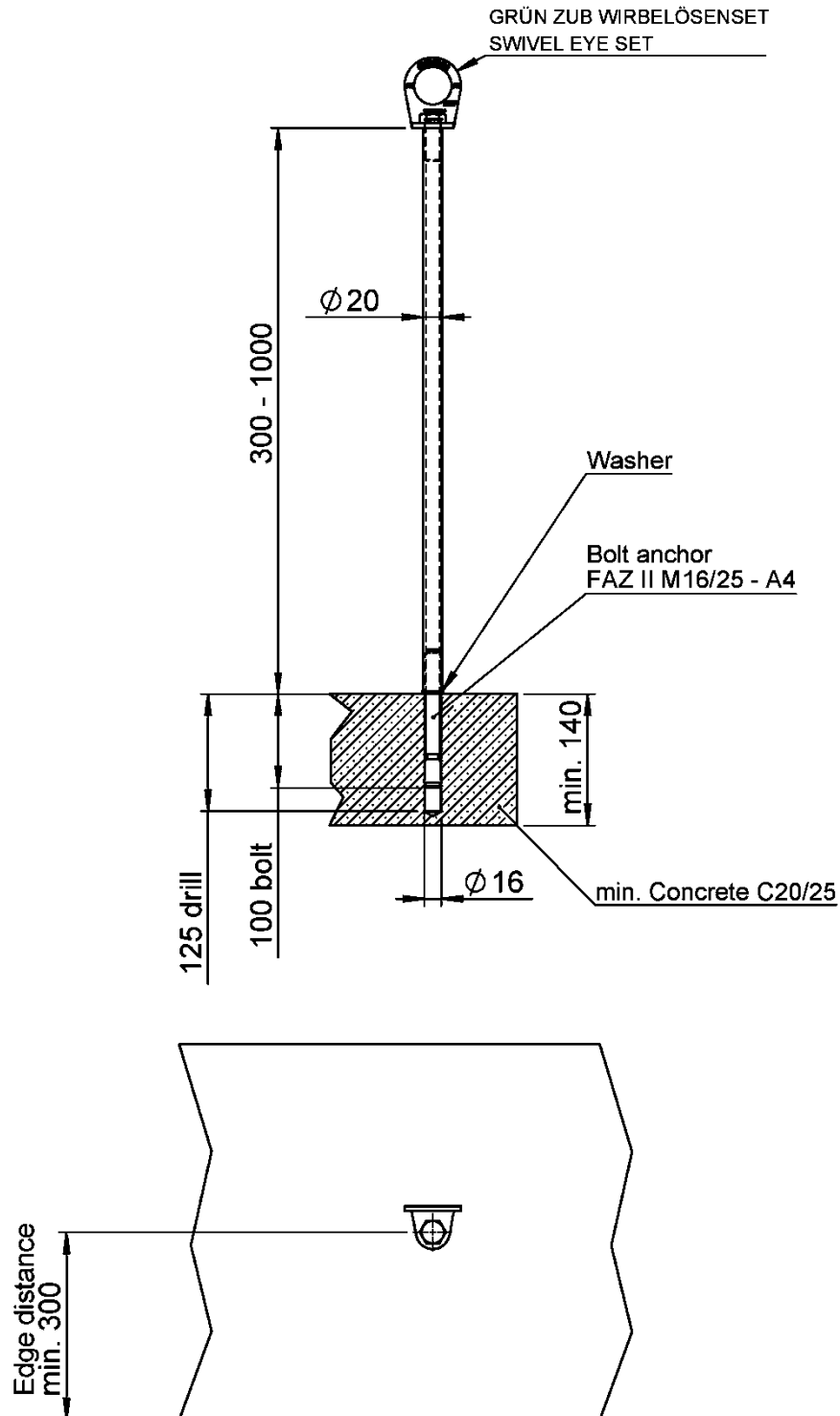

Designation in GREENLINE lifeline system
GRÜN SYS SAFEX EASY Z

Fall Protection SAFEX and VARIANT

Annex 3.2

GRÜN SAFEX EASY for concrete C20/25 till C50/60 (cracked and non-cracked)

Table 4: Substructure Reinforced concrete C20/25 to C50/60 (cracked and uncracked)

Anchor device	Bar height [mm]	Fastener	Edge distance C_{min} [mm]	Minimum substructure thickness h_{min} [mm]
SAFEX OF BD	200 - 1000	Fischer FIS SB 390 S	300	160

All components of the anchorage system can be used in weathered outdoor areas.
The concrete substructure must be pre-drilled with a borehole diameter of 18mm and a borehole depth of ≥ 125 mm must be pre-drilled.

Design resistance

$$F_{R,d} = \frac{F_{R,k}}{\gamma_M} = \frac{31,2kN}{1,5} = 20,8 kN$$

The recommended partial safety factor γ_F is 1,5, provided that no partial safety factor is specified in national regulations or national annexes to Eurocode 2.

Dynamic load capacity

Maximum 4 users

Deformation capacity

≤ 10 mm at 0,70kN for a free length ≤ 300 mm over roof surface.

Fall protection SAFEX and VARIANT

GRÜN SAFEX OF BD for concrete C20/25 to C50/60 (cracked and uncracked)

Annex 4.1

all dimensions in [mm]

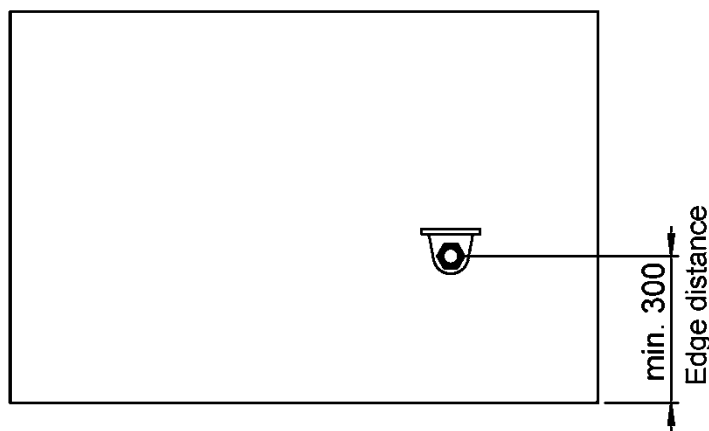
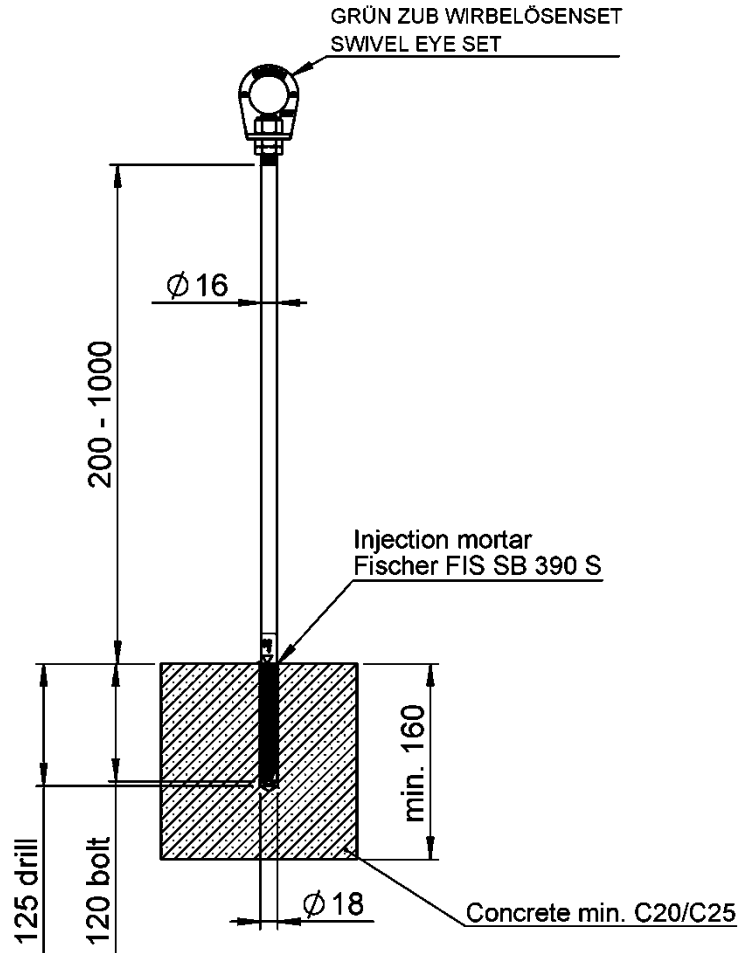

Designation in GREENLINE lifeline system
GRÜN SYS SAFEX OF BD Z

Fall Protection SAFEX and VARIANT

Annex 4.2

GRÜN EAE SAFEX OF BD for concrete C20/25 till C50/60 (cracked and non-cracked)

Table 5: Substructure Reinforced concrete C20/25 to C50/60 (cracked and uncracked)

Anchor device	Bar height [mm]	Fastener	Edge distance C_{min} [mm]	Minimum substructure thickness h_{min} [mm]
VARIANT BD	200 - 1000	EJOT BA-E Plus 12/10/- Fischer FAZ II 12/10 K A4 MKT BZ plus M12-10/85 s A4	300	120

All components of the anchorage system can be used in weathered outdoor areas.
The concrete substructure must be pre-drilled with a borehole diameter of 12mm and a borehole depth of ≥ 70 mm must be pre-drilled.

Design resistance

$$F_{R,d} = \frac{F_{R,k}}{\gamma_M} = \frac{26,1 kN}{1,5} = 17,4 kN$$

The recommended partial safety factor γ_F is 1,5, provided that no partial safety factor is specified in national regulations or national annexes to Eurocode 2.

Dynamic load capacity

Maximum 4 users

Deformation capacity

≤ 10 mm at 0,70kN

Fall protection SAFEX and VARIANT

GRÜN VARIANT BD for concrete C20/25 to C50/60 (cracked and uncracked)

Annex 5.1

all dimensions in [mm]

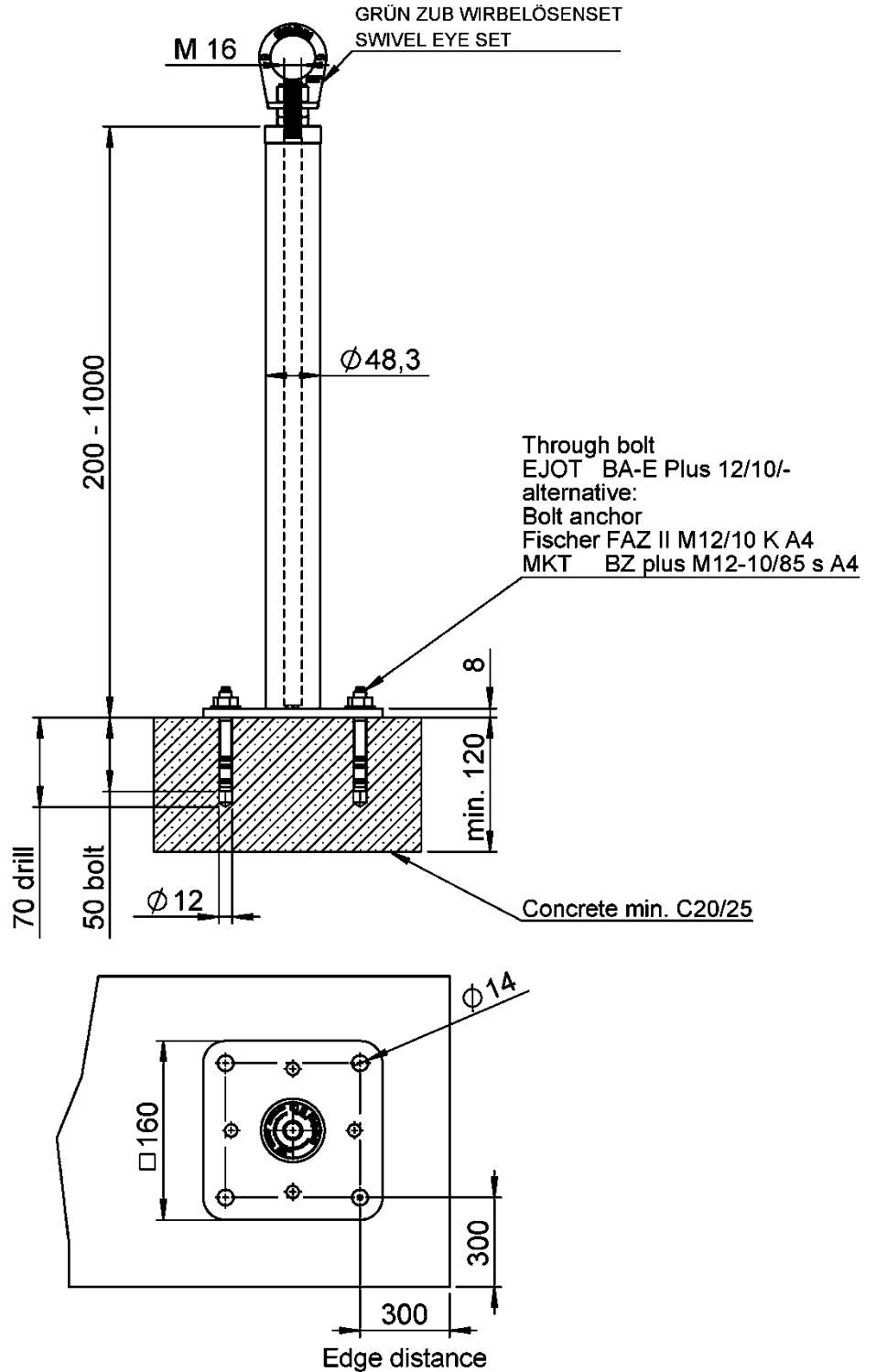

Designation in GREENLINE lifeline system

GRÜN SYS VARIANT BD

Fall Protection SAFEX and VARIANT

GRÜN VARIANT BD for concrete C20/25 till C50/60 (cracked and non-cracked)

Annex 5.2

Tabelle 6: Substructure Reinforced concrete C20/25 to C50/60 (cracked and uncracked)

Anchor device	Bar height [mm]	Fastener	Edge distance C_{min} [mm]	Minimum substructure thickness h_{min} [mm]
SAFEX LIGHT BD	40 - 600	Fischer FIS SB 390 S or EJOT MULTIFIX SE1000 SEISMIC	200	120

All components of the anchorage system can be used in weathered outdoor areas.
The concrete substructure must be pre-drilled with a borehole diameter of 18mm and a borehole depth of ≥ 100 mm must be pre-drilled.

Design resistance

$$F_{R,d} = \frac{F_{R,k}}{\gamma_M} = \frac{20,84 kN}{1.5} = 13,89 kN$$

The recommended partial safety factor γ_F is 1,5, provided that no partial safety factor is specified in national regulations or national annexes to Eurocode 2.

Dynamic load capacity

Maximum 3 users

Deformation capacity

≤ 10 mm at 0,70kN for a free length ≤ 370 mm over roof surface.

Fall protection SAFEX and VARIANT

GRÜN SAFEX LIGHT BD for concrete C20/25 to C50/60 (cracked and uncracked)

Annex 6.1

all dimensions in [mm]

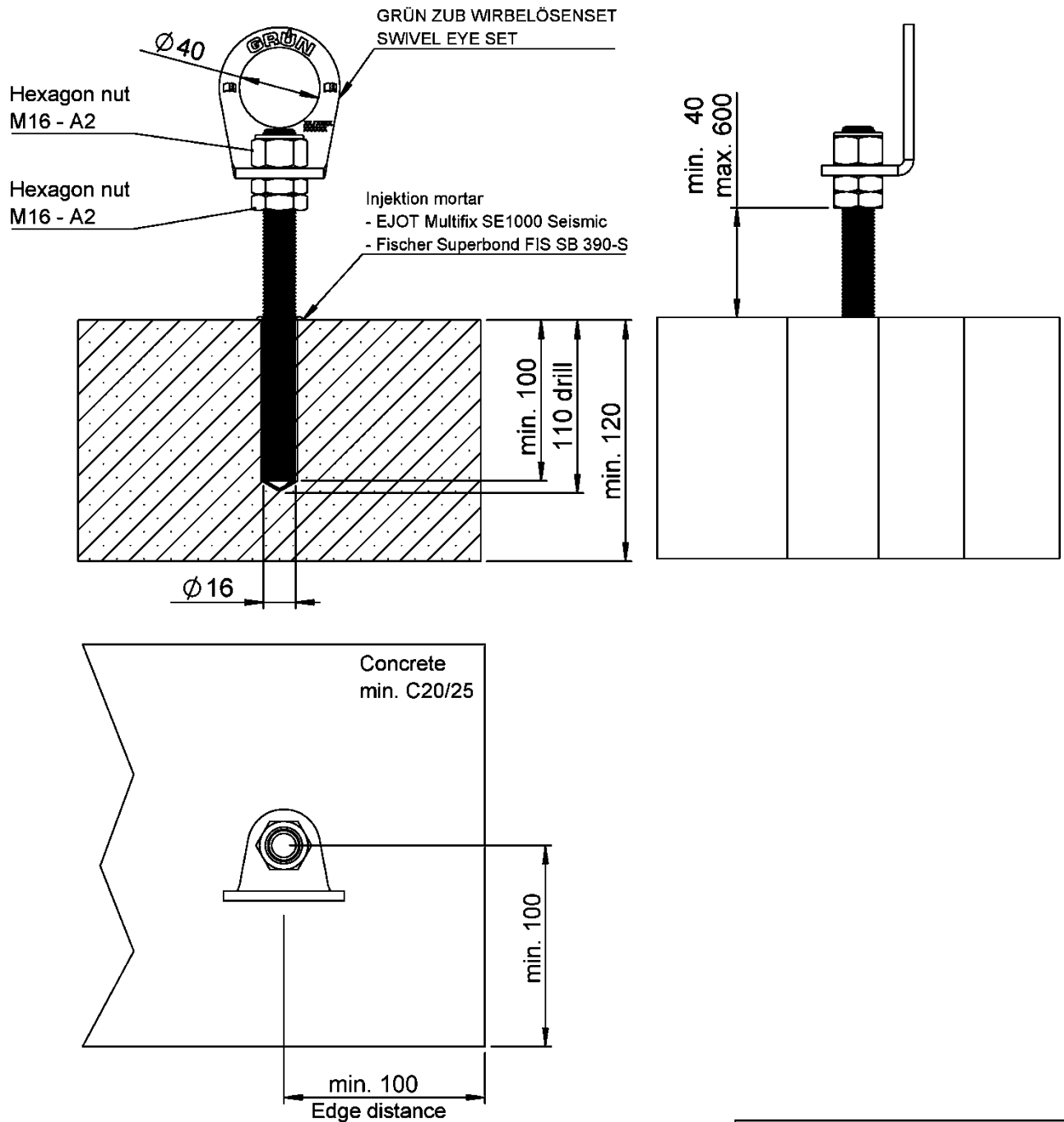

Designation in GREENLINE lifeline system
GRÜN SYS GREENLINE FZH

Fall Protection SAFEX and VARIANT

GRÜN SAFEX LIGHT BD for concrete C20/25 till C50/60 (cracked and non-cracked)

Annex 6.2

Table 7: Substrate Prestressed concrete hollow core slabs min. C45/55

Anchor device	Bar height [mm]	Fastener	Edge distance C_{min} [mm]	Minimum mirror thickness h_{min} [mm]
SAFEX MULTI HD	300 - 1000	Fischer FHY M10 A4	200	30

All components of the anchorage system can be used in weathered outdoor areas.
The concrete substructure must be pre-drilled with a borehole diameter of 16mm and a borehole depth of ≥ 65 mm must be pre-drilled.

Design resistance

$$F_{R,d} = \frac{F_{R,k}}{\gamma_M} = \frac{26,3kN}{1,5} = 17,5 kN$$

The recommended partial safety factor γ_F is 1,5, provided that no partial safety factor is specified in national regulations or national annexes to Eurocode 2.

Dynamic load capacity

Maximum 3 users

Deformation capacity

≤ 10 mm at 0,70kN for a free length ≤ 300 mm over roof surface.

Fall protection SAFEX and VARIANT

GRÜN SAFEX MULTI HD for Prestressed concrete hollow core slabs min. C45/55

Annex 7.1

all dimensions in [mm]

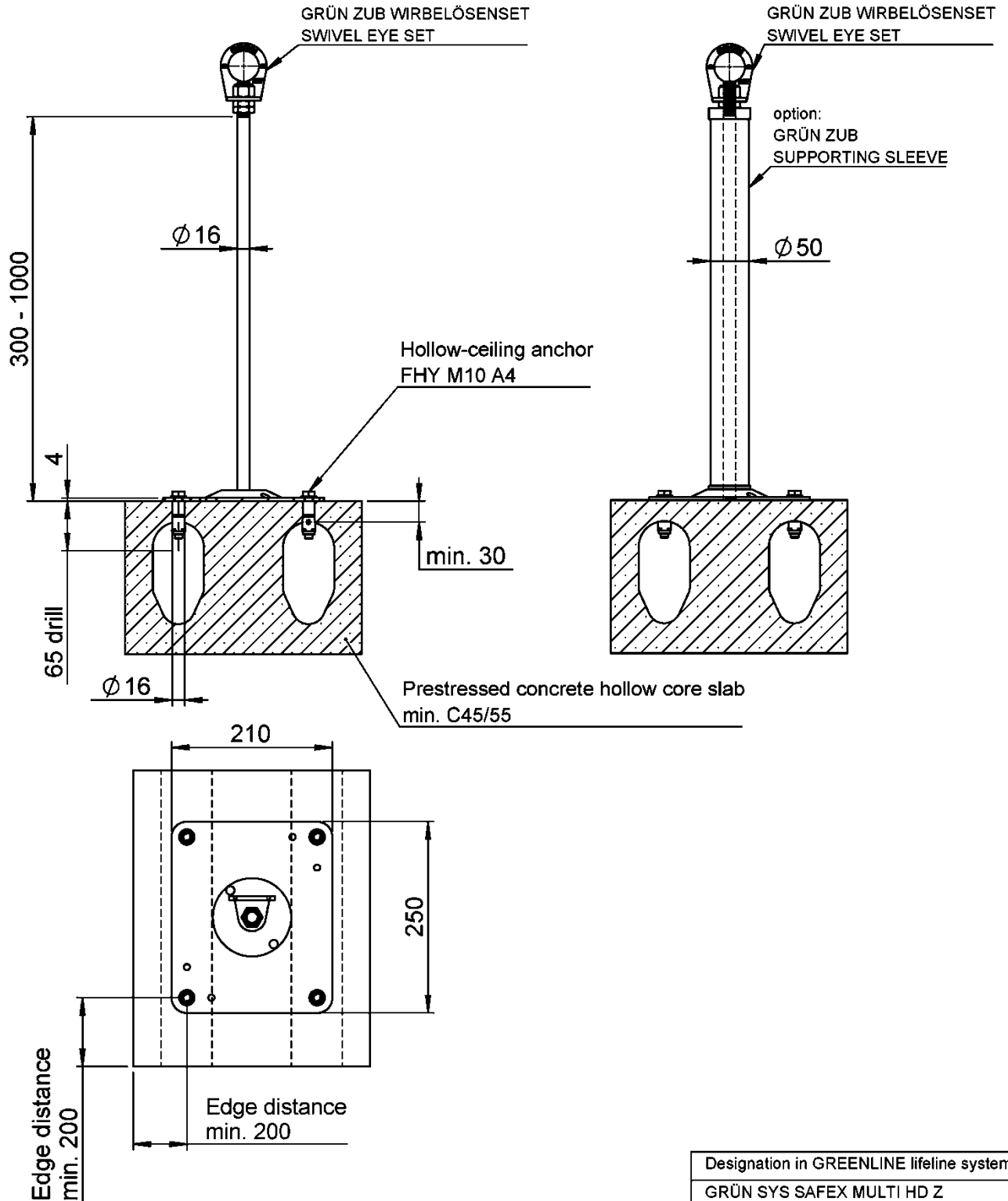

Fall Protection SAFEX and VARIANT

GRÜN SAFEX MULTI HD for prestressed concrete hollow core slab min. C45/55

Annex 7.2

Table 8: Substrate Prestressed concrete hollow core slabs min. C45/55

Anchor device	Bar height [mm]	Fastener	Edge distance c_{min} [mm]	Minimum mirror thickness h_{min} [mm]
VARIANT HD	200 - 1000	Fischer FHY M10 A4	200	40

All components of the anchorage system can be used in weathered outdoor areas.
The concrete substructure must be pre-drilled with a borehole diameter of 16mm and a borehole depth of ≥ 65 mm must be pre-drilled.

Design resistance

$$F_{R,d} = \frac{F_{R,k}}{\gamma_M} = \frac{27,1kN}{1,5} = 18,1 kN$$

The recommended partial safety factor γ_F is 1,5, provided that no partial safety factor is specified in national regulations or national annexes to Eurocode 2.

Dynamic load capacity

Maximum 4 users

Deformation capacity

≤ 10 mm at 0,70kN

Fall protection SAFEX and VARIANT	Annex 8.1
GRÜN VARIANT HD for Prestressed concrete hollow core slabs min. C45/55	

all dimensions in [mm]

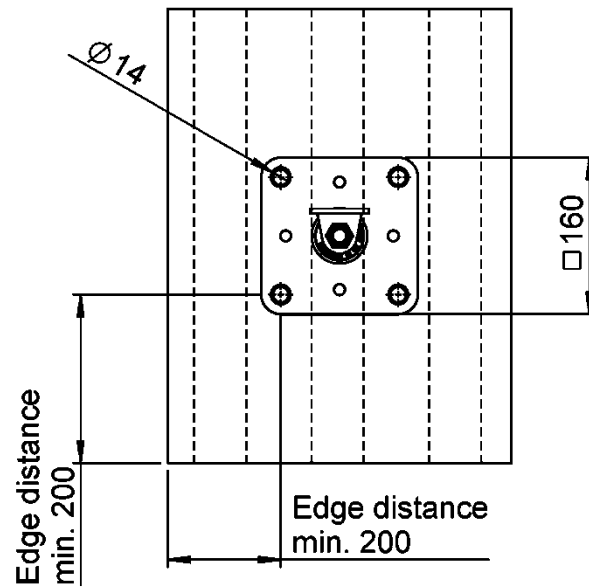
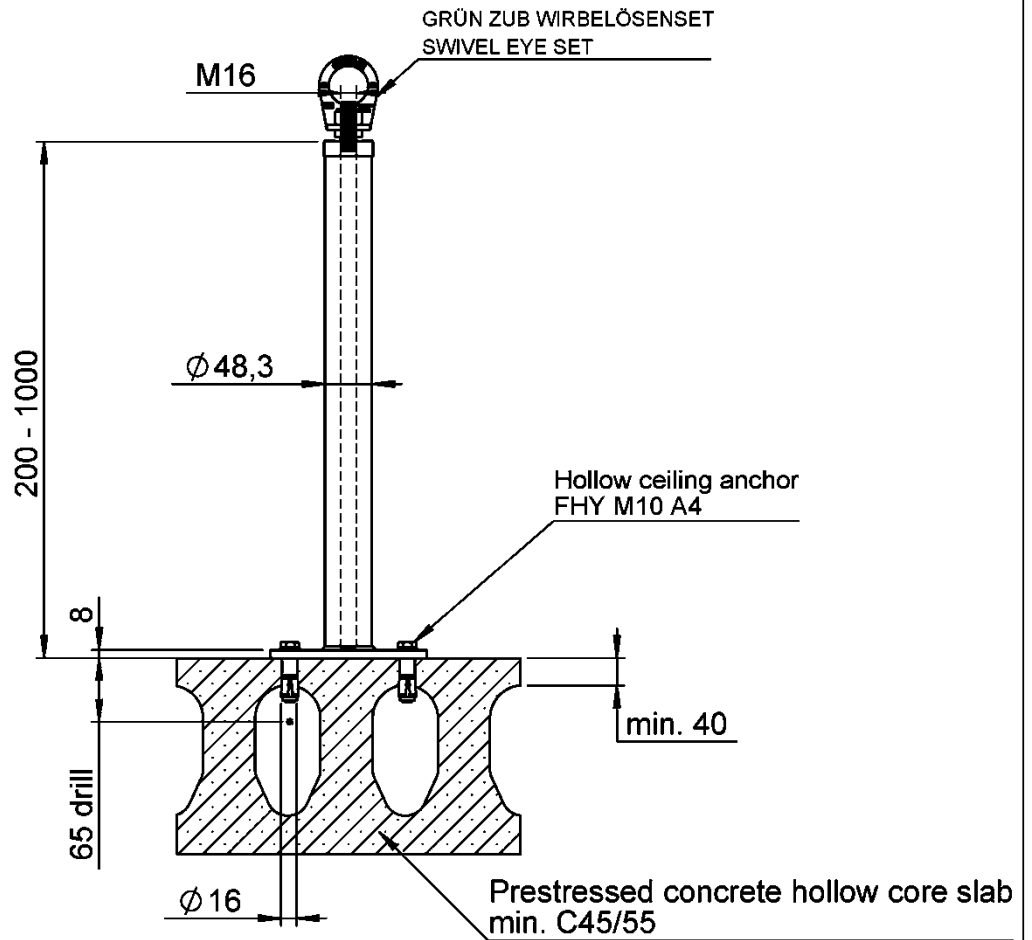

Designation in GREENLINE lifeline system
GRÜN SYS VARIANT HD

Fall Protection SAFEX and VARIANT

GRÜN VARIANT HD for prestressed concrete hollow core slab min. C45/55

Annex 8.2

Table 9: Substrate Prestressed concrete hollow core slabs min. C45/55

Anchor device	Bar height [mm]	Fastener	Edge distance c_{min} [mm]	Minimum mirror thickness h_{min} [mm]
VARIANT HD30	200 - 1000	Fischer FHY M10 A4	200	30

All components of the anchorage system (anchors and concrete) can be used in weathered outdoor areas. The concrete substructure must be pre-drilled with a borehole diameter of 16mm and a borehole depth of ≥ 65 mm must be pre-drilled.

Design resistance

$$F_{R,d} = \frac{F_{R,k}}{\gamma_M} = \frac{25,8kN}{1,5} = 17,2 kN$$

The recommended partial safety factor γ_F is 1,5, provided that no partial safety factor is specified in national regulations or national annexes to Eurocode 2.

Dynamic load capacity

Maximum 3 users

Deformation capacity

≤ 10 mm at 0,70kN

Fall protection SAFEX and VARIANT

GRÜN VARIANT HD30 for Prestressed concrete hollow core slabs min. C45/55

Annex 9.1

all dimensions in [mm]

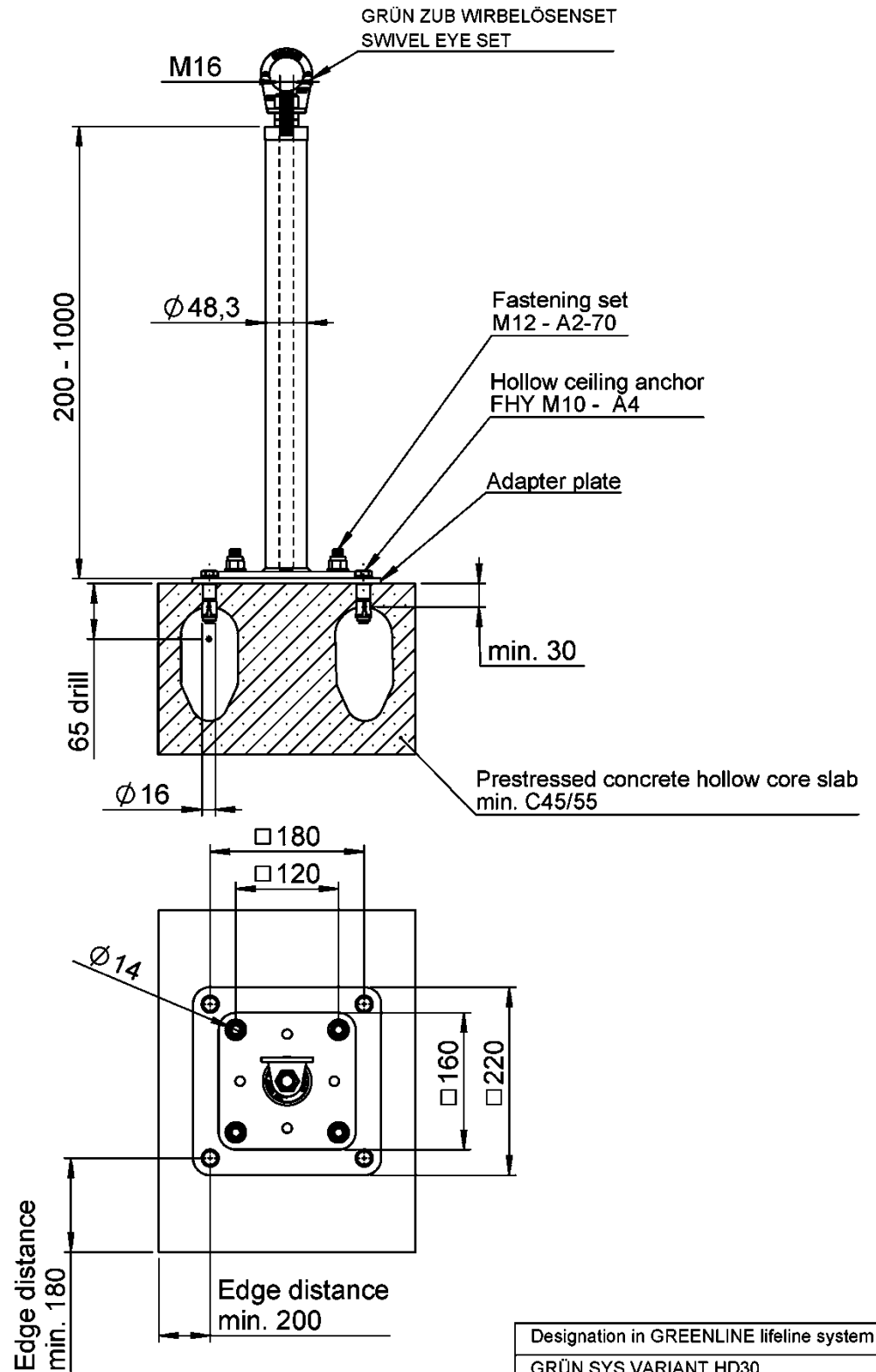

Fall Protection SAFEX and VARIANT

GRÜN VARIANT HD30 for prestressed concrete hollow core slab min. C45/55

Annex 9.2