

Public-law institution jointly founded by the federal states and the Federation

European Technical Assessment Body
for construction products



European Technical Assessment

ETA-24/0286
of 12 June 2024

English translation prepared by DIBt - Original version in German language

General Part

Technical Assessment Body issuing the European Technical Assessment:

Deutsches Institut für Bautechnik

Trade name of the construction product

Sympafix construction plug CP-PLUS

Product family to which the construction product belongs

Plastic anchors for redundant non-structural systems in concrete and masonry

Manufacturer

Sympafix B.V.
Fluorietweg 25E
1812RR ALKMAAR
NIEDERLANDE

Manufacturing plant

Factory RC

This European Technical Assessment contains

26 pages including 3 annexes which form an integral part of this assessment

This European Technical Assessment is issued in accordance with Regulation (EU) No 305/2011, on the basis of

EAD 330284-00-0604, edition 12/2020

The European Technical Assessment is issued by the Technical Assessment Body in its official language. Translations of this European Technical Assessment in other languages shall fully correspond to the original issued document and shall be identified as such.

Communication of this European Technical Assessment, including transmission by electronic means, shall be in full. However, partial reproduction may only be made with the written consent of the issuing Technical Assessment Body. Any partial reproduction shall be identified as such.

This European Technical Assessment may be withdrawn by the issuing Technical Assessment Body, in particular pursuant to information by the Commission in accordance with Article 25(3) of Regulation (EU) No 305/2011.

Specific part

1 Technical description of the product

The Sympafix construction plug CP-PLUS is a plastic anchor consisting of a plastic sleeve made of polyamide and an accompanying specific screw of galvanised steel or of stainless steel.

The plastic sleeve is expanded by screwing in the specific screw which presses the sleeve against the wall of the drilled hole.

The product description is given in Annex A.

2 Specification of the intended use in accordance with the applicable European Assessment Document

The performances given in Section 3 are only valid if the anchor is used in compliance with the specifications and conditions given in Annex B.

The verifications and assessment methods on which this European Technical Assessment is based lead to the assumption of a working life of the anchors of at least 50 years. The indications given on the working life cannot be interpreted as a guarantee given by the producer, but are to be regarded only as a means for choosing the right products in relation to the expected economically reasonable working life of the works.

3 Performance of the product and references to the methods used for its assessment

3.1 Safety in case of fire (BWR 2)

Essential characteristic	Performance
Reaction to fire	Class A1
Resistance to fire	See Annex C3

3.2 Mechanical resistance and stability (BWR 4)

Essential characteristic	Performance
Resistance to steel failure under tension loading	See Annex C1
Resistance to steel failure under shear loading	See Annex C1
Resistance to pull-out or concrete failure under tension loading (base material group a)	See Annex C2
Resistance in any load direction without lever arm (base material group b, c, d)	See Annexes C4 – C6 and C8
Edge distance and spacing (base material group a)	See Annex B3
Edge distance and spacing (base material group b, c, d)	See Annex B4 and B5
Displacements under short-term and long-term loading	See Annex C3, C7, C9
Durability	See Annex B1

4 Assessment and verification of constancy of performance (AVCP) system applied, with reference to its legal base

In accordance with European Assessment Document EAD 330284-00-0604 the applicable European legal act is: 97/463/EC.

The system to be applied is: 2+

5 Technical details necessary for the implementation of the AVCP system, as provided for in the applicable EAD

Technical details necessary for the implementation of the AVCP system are laid down in the control plan deposited with Deutsches Institut für Bautechnik.

Issued in Berlin on 12 June 2024 by Deutsches Institut für Bautechnik

Dipl.-Ing. Beatrix Wittstock
Head of Section

beglaubigt:
Ziegler

Intended use in hollow brick

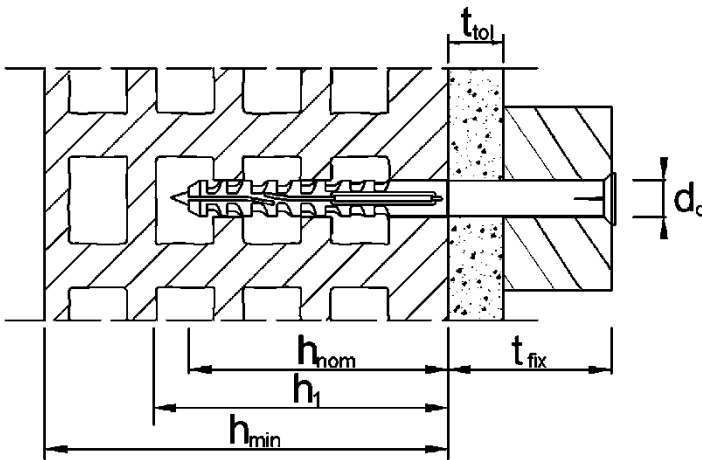

Intended use in concrete or solid base material

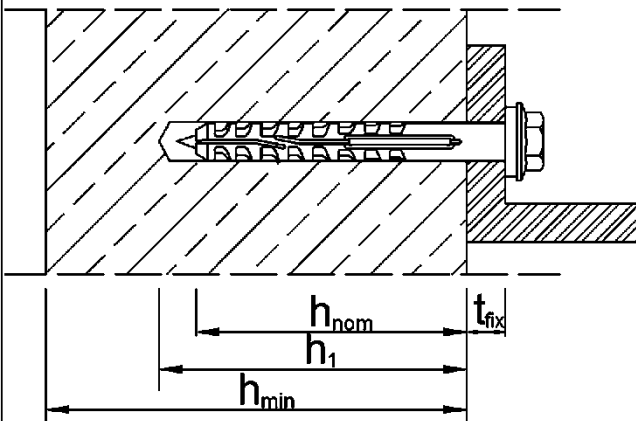

Intended use in precast prestressed hollow core slabs

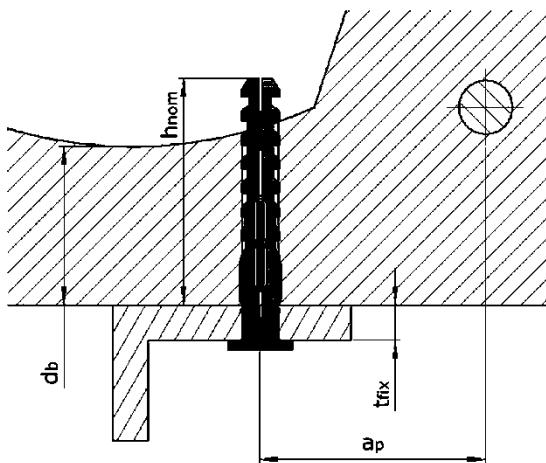

- h_{nom} = overall plastic anchor embedment depth in the base material
- h_1 = depth of drilled hole to deepest point
- h_{min} = Minimum thickness of member
- t_{fix} = thickness of fixture
- t_{tol} = thickness of layer or non-load bearing coating
- d_b = mirror thickness
- a_p = distance between plug and reinforcement

Sympafix construction plug CP-PLUS

Product description
Installed condition

Annex A1

Anchor sleeve CP-PLUS 8

Sleeve with flat head (ZK) or countersunk head (VK)

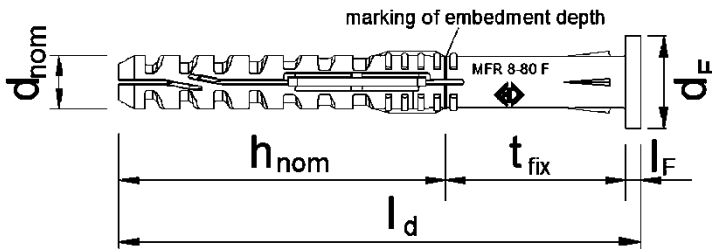

CP-PLUS 8 ZK

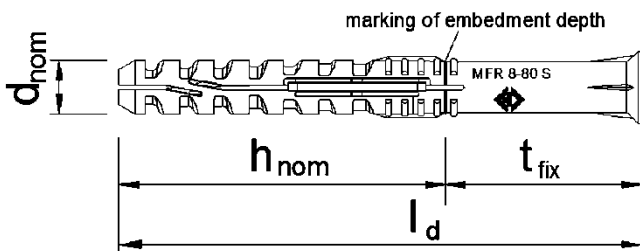

CP-PLUS 8 VK

Marking:	Brand	Type	diameter (d_{nom}) - length (l_d)	plug head form (optional)
Example:	CELO (or Logo)	MFR	8 - 80	F or S (F = ZK) (S = VK)

Special screw (for CP-PLUS 8)

Screw head with different tool fittings

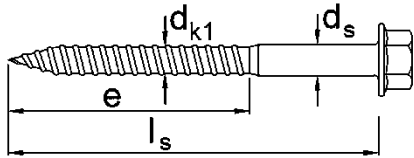

Type SSKS (or SSKS A4)
galvanised steel or stainless steel (A4)



Type SSK (or SSK A4)
galvanised steel or stainless steel (A4)



Type TX (or TX A4)
galvanised steel or stainless steel (A4)



Type E (or E A4)
galvanised steel or stainless steel (A4)



Type M (or M A4)
galvanised steel or stainless steel (A4)

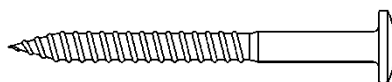

Type PT (or PT A4)
galvanised steel or stainless steel (A4)

Marking:	Brand	Code No plug length	manufacturer code	if stainless steel
Example:	X or C	12 or 120	1	A4

Sympafix construction plug CP-PLUS

Product description
CP-PLUS 8 – Anchor types, screw specification, marking

Annex A2

Anchor sleeve CP-PLUS 10

Sleeve with flat head (ZK) or countersunk head (VK)

CP-PLUS 10 ZK

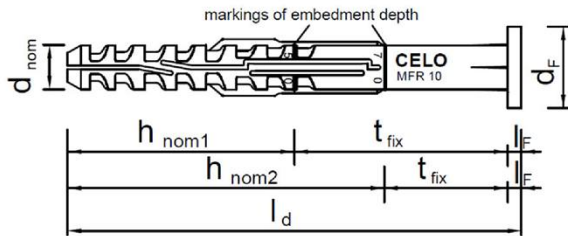

CP-PLUS 10 ZK (alternative)

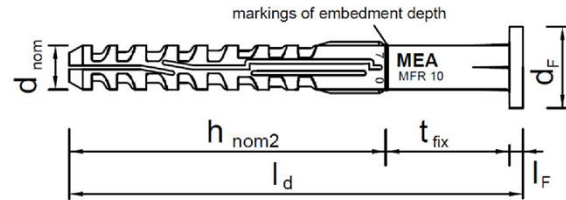

CP-PLUS 10 VK

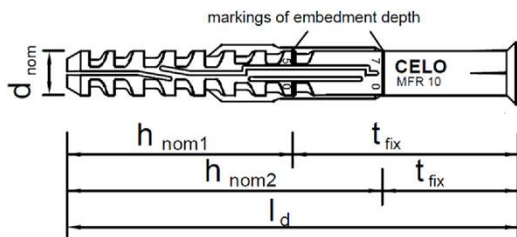

CP-PLUS 10 VK (alternative)

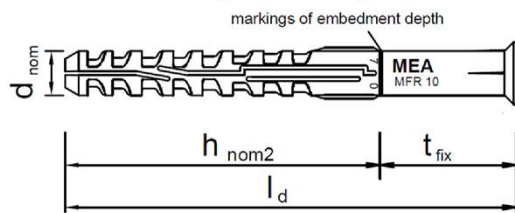

Marking:	Brand	Type	diameter (d_{nom})	length (l_d)	plug head form (optional)
Example:	CELO (or MEA or Logo)	MFR	10	100	F or S (F = ZK) (S = VK)

Special screw (for CP-PLUS 10)

Screw head with different tool fittings

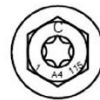
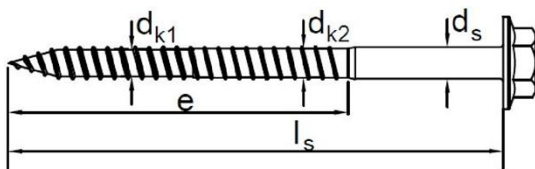

Type SSKS (or SSKS A4)
galvanised steel or stainless steel (A4)



Type TX (or SSK A4)
galvanised steel or stainless steel (A4)

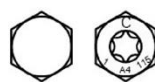

Type SSK (or SSK A4)
galvanised steel or stainless steel (A4)



Type E (or E A4)
galvanised steel or stainless steel (A4)



Type M (or M A4)
galvanised steel or stainless steel (A4)

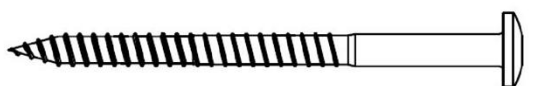

Type PT (or PT A4)
galvanised steel or stainless steel (A4)

Marking:	Brand	Code No plug length	manufacturer code	if stainless steel
Example:	X or C	12 or 115	1	A4

Sympafix construction plug CP-PLUS

Product description
CP-PLUS 10 – Anchor types, screw specification, marking

Annex A3

Anchor sleeve CP-PLUS 10-60

Sleeve with flat head (ZK) or countersunk head (VK)

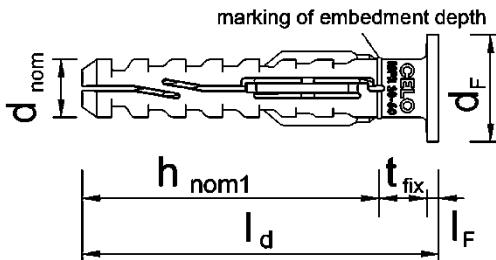

CP-PLUS 10-60 ZK

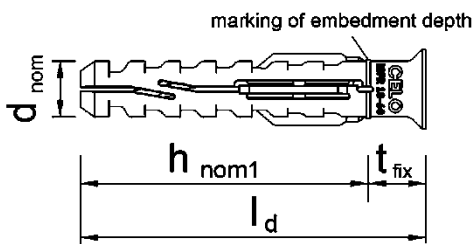

CP-PLUS 10-60 VK

Marking:	Brand	Type	diameter (d_{nom}) - length (l_d)	plug head form (optional)
Example:	CELO (or Logo)	MFR	10 60	F or S (F = ZK) (S = VK)

Special screw (for CP-PLUS 10-60)

Screw head with different tool fittings

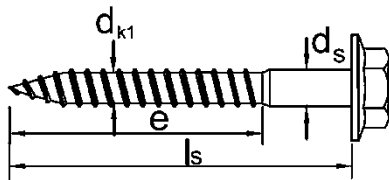

Type SSKS (or SSKS A4)
galvanised steel or
stainless steel (A4)



Type SSK (or SSK A4)
galvanised steel or
stainless steel (A4)



Type TX (or TX A4)
galvanised steel or
stainless steel (A4)

Marking:	Brand	Code No plug length	manufacturer code	if stainless steel
Example:	X or C	6 or 60	1	A4

Sympafix construction plug CP-PLUS

Product description
CP-PLUS 10-60 – Anchor types, screw specification, marking

Annex A4

Anchor sleeve CP-PLUS 14

Sleeve with flat head (ZK) or countersunk head (VK)

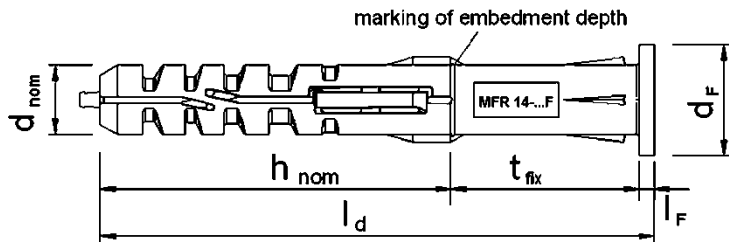

CP-PLUS 14 ZK

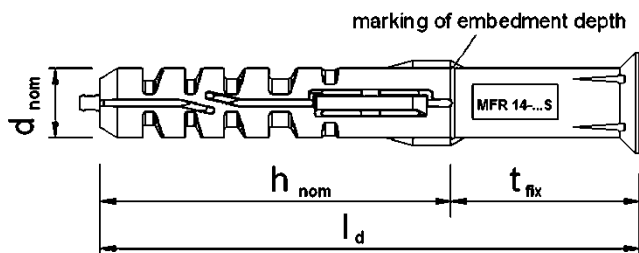

CP-PLUS 14 VK

Marking:	Brand	Type	diameter (d_{nom}) - length (l_d)		plug head form (optional)
Example:	MEA (or CELO or Logo)	MFR	14	- 110	F or S (F = ZK) (S = VK)

Special screw (for CP-PLUS 14)

Screw head with different tool fittings

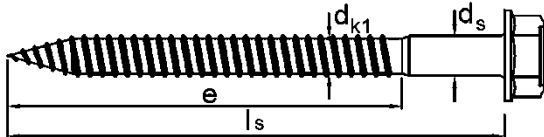

Type SSKS (or SSKS A4)
galvanised steel or stainless steel
(A4), optional with glide coating



Type TX (or TX A4)
galvanised steel or stainless steel (A4)
optional with glide coating



Type E (or E A4)
galvanised steel or stainless steel (A4)
optional with glide coating



Type M (or M A4)
galvanised steel or stainless steel (A4)
optional with glide coating



Type PT (or PT A4)
galvanised steel or stainless steel (A4)
optional with glide coating

Marking:	Brand	Code No plug length	manufacturer code	if stainless steel
Example:	X or C	11 or 110	1	A4

Sympafix construction plug CP-PLUS

Product description
CP-PLUS 14 – Anchor types, screw specification, marking

Annex A5

Table A5.1: Dimensions [mm]

	Anchor sleeve							
	l_d	$\varnothing d_{nom}$	$t_{fix\ min}$	$t_{fix\ max}$	h_{nom1}	h_{nom2}	l_F ²⁾	$\varnothing d_F$
CP-PLUS 8	≥ 60	8	≥ 1	110	50		2,3	14
CP-PLUS 10	≥ 80	10	≥ 1	500	50	70	3	18
CP-PLUS 10-60	60	10	≥ 1	10	50		2	18
CP-PLUS 14	≥ 80	14	≥ 1	500	70		3	22

	Special screw				
	l_s ¹⁾	$\varnothing d_s$	$\varnothing d_{k1}$	$\varnothing d_{k2}$	e
for CP-PLUS 8	≥ 65	6	5,2	-	≤ 48
for CP-PLUS 10	≥ 85	7	5,8	6,3	≤ 75
for CP-PLUS 10-60	65	7	5,8	-	≤ 48
for CP-PLUS 14	≥ 85	10	8,4	-	≤ 75

¹⁾ To insure, that the screw penetrates the anchor sleeve, l_s must be $l_d + 5$ mm

²⁾ only valid for plan head version

Table A5.2: Materials

Designation	Material
anchor sleeve	Polyamid PA 6
special screw (steel, zinc plated)	Steel, zinc plated galvanised $\geq 5 \mu m$ acc. EN ISO 4042:2022 $f_{yk} \geq 480 \text{ N/mm}^2$, $f_{uk} \geq 600 \text{ N/mm}^2$ (≥ 6.8 screw)
special screw (stainless steel)	Stainless steel A4 according to EN 10088-3:2014, material 1.4401 or 1.4571 $f_{yk} \geq 450 \text{ N/mm}^2$, $f_{uk} \geq 700 \text{ N/mm}^2$ strength class 70

Sympafix construction plug CP-PLUS

Product description
Dimensions and materials

Annex A6

<p><u>Specifications of intended use</u></p> <p>Anchorage subject to:</p> <ul style="list-style-type: none"> • Static and quasi-static loads. • Redundant non-structural systems. <p>Base materials:</p> <ul style="list-style-type: none"> • Reinforced or unreinforced normal weight concrete without fibres with strength classes \geq C12/15 (base material group a) according to EN 206:2013+A1:2016, Annex C2 and Annex C3. • Precast prestressed hollow core slabs with strength classes \geq C20/25 (base material group a) according to EN 206:2013+A1:2016, see Annex C2 • Solid brick masonry (base material group b) according to EN 771-1/-2/-3:2011+A1:2015, see Annex C4-C6 Note: The characteristic resistance is also valid for larger brick sizes and higher compressive strength of the masonry unit. • Hollow brick masonry (base material group c) according to EN 771-1/-2/-3:2011+A1:2015, see Annex C4-C6 • Autoclaved aerated concrete (base material group d) according to EN 771-4:2011+A1:2015, see Annex C8 • Mortar strength class of the masonry \geq M2,5 according to EN 998-2:2010. • For other base materials of the base material groups a, b, c or d the characteristic resistance of the anchor may be determined by job site tests according to EOTA TR 051:2018-04. <p>Temperature Range for use:</p> <ul style="list-style-type: none"> • a: - 40° C to + 40° C (max. short term temperature + 40° C and max long term temperature + 24° C) • b: - 40° C to + 80° C (max. short term temperature + 80° C and max long term temperature + 50° C) <p>Use conditions (Environmental conditions):</p> <ul style="list-style-type: none"> • Structures subject to dry internal conditions (screw made of zinc coated steel, stainless steel) • The specific screw made of galvanised steel may also be used in structures to external atmospheric exposure, if the area of the head of the screw is protected against moisture and driving rain after mounting of the fixing unit in this way, that intrusion of moisture into the anchor shaft is prevented. Therefore there shall be an external cladding or a ventilated rainscreen mounted in front of the head of the screw and the head of the screw itself shall be coated with a soft plastic, permanently elastic bitumen-oil-combination coating (e. g. undercoating or body cavity protection for cars) • Structures subject to external atmospheric exposure (including industrial and marine environment) and to permanently damp internal condition, if no particular aggressive conditions exist (screw made of stainless steel). Note: Particular aggressive conditions are e.g. permanent, alternating immersion in seawater or the splash zone of seawater, chloride atmosphere of indoor swimming pools or atmosphere with extreme chemical pollution (e.g. in desulphurization plants or road tunnels where de-icing materials are used). <p>Design:</p> <ul style="list-style-type: none"> • The anchorages are to be designed in accordance with EOTA TR 064:2018-05 under the responsibility of an engineer experienced in anchorages and masonry work. • Verifiable calculation notes and drawings shall be prepared taking account of the loads to be anchored, the nature and strength of the base materials and the dimensions of the anchorage members as well as of the relevant tolerances. The position of the anchor is indicated on the design drawings. <p>Installation:</p> <ul style="list-style-type: none"> • Hole drilling by the drill methods according to Annex C4, C5 or C6 for base material group b and c and according to Annex C8 for base material group d, hammer drilling is to be used for base material group a. • Anchor installation carried out by appropriately qualified personnel and under the supervision of the person responsible for technical matters of the site. • Temperature of the plug at installation from 0°C to + 50°C. • Exposure to UV due to solar radiation of the anchor not protected \leq 6 weeks. • No ingress of water in the borehole at temperatures $<$ 0°C 	
<p>Sympafix construction plug CP-PLUS</p>	
<p>Intended use Specifications</p>	
<p>Annex B1</p>	

Table B2.1: Installation parameter in concrete, masonry and autoclaved aerated concrete

Anchor type			CP-PLUS 8	CP-PLUS 10-60/ CP-PLUS 10	CP-PLUS 10	CP-PLUS 14
Overall plastic anchor embedment depth in the base material ^{1), 2)}	$h_{nom} \geq$	[mm]	50	50	70	70
Drill hole diameter	$d_0 <$	[mm]	8	10		14
Cutting diameter of drill bit	$d_{cut} \leq$	[mm]	8,45	10,45		14,50
Depth of drill hole to the deepest point ¹⁾	$h_1 \geq$	[mm]	60	60	80	80
Diameter of clearance hole in the fixture	$d_f \leq$	[mm]	9,0	11		15

¹⁾ See Annex A1

²⁾ For hollow and perforated masonry the influence of
 $h_{nom} > 50$ mm (CP-PLUS 8)
 $h_{nom1} > 50$ mm respectively $h_{nom2} > 70$ mm (CP-PLUS 10)
 $h_{nom} > 70$ mm (CP-PLUS 14)
has to be detected by job site tests according to EOTA TR 051

Table B2.2: Installation parameter in precast prestressed hollow core slabs

Anchor type			CP-PLUS 8	CP-PLUS 10-60/ CP-PLUS 10	CP-PLUS 10
Overall plastic anchor embedment depth in the base material	$h_{nom} \geq$	[mm]	50	50	70
Drill hole diameter	$d_0 <$	[mm]	8	10	10
Cutting diameter of drill bit	$d_{cut} \leq$	[mm]	8,45	10,45	10,45
Depth of drill hole to the deepest point ¹⁾	$h_1 \geq$	[mm]	60	60	80
Diameter of clearance hole in the fixture	$d_f \leq$	[mm]	9,0	11	11
Bottom flange thickness	$d_b \geq$	[mm]	35	35	35
Distance between plug position and prestressing steel	$a_p \geq$	[mm]	50	50	50

¹⁾ See Annex A1

Sympafix construction plug CP-PLUS

Product description

Installation parameters in concrete, masonry, autoclaved aerated concrete and hollow core slabs

Annex B2

Table B3.1: Minimum thickness of member, edge distance and anchor spacing in concrete

	Minimum member thickness h_{min} [mm]	Characteristic edge distance $c_{cr,N}$ [mm]	Characteristic spacing $s_{cr,N}$ [mm]	Minimum edge distance c_{min} [mm]	Minimum spacing s_{min} [mm]
CP-PLUS 8					
Beton \geq C16/20	100	50	55	60	50
Beton C12/15	100	70	80	85	70
CP-PLUS 10-60/ CP-PLUS 10 $h_{nom1} = 50$ mm					
Beton \geq C16/20	100	50	75	50	50
Beton C12/15	100	70	105	70	70
CP-PLUS 10 $h_{nom2} = 70$ mm					
Beton \geq C16/20	110	70	75	60	50
Beton C12/15	110	100	105	85	70
CP-PLUS 14					
Beton \geq C16/20	120	80	100	100	100
Beton C12/15	120	112	140	140	140

Table B3.2: Minimum thickness of member, edge distance and anchor spacing in precast prestressed hollow core slabs

	Minimum thickness h_{min} [mm]	Characteristic edge distance $c_{cr,N}$ [mm]	Minimum edge distances c_{min} [mm]	Minimum spacing s_{min} [mm]
CP-PLUS 8				
Concrete \geq C45/55	200	50	60	50
CP-PLUS 10/ CP-PLUS 10-60 $h_{nom1}=50$ mm				
Concrete \geq C20/25	200	70	60	50
CP-PLUS 10 $h_{nom2}=70$ mm				
Concrete \geq C45/55	200	70	60	50

Sympafix construction plug CP-PLUS

Intended use
Minimum thickness, spacing, edge distance in concrete and hollow core slabs

Annex B3

Table B4: Minimum thickness of member, edge distance and anchor spacing in masonry

Base material ¹⁾	Minimum thickness of member	Minimum edge distance	Minimum spacing		
			Single anchor	Anchor Group ²⁾	
				perpendicular to free edge	parallel to free edge
h_{min} [mm]	c_{min} [mm]	a_{min} [mm]	$s_{1,min}$ [mm]	$s_{2,min}$ [mm]	
CP-PLUS 8					
Clay brick Mz-1.8 – NF	115	100	³⁾	200	400
Sand-lime solid brick KS – 2DF	115	100	³⁾	200	400
Hollow clay brick HLz 12-1.0 - 12DF	240	100	³⁾	200	400
Hollow clay brick HLz 1 (Gero Tochana)	125	100	³⁾	200	400
Hollow clay brick HLz 2 (Gero Tejala)	135	100	³⁾	200	400
Hollow light concrete block Hbl 7 (Bloque hormigon)	200	100	³⁾	200	400
Hollow sand-lime brick KSL 12-1.4 - 3DF	175	100	³⁾	200	400
Hollow light concrete block Hbl 2-0.8-16DF	240	100	³⁾	200	400
Hollow concrete block Hbn 1.4 - 12DF	240	100	³⁾	200	400
CP-PLUS 10-60/ CP-PLUS 10 $h_{nom1} = 50$ mm					
Clay brick Mz-1.8 2DF	115	100	³⁾	200	400
Sand-lime solid brick KS - 3DF	175	100	³⁾	200	400
Hollow clay brick HLz 12-1.0 - 12DF	240	100	³⁾	200	400
Hollow clay brick HLz 1 (Gero Tochana)	125	100	³⁾	200	400
Hollow clay brick HLz 2 (Gero Tejala)	135	100	³⁾	200	400
Hollow light concrete block Hbl 7 (Bloque hormigon)	200	100	³⁾	200	400
Hollow sand-lime brick KSL 12-1.4 - 8DF	240	100	³⁾	200	400
Hollow concrete block Hbn 1.4 - 12DF	240	100	³⁾	200	400
CP-PLUS 10 $h_{nom2} = 70$ mm					
Clay brick Mz-1.8 - 2DF	115	100	³⁾	200	400
Sand-lime solid brick KS - 2DF	115	100	³⁾	200	400
Hollow clay brick HLz 12-1.0 - 2DF	115	100	³⁾	200	400
Hollow sand-lime brick KSL 12-1.4 - 8DF	240	100	³⁾	200	400
Hollow clay brick Brique Creuse C 3-0.7	200	100	³⁾	200	400
Hollow concrete block Hbn 1.4 - 12DF	240	100	³⁾	200	400
CP-PLUS 14					
Clay brick Mz-1.8 NF	115	100	³⁾	200	400
Sand-lime solid brick KS - 8DF	240	100	³⁾	200	400
Sand-lime solid brick KS - 2DF	115	100	³⁾	200	400
Hollow clay brick HLz 12-1.0 - 2DF	115	120	³⁾	240	480
Hollow sand-lime brick KSL 12-1.4 - 8DF	240	100	³⁾	200	400

¹⁾ Information for base material masonry: see Annex C4, Table C4

²⁾ The design method is valid for single anchors and anchor groups with two or four anchors.

³⁾ $a_{min} = \max(250 \text{ mm}; s_{1,min}; s_{2,min})$

Sympafix construction plug CP-PLUS

Intended use
Minimum thickness, spacing, edge distance in masonry

Annex B4

Table B5: Minimum thickness of member, edge distance and anchor spacing in autoclaved aerated concrete

	Minimum thickness of member	Minimum edge distance	Minimum spacing		
			Single anchor	Anchor Group ¹⁾	
				perpendicular to free edge	parallel to free edge
Autoclaved aerated concrete with mean compressive strength according to EN 771-4	h_{min} [mm]	c_{min} [mm]	a_{min} [mm]	$s_{1,min}$ [mm]	$s_{2,min}$ [mm]
CP-PLUS 8 $h_{nom} = 50$ mm					
$f_{cm,decl} \geq 2$ N/mm ²	240	50	2)	200	400
$f_{cm,decl} \geq 3,5$ N/mm ²	240	90	2)	200	400
$f_{cm,decl} \geq 6$ N/mm ²	240	150	2)	200	400
CP-PLUS 10 and CP-PLUS 14 $h_{nom2} = 70$ mm					
$f_{cm,decl} \geq 2$ N/mm ²	100	50	2)	100	200
$f_{cm,decl} \geq 4$ N/mm ²	100	75	2)	150	300
$f_{cm,decl} \geq 6$ N/mm ²	100	150	2)	200	400

¹⁾ The design method is valid for single anchors and anchor groups with two or four anchors.

²⁾ $a_{min} = \max(250 \text{ mm}; s_{1,min}; s_{2,min})$

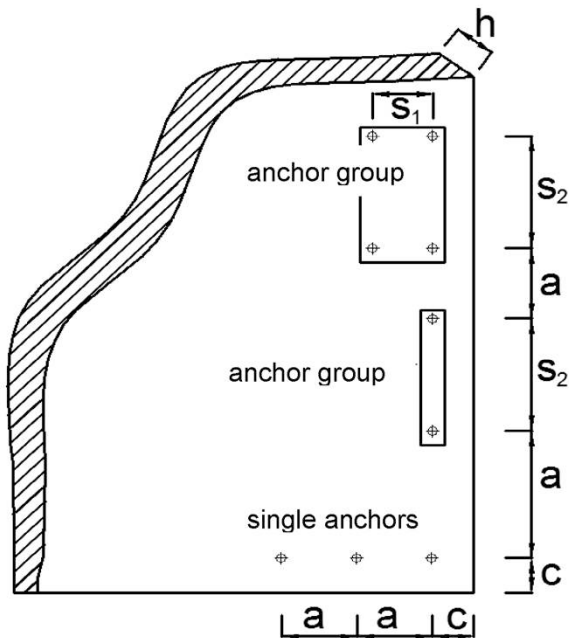

Sympafix construction plug CP-PLUS

Intended use

Minimum thickness, spacing, edge distance in autoclaved aerated concrete

Annex B5

Table B6: Geometry of stones

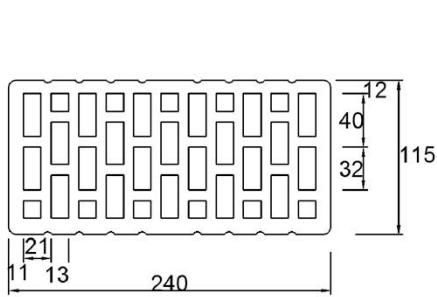

Figure 1 HLz 12 2DF

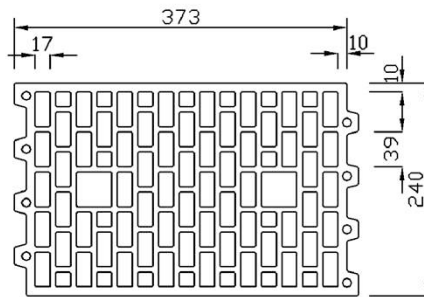

Figure 2 HLz 12 12DF

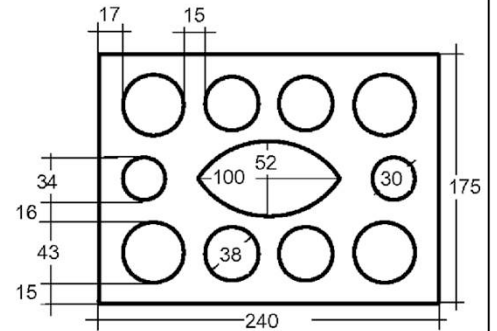

Figure 3 KSL 12-1.4- 3DF

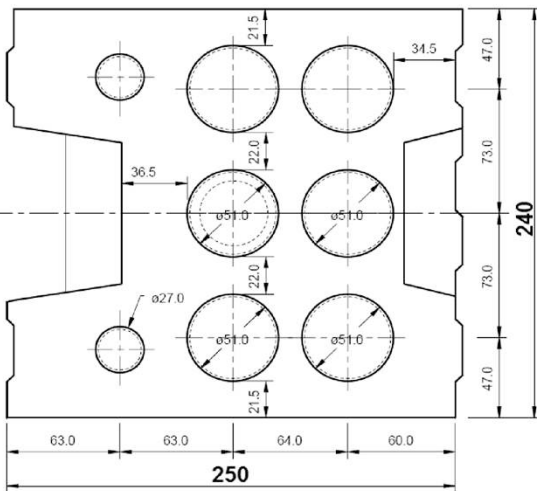

Figure 4 KSL 12 8DF

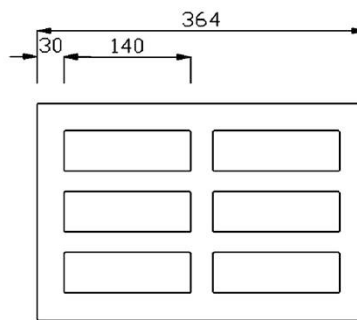

Figure 5 Hbn 1,4 12DF

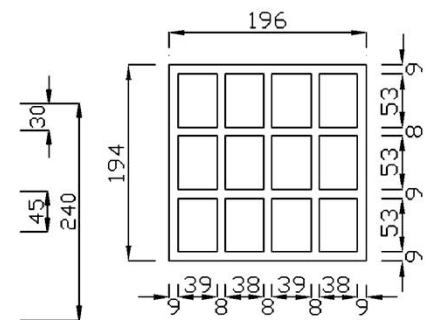

Figure 6 Brique Creuse

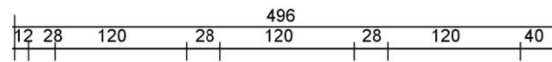

Figure 7 Hbl 2-0,8 16DF

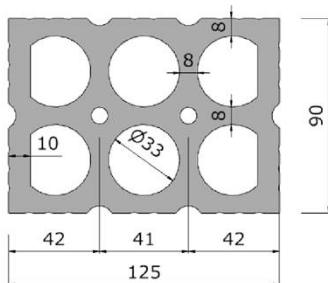

Fig. 8 HLz 1 brick with round holes
(Gero Tochana)

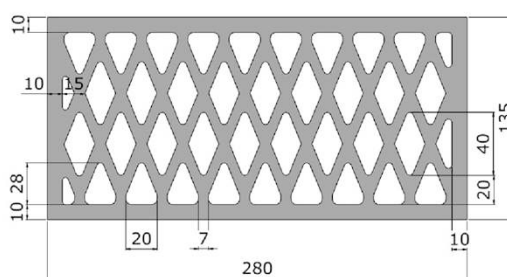

Fig. 9 HLz 2 brick with rhomb holes
(Gero Tejala)

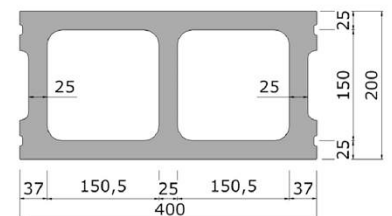

Fig 10 Hbl 7 hollow concrete block
(Bloque hormigon)

Sympafix construction plug CP-PLUS

Intended use
Geometry of stones

Annex B6

Installation instruction CP-PLUS

**in concrete or in
hollow core slabs**

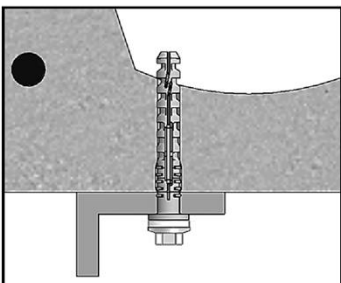
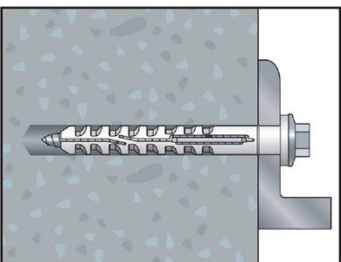
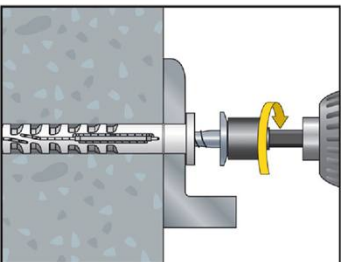
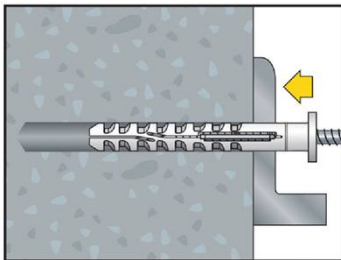
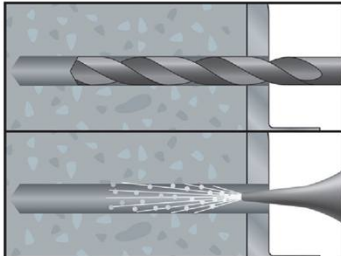

in masonry

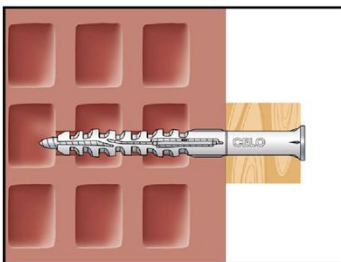
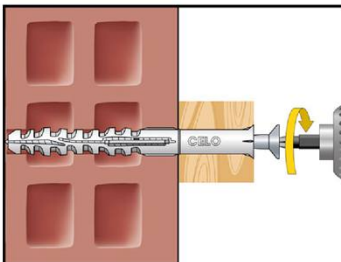
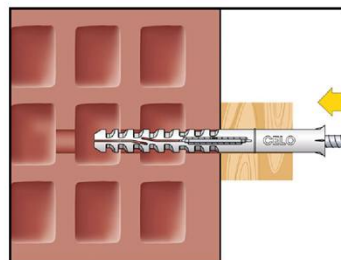
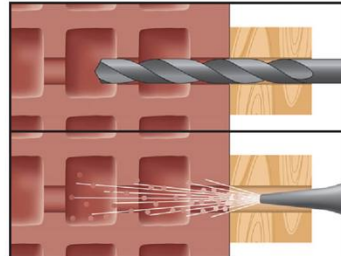

1. Drill the borehole and clean the hole.
Drilling method:
Concrete: hammer drill
Masonry: According Table C4, C5, C6

2. Hammer in the plug slightly through the fixture part till the plug is flush to this. Minimum setting depth (50 mm or 70 mm) must be observed.

3. Tighten the screw with screw driver till the screw touches the collar of the sleeve. The screw must fit tight on the surface of the fixture part.

4. Correctly installed plug with screw in concrete or in masonry.

4. Correctly installed plug with screw in hollow concrete core slab.

Sympafix construction plug CP-PLUS

Intended use
Installation instruction

Annex B7

Table C1.1: Characteristic bending resistance of the screws

Special screw Ø 6 mm for CP-PLUS 8		galvanised steel	stainless steel
Characteristic bending resistance	$M_{Rk,s}$ [Nm]	14,1	16,5
Partial safety factor	$\gamma_{Ms}^{1)}$	1,25	1,56
Special screw Ø 7 mm for CP-PLUS 10-60/ CP-PLUS 10		galvanised steel	stainless steel
Characteristic bending resistance	$M_{Rk,s}$ [Nm]	15,3	17,8
Partial safety factor	$\gamma_{Ms}^{1)}$	1,25	1,56
Special screw Ø 10 mm for CP-PLUS 14		galvanised steel	stainless steel
Characteristic bending resistance	$M_{Rk,s}$ [Nm]	36,7	42,9
Partial safety factor	$\gamma_{Ms}^{1)}$	1,25	1,56

¹⁾ in absence of other national regulations

Table C1.2: Characteristic resistance of the screws

Failure of expansion element (special screw)			
Special screw Ø 6 mm for CP-PLUS 8		galvanised steel	stainless steel
Characteristic tension resistance	$N_{Rk,s}$ [kN]	11,7	13,7
Partial safety factor	$\gamma_{Ms}^{1)}$	1,5	1,87
Characteristic shear resistance	$V_{Rk,s}$ [kN]	8,1	9,4
Partial safety factor	$\gamma_{Ms}^{1)}$	1,25	1,56
Special screw Ø 7 mm for CP-PLUS 10-60/ CP-PLUS 10		galvanised steel	stainless steel
Characteristic tension resistance	$N_{Rk,s}$ [kN]	17,0	19,8
Partial safety factor	$\gamma_{Ms}^{1)}$	1,5	1,87
Characteristic shear resistance	$V_{Rk,s}$ [kN]	8,5	9,9
Partial safety factor	$\gamma_{Ms}^{1)}$	1,25	1,56
Special screw Ø 10 mm for CP-PLUS 14		galvanised steel	stainless steel
Characteristic tension resistance	$N_{Rk,s}$ [kN]	30,5	35,5
Partial safety factor	$\gamma_{Ms}^{1)}$	1,5	1,87
Characteristic shear resistance	$V_{Rk,s}$ [kN]	15,2	17,8
Partial safety factor	$\gamma_{Ms}^{1)}$	1,25	1,56

¹⁾ in absence of other national regulations

Sympafix construction plug CP-PLUS

Performances

Characteristic resistance and characteristic bending resistance of the screws

Annex C1

Table C2.1: Characteristic resistance for use in cracked and uncracked concrete
(base material group "a")

Pull-out failure (plastic sleeve)			Concrete \geq C16/20		Concrete C12/15	
			$\vartheta =$ 24/40 °C	50/80 °C	24/40 °C	50/80 °C
CP-PLUS 8						
Characteristic resistance	$N_{Rk,p}$	[kN]	2,5	2,5	1,5	1,5
Partial safety factor	γ_{Mc}	¹⁾	1,8	1,8	1,8	1,8
CP-PLUS 10-60/ CP-PLUS 10 $h_{nom1} = 50$ mm						
Characteristic resistance	$N_{Rk,p}$	[kN]	2,5	2,0	1,5	1,5
Partial safety factor	γ_{Mc}	¹⁾	1,8	1,8	1,8	1,8
CP-PLUS 10 $h_{nom2} = 70$ mm						
Characteristic resistance	$N_{Rk,p}$	[kN]	4,0	3,0	2,5	2,0
Partial safety factor	γ_{Mc}	¹⁾	1,8	1,8	1,8	1,8
CP-PLUS 14						
Characteristic resistance	$N_{Rk,p}$	[kN]	4,5	3,0	3,0	2,0
Partial safety factor	γ_{Mc}	¹⁾	1,8	1,8	1,8	1,8

¹⁾ In absence of other national regulations

Table C2.2: Characteristic resistance for use in precast prestressed hollow core slabs
(base material group "a"), temperature range a (+24°/ +40°) and b (+50°/ +80°)

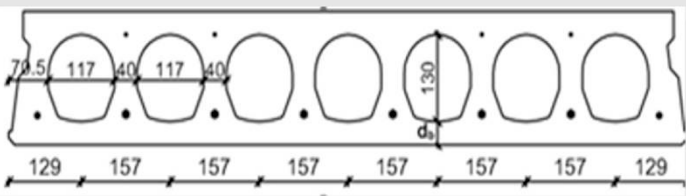
Pull-out failure (plastic sleeve)			Precast prestressed hollow core slabs	
			Producer: DW Systembau, D-29640 Schneverdingen or ANC TEC Leipzig	
CP-PLUS 8 Concrete \geq C45/55			Bottom flange thickness	
Characteristic resistance	$N_{Rk,p}$	[kN]	$d_b \geq 35$ mm	3,50
Partial safety factor	γ_{Mc}	¹⁾		1,8
CP-PLUS 10-60/ CP-PLUS 10 Concrete \geq C20/25 $h_{nom1} = 50$ mm				
Characteristic resistance	$N_{Rk,p}$	[kN]	$d_b \geq 35$ mm	2,00
Partial safety factor	γ_{Mc}	¹⁾		1,8
CP-PLUS 10 Concrete \geq C45/55 $h_{nom2} = 70$ mm				
Characteristic resistance	$N_{Rk,p}$	[kN]	$d_b \geq 35$ mm	1,20
Partial safety factor	γ_{Mc}	¹⁾		1,8

¹⁾ In absence of other national regulations

Sympafix construction plug CP-PLUS

Performances

Characteristic resistance for use in concrete and in precast hollow core slabs

Annex C2

Table C3.1: Displacements under tension and shear loading in concrete for both temperature ranges

	Tension load	Displacement		Shear load	Displacement	
		δ_{N0}	$\delta_{N\infty}$		δ_{V0}	$\delta_{V\infty}$
Concrete \geq C16/20	N ¹⁾	δ_{N0}	$\delta_{N\infty}$	V ¹⁾	δ_{V0}	$\delta_{V\infty}$
	[kN]	[mm]	[mm]	[kN]	[mm]	[mm]
CP-PLUS 8	0,99	0,25	0,05	2,47	0,80	1,20
CP-PLUS 10-60/ CP-PLUS 10 $h_{nom1} = 50$ mm	0,99	0,17	0,34	1,04	0,81	1,22
CP-PLUS 10 $h_{nom2} = 70$ mm	1,59	0,12	0,15	3,37	2,20	3,30
CP-PLUS 14	1,79	0,30	0,60	6,04	2,50	3,75

¹⁾ Intermediate values by linear interpolation

Table C 3.2: Values under fire exposure in concrete C20/25 to C50/60 in any load direction, no permanent centric tension load and without lever arm, fastening of facade systems

Anchor type	Fire resistance class	$F_{Rk,fi,90}$	$\gamma_{M,fi}$ ¹⁾
CP-PLUS 10	R 90	0,8 kN	1,0
CP-PLUS 14	R 90	0,8 kN	1,0

¹⁾ In absence of other national regulations.

Sympafix construction plug CP-PLUS

Performances
Displacements under tension and shear loading in concrete
Values under fire exposure

Annex C3

**Table C4: Characteristic resistance F_{Rk} [kN] in solid and hollow or perforated masonry
(base material group "b" + "c") for CP-PLUS 8**

CP-PLUS 8	Bulk density ρ	Compressive Strength f_b	Minimum DF or minimum size (L x W x H)	figure/ geometry	drill method H= hammer R= rotary	Characteristic resistance F_{Rk} ¹⁾
Base material	[kg/dm ³]	[N/mm ²]	[mm]			[kN]
						$\vartheta = 24/40$ °C $\vartheta = 50/80$ °C
Clay brick Mz EN 771-1:2011+A1:2015	$\geq 1,8$	≥ 20	NF (240*115*71)		H	1,5
Clay brick Mz EN 771-1:2011+A1:2015	$\geq 1,8$	≥ 10 < 20	NF (240*116*71)		H	0,9
Sand-lime solid brick KS EN 771-2:2011+A1:2015	$\geq 1,8$	≥ 20	2DF (240*115*113)		H	3,0
Sand-lime solid brick KS EN 771-2:2011+A1:2015	$\geq 1,8$	≥ 10 < 20	2DF (240*115*113)		H	2,0
Hollow clay brick HLz EN 771-1:2011+A1:2015	$\geq 1,0$	≥ 12	12 DF (373*240*249)	Annex B6 figure 2	R only	0,5
Hollow clay brick HLz 1 (Gero Tochana)	$\geq 0,8$	≥ 3	(285*125*90)	Annex B6 figure 8	R only	0,9
Hollow clay brick HLz 2 (Gero Tejala)	$\geq 1,0$	$\geq 5,9$	(280*135*90)	Annex B6 figure 9	R only	0,9
Hollow Sand-lime brick KSL EN 771-2:2011+A1:2015	$\geq 1,4$	≥ 17	3 DF (240*175*113)	Annex B6 figure 3	R	1,2
		≥ 12				0,75
Hollow light concrete block Hbl EN 771-3:2011+A1:2015	$\geq 0,8$	≥ 2	16 DF (500*240*248)	Annex B6 figure 7	R	0,3
Hollow light concrete block Hbl 7 (Bloque hormigon)	$\geq 1,0$	≥ 6	(400*200*200)	Annex B6 figure 10	R	0,9
Hollow concrete block Hbn EN 771-3:2011+A1:2015	$\geq 1,4$	≥ 25	12 DF (365*240*238)	Annex B6 figure 5	H	1,2
Partial safety factor ²⁾					γ_{Mm}	2,5

¹⁾ Characteristic resistance for tension, shear or combined tension and shear loading

²⁾ In absence of other national regulations

Sympafix construction plug CP-PLUS

Performances
CP-PLUS 8 – Characteristic resistance for use in masonry

Annex C4

**Table C5: Characteristic resistance F_{Rk} [kN] in solid and hollow or perforated masonry
(base material group "b" + "c") for CP-PLUS 10 and CP-PLUS 10-60**

CP-PLUS 10-60/ CP-PLUS 10	Bulk density ρ	Compressive strength f_b	Minimum DF or minimum size (L x W x H)	figure/ geometry	drill method H= hammer R= rotary	Characteristic resistance F_{Rk} ¹⁾ h_{nom1} = 50 mm		Characteristic resistance F_{Rk} ¹⁾ h_{nom2} = 70 mm	
						[kN]	[kN]	[kN]	[kN]
Base material	[kg/dm ³]	[N/mm ²]	[mm]			$\vartheta = 24/40$ °C	$\vartheta = 50/80$ °C	$\vartheta = 24/40$ °C	$\vartheta = 50/80$ °C
Clay brick Mz EN 771-1:2011+A1:2015	$\geq 1,8$	≥ 20	2DF (240*116*113)		H	3,0	2,5	3,0	2,5
Clay brick Mz EN 771-1:2011+A1:2015	$\geq 1,8$	≥ 10 < 20	2DF (240*116*113)		H	2,0	1,5	2,0	1,5
Sand-lime solid brick KS EN 771-2:2011+A1:2015	$\geq 1,8$	≥ 20	2DF (240*115*113)		H	4,0	3,5	3,0	2,5
Sand-lime solid brick KS EN 771-2:2011+A1:2015	$\geq 1,8$	≥ 10 < 20	2DF (240*115*113)		H	2,5	2,5	2,0	2,0
Hollow clay brick HLz EN 771-1:2011+A1:2015	$\geq 1,0$	≥ 12	2 DF (235*112*115)	Annex B6 figure 1	R only	3)	3)	0,75	0,6
Hollow clay brick HLz EN 771-1:2011+A1:2015	$\geq 1,0$	≥ 12	12 DF (373*240*249)	Annex B6 figure 2	R only	1,2	1,0	3)	3)
Hollow clay brick HLz 1 (Gero Tochana)	0,8	≥ 3	(285*125*90)	Annex B6 figure 8	R only	1,2	0,9	3)	3)
Hollow clay brick HLz 2 (Gero Tejala)	1,0	$\geq 5,9$	(280*135*90)	Annex B6 figure 9	R only	0,75	0,6	3)	3)
Hollow sand-lime brick KSL EN 771-2:2011+A1:2015	$\geq 1,4$	≥ 12	8 DF (250*240*237)	Annex B6 figure 4	R	1,5	1,2	0,9	0,6
Hollow concrete block Hbn EN 771-3:2011+A1:2015	$\geq 1,4$	≥ 25	12 DF (365*240*238)	Annex B6 figure 5	H	2,5	2,0	0,75	0,75
Hollow light concrete block Hbl 7 (Bloque hormigon)	$\geq 1,0$	≥ 6	(400*200*200)	Annex B6 figure 10	R	0,6 CP-PLUS 10-60	0,5 CP-PLUS 10-60	3)	3)
Hollow light concrete block Hbl 7 (Bloque hormigon)	$\geq 1,0$	≥ 6	(400*200*200)	Annex B6 figure 10	R	0,75 CP-PLUS 10	0,6 CP-PLUS 10	3)	3)
Hollow clay brick Brique Creuse C LD 3-0,7-500x200x200 EN 771-1:2011+A1:2015	$\geq 0,7$	≥ 3	(496*196*194)	Annex B6 figure 6	R only	3)	3)	0,3	0,3
Partial safety factor ²⁾					γ_{Mm}	2,5			

¹⁾ Characteristic resistance for tension, shear or combined tension and shear loading

²⁾ In absence of other national regulations

³⁾ No performance assessed

Sympafix construction plug CP-PLUS

Performances
CP-PLUS 10 – Characteristic resistance for use in masonry

Annex C5

**Table C6: Characteristic resistance F_{Rk} [kN] in solid and hollow or perforated masonry
(base material group "b" + "c") for CP-PLUS 14**

CP-PLUS 14	Bulk density ρ	Compressive strength f_b	Minimum DF or minimum size (L x W x H)	figure/geometry	drill method H= hammer R= rotary	Characteristic resistance F_{Rk} ¹⁾	
						$\vartheta = 24/40$ °C	$\vartheta = 50/80$ °C
Base material	[kg/dm ³]	[N/mm ²]	[mm]			[kN]	
Clay brick Mz EN 771-1:2011+A1:2015	$\geq 1,8$	≥ 20	NF (240*116*71)		H	4,5	3,0
Clay brick Mz EN 771-1:2011+A1:2015	$\geq 1,8$	≥ 10 < 20	NF (240*116*71)		H	3,0	2,0
Sand-lime solid brick KS EN 771-2:2011+A1:2015	$\geq 1,8$	≥ 20	8 DF (250*240*237)		H	5,0	4,5
Sand-lime solid brick KS EN 771-2:2011+A1:2015	$\geq 1,8$	≥ 10 < 20	8 DF (250*240*237)		H	3,5	3,0
Sand-lime solid brick KS EN 771-2:2011+A1:2015	$\geq 1,8$	≥ 20	2 DF (240*115*113)		H	4,5	4,0
Sand-lime solid brick KS EN 771-2:2011+A1:2015	$\geq 1,8$	≥ 10 < 20	2 DF (240*115*113)		H	3,0	2,5
Hollow clay brick HLz EN 771-1:2011+A1:2015	$\geq 1,0$	≥ 12	2 DF (235*115*113)	Annex B6 figure 1	R only	0,75	0,5
Hollow sand-lime brick KSL EN 771-2:2011+A1:2015	$\geq 1,4$	≥ 12	8 DF (250*240*237)	Annex B6 figure 4	R	1,2	0,75
Partial safety factor ²⁾					γ_{Mm}	2,5	

1) Characteristic resistance for tension, shear or combined tension and shear loading

2) In absence of other national regulations

Sympafix construction plug CP-PLUS

Performances
CP-PLUS 14 – Characteristic resistance for use in masonry

Annex C6

Table C7: Displacements under tension and shear loading in masonry for both temperature ranges

	Tension load			Shear load		
	N	Displacements		V	Displacements	
	[kN]	δ_{N0}	$\delta_{N\infty}$	[kN]	δ_{V0}	$\delta_{V\infty}$
		[mm]	[mm]		[mm]	[mm]
CP-PLUS 8	0,57	0,33	0,66	0,57	0,48	0,72
CP-PLUS 10-60/ CP-PLUS 10 $h_{nom1} = 50 \text{ mm}$	0,71	0,29	0,58	0,71	0,62	0,93
CP-PLUS 10 $h_{nom2} = 70 \text{ mm}$	0,86	0,20	0,40	0,86	0,71	1,07
CP-PLUS 14	1,43	0,20	0,40	1,43	1,19	1,79

Sympafix construction plug CP-PLUS

Performances
Displacements for use in masonry

Annex C7

Base material solid masonry: Autoclaved Aerated Concrete

Table C8.1: Brick Data

Description of brick			Autoclaved aerated concrete
Type of brick			unreinforced autoclaved aerated concrete
Bulk density	$\rho \geq$	[kg/dm ³]	0,35
European Standard			EN 771-4:2011+A1:2015
Minimum thickness of member CP-PLUS 8	$h_{\min} =$	[mm]	240
Minimum thickness of member CP-PLUS 10/14	$h_{\min} =$	[mm]	100

Installation parameters see Annex B2

Table C8.2: Characteristic resistance F_{Rk} [kN] in autoclaved aerated concrete (base material group "d")

Base material	mean compressive strength according to EN 771-4:2011 +A1:2015 $f_{cm,decl}$	Drill method	Characteristic resistance F_{Rk} ¹⁾	
	[N/mm ²]		$\vartheta = 24/40$ °C	$\vartheta = 50/80$ °C
CP-PLUS 8 $h_{nom} = 50$ mm				
Autoclaved aerated concrete	≥ 2	Rotary drilling	0,3	0,3
	$\geq 3,5$	Rotary drilling	1,2	0,9
	≥ 6	Rotary drilling	2,0	1,5
CP-PLUS 10 $h_{nom2} = 70$ mm				
Autoclaved aerated concrete	≥ 2	Rotary drilling	0,4	0,3
	≥ 4	Rotary drilling	1,2	0,9
	≥ 6	Rotary drilling	2,0	1,5
CP-PLUS 14 $h_{nom} = 70$ mm				
Autoclaved aerated concrete	≥ 2	Rotary drilling	0,3	0,3
	≥ 4	Rotary drilling	1,2	1,2
	≥ 6	Rotary drilling	2,0	2,0
Partial safety factor ²⁾		$\gamma_{M,AAC}$	2,0	

¹⁾ Characteristic resistance F_{Rk} for tension, shear or combined tension and shear loading

²⁾ In absence of other national regulations

Sympafix construction plug CP-PLUS

Performances

CP-PLUS 8/10/14 – Characteristic resistance for use in autoclaved aerated concrete

Annex C8

**Table C9: Displacements under tension and shear loading in autoclaved aerated concrete
for both temperature ranges**

Autoclaved aerated concrete with mean compressive strength according to EN 771-4:2011 +A1:2015	Tension load N [kN]	Displacements		Shear load V [kN]	Displacements	
		δ_{N0} [mm]	$\delta_{N\infty}$ [mm]		δ_{V0} [mm]	$\delta_{V\infty}$ [mm]
CP-PLUS 8 $h_{nom} = 50 \text{ mm}$						
$f_{cm,decl} \geq 2 \text{ N/mm}^2$	0,11	0,04	0,09	0,11	0,11	0,16
$f_{cm,decl} \geq 3,5 \text{ N/mm}^2$	0,43	0,05	0,10	0,43	0,33	0,50
$f_{cm,decl} \geq 6 \text{ N/mm}^2$	0,71	0,19	0,38	0,71	0,55	0,82
CP-PLUS 10 $h_{nom2} = 70 \text{ mm}$						
$f_{cm,decl} \geq 2 \text{ N/mm}^2$	0,14	0,10	0,20	0,14	0,30	0,40
$f_{cm,decl} \geq 4 \text{ N/mm}^2$	0,43	0,10	0,20	0,43	0,90	1,30
$f_{cm,decl} \geq 6 \text{ N/mm}^2$	0,71	0,10	0,20	0,71	1,40	2,10
CP-PLUS 14 $h_{nom} = 70 \text{ mm}$						
$f_{cm,decl} \geq 2 \text{ N/mm}^2$	0,11	0,10	0,20	0,11	0,20	0,30
$f_{cm,decl} \geq 4 \text{ N/mm}^2$	0,43	0,10	0,20	0,43	0,90	1,30
$f_{cm,decl} \geq 6 \text{ N/mm}^2$	0,71	0,10	0,20	0,71	1,40	2,10

Sympafix construction plug CP-PLUS

Performances
CP-PLUS 8/10/14 – Displacements for use in autoclaved aerated concrete under tension
and shear load

Annex C9